

Engineering Data



Series VRF



MDVO-V6252V2R1BE

MDVO-V6280V2R1BE

MDVO-V6335V2R1BE

MDVO-V6400V2R1BE

MDVO-V6450V2R1BE

MDVO-V6500V2R1BE

MDVO-V6560V2R1BE

MDVO-V6615V2R1BE

MDVO-V6670V2R1BE

MDVO-V6730V2R1BE

MDVO-V6785V2R1BE

MDVO-V6850V2R1BE

MDVO-V6900V2R1BE

CONTENTS

Part 1 General Information..... 3

Part 2 Outdoor Unit Engineering Data 18

Part 3 System Design and Installation..... 214

Part 1

General Information

1	Indoor and Outdoor Unit Capacities	4
2	External Appearance.....	6
3	Outdoor Unit Combinations.....	8
4	Nomenclature.....	9
5	Combination Ratio.....	12
6	Selection Procedure.....	13

1 Indoor and Outdoor Unit Capacities

1.1 Indoor Units

1.1.1 Standard indoor units

Table 1-1.1: Standard indoor unit abbreviation codes

Abbreviation code	Type
C1	One-way Cassette
C2	Two-way Cassette
C4C	Compact Four-way Cassette
C4	Four-way Cassette
D2	Medium Static Pressure Duct

Abbreviation code	Type
D3	High Static Pressure Duct
WM	Wall-mounted
CF	Ceiling & Floor
FS	Floor Standing

Table 1-1.2: Standard indoor unit capacity range

Capacity		Capacity index	C1	C2	C4C	C4	D2	D3	WM	CF	FS
kW	HP										
1.8	0.6	18	18	—	—	—	—	—	—	—	—
2.2	0.8	22	22	22	22	—	22	—	22	—	22
2.8	1	28	28	28	28	28	28	—	28	—	28
3.6	1.25	36	36	36	36	36	36	—	36	36	36
4.5	1.6	45	45	45	45	45	45	—	45	45	45
5.6	2	56	56	56	—	56	56	—	56	56	56
7.1	2.5	71	71	71	—	71	71	71	71	71	71
8.0	3	80	—	—	—	80	80	80	80	80	80
9.0	3.2	90	—	—	—	90	90	90	90	90	—
10.0	3.6	100	—	—	—	100	—	—	—	—	—
11.2	4	112	—	—	—	112	112	112	—	112	—
14.0	5	140	—	—	—	140	140	140	—	140	—
16.0	6	160	—	—	—	—	—	160	—	160	—
20.0	7	200	—	—	—	—	—	200	—	—	—
25.0	9	250	—	—	—	—	—	250	—	—	—
28.0	10	280	—	—	—	—	—	280	—	—	—
40.0	14	400	—	—	—	—	—	400	—	—	—
45.0	16	450	—	—	—	—	—	450	—	—	—
56.0	20	560	—	—	—	—	—	560	—	—	—

1.1.2 Fresh air processing unit

Table 1-1.3: Fresh air processing unit capacity range

Capacity	12.5kW	14kW
Capacity index	125	140

1.2 Heat recovery ventilator

Table 1-1.4: Heat recovery ventilator capacity range

Airflow rate	200m ³ /h	300m ³ /h	400m ³ /h	500m ³ /h	800m ³ /h	1000m ³ /h	1500m ³ /h	2000m ³ /h
--------------	----------------------	----------------------	----------------------	----------------------	----------------------	-----------------------	-----------------------	-----------------------

1.3 Outdoor Units
Table 1-1.5: Outdoor unit capacity range

Capacity	Model Name	Combination Type
8HP	MDVO-V6252V2R1BE	/
10HP	MDVO-V6280V2R1BE	/
12HP	MDVO-V6335V2R1BE	/
14HP	MDVO-V6400V2R1BE	/
16HP	MDVO-V6450V2R1BE	/
18HP	MDVO-V6500V2R1BE	/
20HP	MDVO-V6560V2R1BE	/
22HP	MDVO-V6615V2R1BE	/
24HP	MDVO-V6670V2R1BE	/
26HP	MDVO-V6730V2R1BE	/
28HP	MDVO-V6785V2R1BE	/
30HP	MDVO-V6850V2R1BE	/
32HP	MDVO-V6900V2R1BE	/
34HP	MDVO-V6950V2R1BE	12HP+22HP
36HP	MDVO-V61015V2R1BE	14HP+22HP
38HP	MDVO-V61065V2R1BE	16HP+22HP
40HP	MDVO-V61120V2R1BE	12HP+28HP
42HP	MDVO-V61175V2R1BE	20HP+22HP
44HP	MDVO-V61230V2R1BE	22HP+22HP
46HP	MDVO-V61285V2R1BE	22HP+24HP
48HP	MDVO-V61345V2R1BE	22HP+26HP
50HP	MDVO-V61400V2R1BE	22HP+28HP
52HP	MDVO-V61460V2R1BE	26HP+26HP
54HP	MDVO-V61515V2R1BE	26HP+28HP
56HP	MDVO-V61570V2R1BE	28HP+28HP
58HP	MDVO-V61635V2R1BE	28HP+30HP
60HP	MDVO-V61685V2R1BE	28HP+32HP
62HP	MDVO-V61750V2R1BE	30HP+32HP
64HP	MDVO-V61800V2R1BE	32HP+32HP
66HP	MDVO-V61850V2R1BE	12HP+22HP+32HP
68HP	MDVO-V61915V2R1BE	14HP+22HP+32HP
70HP	MDVO-V61965V2R1BE	16HP+22HP+32HP
72HP	MDVO-V62020V2R1BE	12HP+28HP+32HP
74HP	MDVO-V62075V2R1BE	20HP+22HP+32HP
76HP	MDVO-V62130V2R1BE	22HP+22HP+32HP
78HP	MDVO-V62185V2R1BE	22HP+24HP+32HP
80HP	MDVO-V62245V2R1BE	22HP+26HP+32HP
82HP	MDVO-V62300V2R1BE	22HP+28HP+32HP
84HP	MDVO-V62360V2R1BE	26HP+26HP+32HP
86HP	MDVO-V62415V2R1BE	26HP+28HP+32HP
88HP	MDVO-V62470V2R1BE	28HP+28HP+32HP
90HP	MDVO-V62535V2R1BE	28HP+30HP+32HP
92HP	MDVO-V62585V2R1BE	28HP+32HP+32HP
94HP	MDVO-V62650V2R1BE	30HP+32HP+32HP
96HP	MDVO-V62700V2R1BE	32HP+32HP+32HP

Notes:





- The combinations of units shown in the table are factory-recommended. Other combinations of units are also available.

2 External Appearance

2.1 Indoor Units

2.1.1 Standard indoor units

Table 1-2.1: Standard indoor unit appearance

One-way Cassette C1 	Two-way Cassette C2 
Compact Four-way Cassette C4C 	Four-way Cassette C4 
Medium Static Pressure Duct D2 	High Static Pressure Duct D3 
Wall-mounted WM 	Ceiling & Floor CF 
Floor Standing FS 	

2.1.2 Fresh air processing unit

Table 1-2.2: Fresh air processing unit appearance





Fresh Air Processing Unit OA 
--

2.2 Heat Recovery Ventilator













Table 1-2.3: Heat recovery ventilator appearance

Heat Recovery Ventilator 

2.3 Outdoor Units
2.3.1 Single units
Table 1-2.4: Single outdoor unit appearance

8/10/12HP (with single fan)	14/16HP (with single fan)	18/20/22HP (with dual fans)	24/26/28/30/32HP (with dual fans)
			

2.3.2 Combinations of units
Table 1-2.5: Combination outdoor unit appearance

34HP	36/38HP	40HP
		
42/44HP	46/48/50HP	52/54/56/58/60/62/64HP
		
66HP	68/70HP	72HP
		
74/76HP	78/80/82HP	84/86/88/90/92/94/96HP
		

3 Outdoor Unit Combinations

Table 1-3.1: Outdoor unit combinations

System capacity		Number of units	Modules ¹													Outdoor branch joint kit ²		
kW	HP		8	10	12	14	16	18	20	22	24	26	28	30	32			
25.2	8	1	•															
28.0	10	1		•														
33.5	12	1			•													
40.0	14	1				•												
45.0	16	1					•											
50.0	18	1						•										
56.0	20	1							•									
59.0	22	1								•								
67.0	24	1									•							
73.0	26	1										•						
75.5	28	1											•					
85.0	30	1												•				
85.0	32	1															•	
92.5	34	2			•						•							
99.0	36	2				•					•							
104.0	38	2					•				•							
109.0	40	2			•								•					
115.0	42	2						•			•							
118.0	44	2								••								
126.0	46	2								•	•							
132.0	48	2								•		•						
134.5	50	2								•			•					
146.0	52	2									••							
148.5	54	2									•	•						
151.0	56	2										••						
160.5	58	2										•		•				
160.5	60	2										•				•		
170.0	62	2												•		•		
170.0	64	2														••		
177.5	66	3			•						•						•	
184.0	68	3				•					•						•	
189.0	70	3					•				•						•	
194.0	72	3			•								•				•	
200.0	74	3						•			•						•	
203.0	76	3								••							•	
211.0	78	3								•	•						•	
217.0	80	3								•		•					•	
219.5	82	3								•			•				•	
231.0	84	3									••						•	
233.5	86	3									•	•					•	
236.0	88	3										••					•	
245.5	90	3										•	•				•	
245.5	92	3										•		•			••	
255.0	94	3												•			••	
255.0	96	3															•••	

Notes:

1. The combinations of units shown in the table are factory-recommended. Other combinations of units are also available.
2. For systems with two or more outdoor units, outdoor branch joints (sold separately) are required.

4 Nomenclature

4.1 Indoor Units

4.1.1 Standard indoor units

MDV **I** **-** **22** **C1** **V** **R1** **D**
 ① ② ③ ④ ⑤ ⑥ ⑦

Legend		
No.	Code	Remarks
1	MDV	Midea MDV brand
2	I	VRF indoor unit
3	22	Capacity index (the capacity in kW multiplied by 10)
4	C1	Indoor unit type C1: One-way Cassette C2: Two-way Cassette C4C: Compact Four-way Cassette C4: Four-way Cassette D2: Medium Static Pressure Duct D3: High Static Pressure Duct WM: Wall-mounted CF: Ceiling & Floor FS: Floor Standing
5	V	Series category (V: DC series)
6	R1	Refrigerant type (N1: R410A)
7	D	Power supply D: 1 phase, 220-240V, 50/60Hz

4.1.2 Fresh air processing unit

MDV **I** **-** **280** **OA** **V** **R1** **D**
 ① ② ③ ④ ⑤ ⑥ ⑦

Legend		
No.	Code	Remarks
1	MDV	Midea MDV brand
2	I	VRF indoor unit
3	280	Capacity index (the capacity in kW multiplied by 10)
4	OA	Indoor unit type OA: Fresh Air Processing Unit
5	V	Series category (V: DC series)
6	R1	Refrigerant type (N1: R410A)
7	D	Power supply D: 1 phase, 220-240V, 50/60Hz

4.1.3 Heat recovery ventilator

AC Series

$$\text{HRV} = 200$$

① ②

Legend		
No.	Code	Remarks
1	HRV	Heat recovery ventilator
2	200	Airflow in m ³ /h

DC Series

$$\text{HRV} = \text{D} 200$$

① ② ③

Legend		
No.	Code	Remarks
1	HRV	Heat recovery ventilator
2	D	Series category (D: DC series)
3	200	Airflow in m ³ /h

4.2 Outdoor Units

MDV **O** **V6** **-** **252** **V2** **R1** **B** **E**
 ① ② ③ ④ ⑤ ⑥ ⑦ ⑧

Legend		
No.	Code	Remarks
1	MDV	Midea MDV brand
2	O	Unit category (O: VRF outdoor unit)
3	V6	The 6 th generation VRF
4	252	Capacity index (the capacity in kW multiplied by 10)
5	V2	Type (V2: All DC inverter)
6	R1	Refrigerant type (R1: R410A)
7	B	Power supply (G: 3 phase, 380-415V, 50Hz)
8	E	Europe version

5 Combination Ratio

Combination ratio = $\frac{\text{Sum of capacity indexes of the indoor units}}{\text{Capacity index of the outdoor units}}$

Table 1-5.1: Indoor and outdoor unit combination ratio limitations

Type	Minimum combination ratio	Maximum combination ratio		
		Standard indoor units only	Fresh air processing units only	Fresh air processing units and standard indoor units together
V6 Series outdoor units	50%	130%	100%	100% ¹

- Notes:
- When fresh air processing units are installed together with standard indoor units, the total capacity of the fresh air processing units must not exceed 30% of the total capacity of the outdoor units and the total combination ratio must not exceed 100%.

Table 1-5.2: Combinations of indoor and outdoor units

Outdoor unit capacity			Sum of capacity indexes of connected indoor units (standard indoor units only)	Sum of capacity indexes of connected indoor units (fresh air processing units and standard indoor units together)	Maximum number of connected indoor units
kW	HP	Capacity index			
25.2	8	252	126 to 327.6	126 to 252	13
28.0	10	280	140 to 364	140 to 280	16
33.5	12	335	167.5 to 435.5	167.5 to 335	20
40.0	14	400	200 to 520	200 to 400	23
45.0	16	450	225 to 585	225 to 450	26
50.0	18	500	250 to 650	250 to 500	29
56.0	20	560	280 to 728	280 to 560	33
59.0	22	590	295 to 799.5	307.5 to 590	36
67.0	24	670	335 to 871	335 to 670	39
73.0	26	730	365 to 949	365 to 730	43
75.5	28	755	392.5 to 1020.5	392.5 to 755	46
85.0	30	850	425 to 1105	425 to 850	50
85.0	32	850	425 to 1105	425 to 850	53
92.5	34	925	462.5 to 1202.5	462.5 to 925	56
99.0	36	990	495 to 1287	495 to 990	59
104.0	38	1040	520 to 1352	520 to 1040	63
109.0	40	1090	545 to 1417	545 to 1090	64
115.0	42	1150	575 to 1495	575 to 1150	
118.0	44	1180	590 to 1534	590 to 1180	
126.0	46	1260	630 to 1638	630 to 1260	
132.0	48	1320	660 to 1716	660 to 1320	
134.5	50	1345	672.5 to 1748.5	672.5 to 1345	
146.0	52	1460	730 to 1898	730 to 1460	
148.5	54	1485	742.5 to 1930.5	742.5 to 1485	
151.0	56	1510	755 to 1963	755 to 1510	
160.5	58	1605	802.5 to 2086.5	802.5 to 1605	
160.5	60	1605	802.5 to 2086.5	802.5 to 1605	
170.0	62	1700	850 to 2210	850 to 1700	
170.0	64	1700	850 to 2210	850 to 1700	
177.5	66	1775	887.5 to 2307.5	987.5 to 1775	
184.0	68	1840	920 to 2392	920 to 1840	
189.0	70	1890	945 to 2457	945 to 1890	
194.0	72	1940	970 to 2522	970 to 1940	
200.0	74	2000	1000 to 2600	1000 to 2000	
203.0	76	2030	1015 to 2639	1015 to 2030	
211.0	78	2110	1055 to 2743	1055 to 2110	
217.0	80	2170	1085 to 2821	1085 to 2170	
219.5	82	2195	1097.5 to 2853.5	1097.5 to 2195	
231.0	84	2310	1155 to 3003	1155 to 2310	
233.5	86	2335	1167.5 to 3035.5	1167.5 to 2335	
236.0	88	2360	1180 to 3068	1180 to 2360	
245.5	90	2455	1227.5 to 3191.5	1227.5 to 2455	
245.5	92	2455	1227.5 to 3191.5	1227.5 to 2455	
255.0	94	2550	1275 to 3315	1275 to 2550	
255.0	96	2550	1275 to 3315	1275 to 2550	

6 Selection Procedure

6.1 Procedure

Step 1: Establish design conditions

Design temperature and humidity (indoor and outdoor)
 Required heat load of each room
 System peak load
 Piping length, level differences
 Indoor unit specifications (type and quantity)

Step 2: Select indoor units

Decide indoor unit safety factor

Select indoor unit models ensuring that:
 $\text{Indoor unit capacity corrected for indoor air temperature WB}^1 \geq \text{Required heat load} \times \text{Indoor unit safety factor}$

Step 3: Select outdoor units

Determine required total heat load on outdoor units

Use the sum of the peak load of each room Use the system peak load

Provisionally select outdoor unit capacity based on combination ratio limitations

Confirm that the number of indoor units connected to the outdoor units is within limitation

Correct cooling and heating capacities of the outdoor units for the following items:
 Outdoor air temperature / Indoor air temperature WB / Combination ratio / Piping length, level difference
 / Piping heat loss / Frost accumulation (for heating capacity only)

Is corrected outdoor unit capacity \geq Required total heat load on outdoor units?

No

Yes

VRF system selection is complete

Notes:

1. If the indoor design temperature falls between two temperatures listed in the indoor unit's capacity table, calculate the corrected capacity by interpolation. If the indoor unit selection is to be based on total heat load and sensible heat load, select indoor units which satisfy not only the total heat load requirements of each room but also the sensible heat load requirements of each room. As with total heat capacity, the sensible heat capacity of indoor units should be corrected for indoor temperature, interpolating where necessary. For the indoor unit capacity tables, refer to the indoor unit technical manuals.

6.2 Example

The following is a selection example based on total heat load for cooling.

Figure 1-6.1: Room plan

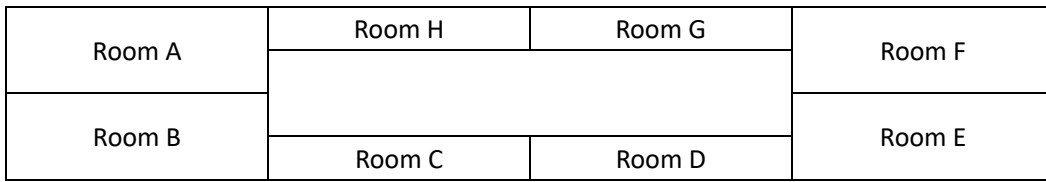

Step 1: Establish design conditions

- Indoor air temperature 25.8°C DB, 18°C WB; outdoor air temperature 33°C DB.
- Determine peak load of each room and system peak load. As shown in Table 1-6.1, the system peak load is 50.7kW.

Table 1-6.1: Required heat load of each room (kW)

Time	Room A	Room B	Room C	Room D	Room E	Room F	Room G	Room H	Total
9:00	4.8	4.8	3.0	3.0	9.1	9.0	2.9	2.9	39.5
12:00	6.6	7.1	5.1	5.1	7.4	6.8	4.0	4.0	46.1
14:00	9.0	9.4	4.9	4.9	7.3	6.8	4.2	4.2	50.7
16:00	10.6	10.7	3.9	3.9	6.3	6.2	3.8	3.8	49.2

- The maximum piping lengths and level differences in this example are as given in Figure 1-6.2.

Figure 1-6.2: System diagram

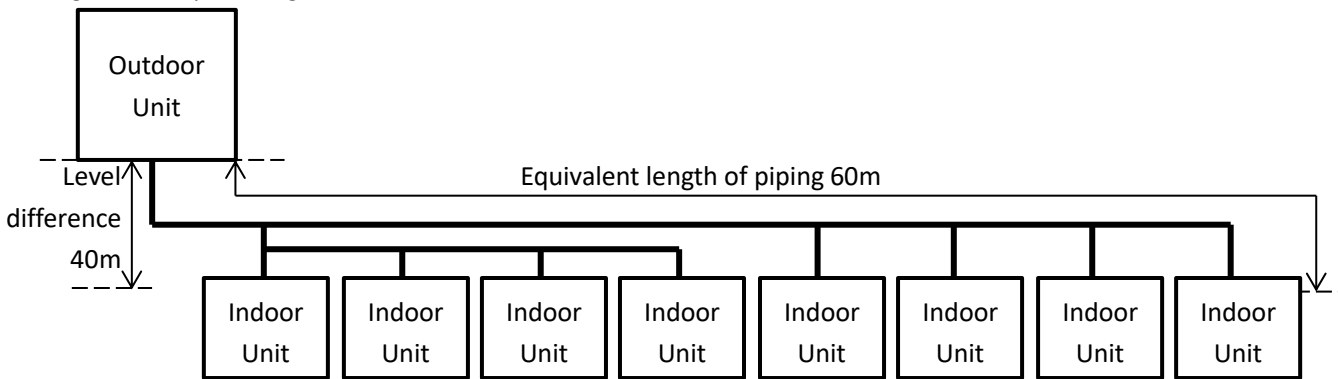

- Indoor unit type for all rooms: Medium Static Pressure Duct (T2).

Step 2: Select indoor units

- In this example, a safety factor is not used (i.e. the safety factor is 1).
- Select indoor unit models using the medium static pressure duct cooling capacity table. Each indoor unit's corrected capacity needs to be greater than or equal to the peak load of the relevant room. The selected indoor units are shown in Table 1-6.3.

Table 1-6.2: Extract from medium static pressure duct (D2) cooling capacity table

Model	Capacity index	Indoor air temperature													
		14°C WB		16°C WB		18°C WB		19°C WB		20°C WB		22°C WB		24°C WB	
		20°C DB		23°C DB		26°C DB		27°C DB		28°C DB		30°C DB		32°C DB	
		TC	SC	TC	SC	TC	SC	TC	SC	TC	SC	TC	SC	TC	SC
D2	22	1.5	1.4	1.8	1.5	2.1	1.6	2.2	1.6	2.3	1.7	2.4	1.5	2.4	1.5
	28	1.9	1.7	2.3	1.9	2.6	2.1	2.8	2.1	3.0	2.1	3.1	2.0	3.1	1.9
	36	2.5	2.1	2.9	2.3	3.4	2.5	3.6	2.6	3.8	2.7	4.2	2.8	3.9	2.3
	45	3.1	2.6	3.7	2.8	4.2	3.1	4.5	3.2	4.8	3.2	4.9	3.1	5.1	2.9
	56	3.9	3.0	4.6	3.3	5.3	3.6	5.6	3.7	5.9	3.8	6.2	3.7	6.2	3.4
	71	4.9	3.9	5.8	4.3	6.7	4.7	7.1	4.9	7.5	4.8	7.8	4.6	7.8	4.3
	80	5.5	4.4	6.6	4.9	7.5	5.3	8.0	5.5	8.4	5.5	8.8	5.2	8.8	4.8
	90	6.2	5.3	7.3	5.8	8.4	6.3	9.0	6.4	9.6	6.5	9.9	6.1	9.9	5.7
	112	7.7	6.4	9.1	7.1	10.5	7.7	11.2	7.8	11.9	8.1	12.5	7.8	12.5	7.4
	140	9.7	7.8	11.3	8.6	13.2	9.6	14.0	9.8	14.8	9.8	15.7	9.7	15.4	8.8

Abbreviations:

TC: Total capacity (kW); SC: Sensible capacity (kW)

Table 1-6.3: Selected indoor units

	Room A	Room B	Room C	Room D
Peak heat load (kW)	10.6	10.7	5.1	5.1
Selected indoor unit	MDVI-140D2VR1E	MDVI-140D2VR1E	MDVI-56D2VR1E	MDVI-56D2VR1E
Corrected TC (kW)	13.2	13.2	5.3	5.3
	Room E	Room F	Room G	Room H
Peak heat load (kW)	9.1	9.0	4.2	4.2
Selected indoor unit	MDVI-112D2VR1E	MDVI-112D2VR1E	MDVI-45D2VR1E	MDVI-45D2VR1E
Corrected TC (kW)	10.5	10.5	4.2	4.2

Step 3: Select outdoor units

- Determine the required total heat load from the indoor units to the outdoor units based on either the sum of the peak loads of each room or the system peak load. In this example, it is determined based on the system peak load. Therefore, the required heat load is 50.7kW.
- Provisionally select outdoor units using the sum of the capacity indexes (CIs) of the selected indoor units (as shown in Table 1-6.4), ensuring that the combination ratio is between 50% and 130%. Refer to Table 1-6.5. As the sum of CIs of the indoor units is 706, outdoor units from 20HP to 50HP are potentially suitable. Start from the smallest, which is the 20HP unit.

Table 1-6.4: Sum of indoor unit capacity indexes

Model	Capacity Index	No. of units
MDVI-140D2VR1E	140	2
MDVI-112D2VR1E	112	2
MDVI-56D2VR1E	56	2
MDVI-45D2VR1E	45	2

Sum of CIs	706
-------------------	------------

Table 1-6.5: Extract from Table 1-5.2 Combinations of Indoor and outdoor units

Outdoor unit capacity			Sum of capacity indexes of connected indoor units (standard indoor units only)	Maximum number of connected indoor units
kW	HP	Capacity index		
50.0	18	500	250 to 650	29
56.0	20	560	280 to 728	33
59.0	22	615	295 to 799.5	36
67.0	24	670	335 to 871	39
73.0	26	730	365 to 949	43
75.5	28	785	392.5 to 1020.5	46
85.0	30	850	425 to 1105	50
85.0	32	900	425 to 1105	53
92.5	34	950	462.5 to 1202.5	56
99.0	36	1015	495 to 1287	59
104.0	38	1065	520 to 1352	63
109.0	40	1120	545 to 1417	64
115.0	42	1175	575 to 1495	
118.0	44	1230	590 to 1534	
126.0	46	1285	630 to 1638	
132.0	48	1345	660 to 1716	
134.5	50	1400	672.5 to 1748.5	
146.0	52	1460	730 to 1898	

- The number of connected indoor units is 8 and the maximum number of connected indoor units on the 20HP outdoor unit is 33, so the number of connected indoor units is within the limitation.
- Calculate the corrected capacity of the outdoor units:
 - a) The sum of the indoor unit CIs is 706 and the CI of the 20HP outdoor unit (MDVO-V6560V2R1BE) is 560, so the combination ratio is $706 / 560 = 126\%$.
 - b) Using the outdoor units' cooling capacity table, interpolate to obtain the capacity ("B") corrected for outdoor air temperature, indoor air temperature, and combination ratio. Refer to Tables 1-6.6 and 1-6.7.

Table 1-6.6: Extract from Table 2-8.7 MDVO-V6560V2R1BE cooling capacity

CR	Outdoor air temp. (°C DB)	Indoor air temp. (°C DB / °C WB)	
		25.8 / 18.0	
		TC	PI
		kW	kW
130%	31	60.0	27.95
	33	59.2	28.99
	35	58.2	30.07
120%	31	59.0	27.79
	33	58.2	28.83
	35	57.2	29.86

Table 1-6.7: Cooling capacity calculated by interpolation

CR	Outdoor air temp. (°C DB)	Indoor air temp. (°C DB / °C WB)	
		25.8 / 18.0	
		TC	PI
		kW	kW
130%	33	59.2	28.99
		B = 58.8¹	
120%	33	58.2	28.83

Notes:

1. $58.2 + (59.2 - 58.2) \times (126 - 120) / (130 - 120) = 58.8$.

c) Find the correction factor for piping length and level difference ("K1")

Figure 1-6.3: V6 rate of change in cooling capacity

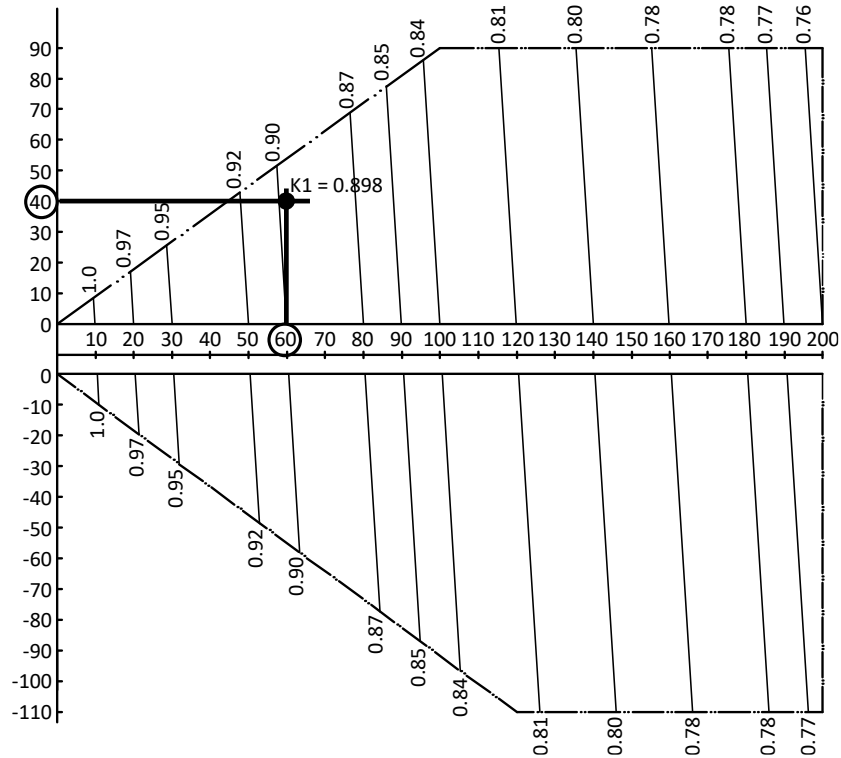

Notes:

1. The horizontal axis shows equivalent length of piping between farthest indoor unit and first outdoor branch joint; the vertical axis shows the largest level difference between indoor unit and outdoor unit. For level differences, positive values indicate that the outdoor unit is above the indoor unit, negative values indicate that the outdoor unit is below the indoor unit.

d) Calculate the corrected capacity of MDVO-V6560V2R1BE ("C") by using K1:

$$C = B \times K1 = 58.8 \times 0.898 = 52.8\text{kW}$$

- The corrected capacity 52.8kW is larger than required total heat load 50.7kW, so selection is complete. (In the event that the corrected capacity is lower than the required total heat load, Step 3 should be repeated from the point where the outdoor unit capacity is provisionally selected.)

Part 2

Outdoor Unit Engineering Data

1	Specifications	19
2	Dimensions.....	30
3	Installation Space Requirements.....	40
4	Piping Diagrams.....	41
5	Wiring Diagrams	47
6	Electrical Characteristics	49
7	Functional Components and Safety Devices.....	51
8	Capacity Tables	52
9	Operating Limits	210
10	Sound Levels.....	211
11	Accessories.....	213

1 Specifications

8-14HP

Table 2-1.1: 8-14HP specifications

HP			8	10	12	14
Model name			MDVO-V6450V2R1BE	MDVO-V6500V2R1BE	MDVO-V6560V2R1BE	MDVO-V6615V2R1BE
Power supply		V/Ph/Hz	380-415/3/50			
Cooling ¹	Capacity	kW	25.20	28.00	33.50	40.00
	Power input	kW	8.37	10.57	13.55	15.21
	EER		3.01	2.65	2.47	2.63
Heating ² (rated)	Capacity	kW	25.20	28.00	33.50	40.00
	Power input	kW	6.32	7.30	9.68	11.20
	COP		3.99	3.84	3.46	3.57
Heating ² (max)	Capacity	kW	27.00	31.50	37.50	45.00
	Power input	kW	7.07	8.75	11.61	13.52
	COP		3.82	3.60	3.23	3.33
SEER			6.86	6.50	6.07	6.37
η _{s,c}		%	271.6	257.1	239.7	252.0
SCOP			4.06	4.14	4.26	3.85
η _{s,h}		%	159.2	162.7	167.4	150.8
Connected indoor unit	Total capacity		50-130% of outdoor unit capacity			
	Maximum quantity		13	16	20	23
Compressor	Type		DC inverter			
	Quantity		1			
	Oil type		FV68H			
	Start-up method		Soft start			
Fan	Type		Propeller			
	Motor type		DC			
	Quantity		1			
	Motor output	kW	0.56	0.56	0.56	0.92
	Static pressure	Pa	0-20 (default); 20-60 (customized)			
	Airflow rate	m ³ /h	11000	11000	11000	13000
	Drive type		Direct			
Refrigerant	Type		R410A			
	Factory charge	kg	11	11	11	13
Pipe connections ³	Liquid pipe	mm	Φ12.7		Φ15.9	Φ15.9
	Gas pipe	mm	Φ25.4		Φ28.6	Φ31.8
Sound pressure level ⁴		dB(A)	58	58	60	62
Sound power level		dB(A)	83	84	85	86
Net dimensions (W×H×D)		mm	990×1635×790			1340×1635×850
Packed dimensions (W×H×D)		mm	1090×1805×860			1405×1805×910
Net weight		kg	227			277
Gross weight		kg	242			304
Ambient temp. operation range	Cooling	°C	-5 ~ 48			
	Heating	°C	-25 ~ 24			

Notes:

- Indoor air temperature 27°C DB, 19°C WB; outdoor air temperature 35°C DB; equivalent refrigerant piping length 7.5m with zero level difference.
- Indoor air temperature 20°C DB; outdoor air temperature 7°C DB, 6°C WB; equivalent refrigerant piping length 7.5m with zero level difference.
- Diameters given are those of the unit's stop valve.
- Sound pressure level is measured at a position 1m in front of the unit and 1.3m above the floor in a semi-anechoic chamber.

16-22HP

Table 2-1.2: 16-22HP specifications

HP			16	18	20	22
Model name			MDVO-V6450V2R1BE	MDVO-V6500V2R1BE	MDVO-V6560V2R1BE	MDVO-V6615V2R1BE
Power supply		V/Ph/Hz	380-415/3/50			
Cooling ¹	Capacity	kW	45.00	50.00	56.00	59.00
	Power input	kW	20.74	21.69	29.63	34.58
	EER		2.17	2.31	1.89	1.71
Heating ² (rated)	Capacity	kW	45.00	50.00	56.00	59.00
	Power input	kW	13.65	13.15	15.06	18.44
	COP		3.30	3.80	3.72	3.20
Heating ² (max)	Capacity	kW	50.00	56.00	63.00	66.20
	Power input	kW	16.42	15.87	18.09	21.86
	COP		3.05	3.53	3.48	3.03
SEER			5.64	5.93	5.38	5.10
η _{s,c}		%	222.8	234.3	212.3	201.0
SCOP			4.31	4.10	4.00	4.40
η _{s,h}		%	160.9	157.0	173.2	182.9
Connected indoor unit	Total capacity		50-130% of outdoor unit capacity			
	Maximum quantity		26	29	33	36
Compressor	Type		DC inverter			
	Quantity		1	2		
	Oil type		FV68H			
	Start-up method		Soft start			
Fan	Type		Propeller			
	Motor type		DC			
	Quantity		1	2		
	Motor output	kW	0.92	0.56×2	0.56×2	0.56×2
	Static pressure	Pa	0-20 (default); 20-60 (customized)			
	Airflow rate	m ³ /h	13000	17000	17000	17000
	Drive type		Direct			
Refrigerant	Type		R410A			
	Factory charge	kg	13	17	17	17
Pipe connections ³	Liquid pipe	mm	Φ15.9			
	Gas pipe	mm	Φ31.8			
Sound pressure level ⁴		dB(A)	65	65	66	66
Sound power level		dB(A)	86	88	89	89
Net dimensions (W×H×D)		mm	1340×1635×850	1340×1635×825		
Packed dimensions (W×H×D)		mm	1405×1805×910			
Net weight		kg	277	348		
Gross weight		kg	304	368		
Ambient temp. operation range	Cooling	°C	-5 ~ 48			
	Heating	°C	-25 ~ 24			

Notes:

- Indoor air temperature 27°C DB, 19°C WB; outdoor air temperature 35°C DB; equivalent refrigerant piping length 7.5m with zero level difference.
- Indoor air temperature 20°C DB; outdoor air temperature 7°C DB, 6°C WB; equivalent refrigerant piping length 7.5m with zero level difference.
- Diameters given are those of the unit's stop valve.
- Sound pressure level is measured at a position 1m in front of the unit and 1.3m above the floor in a semi-anechoic chamber.

24-32HP

Table 2-1.3: 24-32HP specifications

HP			24	26	28	30	32
Model name			MDVO-V6670V2R1BE	MDVO-V6730V2R1BE	MDVO-V6785V2R1BE	MDVO-V6850V2R1BE	MDVO-V6900V2R1BE
Power supply		V/Ph/Hz	380-415/3/50				
Cooling ¹	Capacity	kW	67.00	73.00	75.50	85.00	85.00
	Power input	kW	31.85	34.28	37.24	44.88	44.88
	EER			2.10	2.13	2.03	1.89
Heating ² (rated)	Capacity	kW	67.00	73.00	75.50	85.00	90.00
	Power input	kW	17.29	21.08	23.33	22.77	25.42
	COP			3.88	3.46	3.24	3.73
Heating ² (max)	Capacity	kW	75.00	81.50	84.20	95.00	100.00
	Power input	kW	20.94	25.23	28.56	27.53	30.33
	COP			3.58	3.23	2.95	3.45
SEER			5.68	5.83	5.43	5.15	5.15
η _{s,c}		%	224.3	230.3	214.4	202.9	202.9
COP			4.45	4.22	4.59	4.12	4.12
η _{s,h}		%	174.8	165.9	180.5	161.8	161.8
Connected indoor unit	Total capacity		50-130% of outdoor unit capacity				
	Maximum quantity		39	43	46	50	53
Compressor	Type		DC inverter				
	Quantity		2				
	Oil type		FV68H				
	Start-up method		Soft start				
Fan	Type		Propeller				
	Motor type		DC				
	Quantity		2				
	Motor output	kW	0.92×2	0.92×2	0.92×2	0.92×2	0.92×2
	Static pressure	Pa	0-20 (default); 20-60 (customized)				
	Airflow rate	m ³ /h	25000	25000	25000	24000	24000
	Drive type		Direct				
Refrigerant	Type		R410A				
	Factory charge	kg	22	22	22	25	25
Pipe connections P3	Liquid pipe	mm	Φ19.1	Φ22.2			Φ22.2
	Gas pipe	mm	Φ31.8	Φ31.8			Φ38.1
Sound pressure level ⁴		dB(A)	67	68			
Sound power level		dB(A)	92	93			
Net dimensions (W×H×D)		mm	1730 × 1830 × 850				
Packed dimensions (W×H×D)		mm	1800×2000×910				
Net weight		kg	430			475	
Gross weight		kg	453			507	
Ambient temp. operation range	Cooling	PoPC	-5 ~ 48				
	Heating	PoPC	-25 ~ 24				

Notes:

- Indoor air temperature 27°C DB, 19°C WB; outdoor air temperature 35°C DB; equivalent refrigerant piping length 7.5m with zero level difference.
- Indoor air temperature 20°C DB; outdoor air temperature 7°C DB, 6°C WB; equivalent refrigerant piping length 7.5m with zero level difference.
- Diameters given are those of the unit's stop valve.
- Sound pressure level is measured at a position 1m in front of the unit and 1.3m above the floor in a semi-anechoic chamber.

34-40HP

Table 2-1.4: 34-40HP specifications

HP			34	36	38	40
Model name (Combination unit)			MDVO-V6950V2R1BE	MDVO-V61015V2R1BE	MDVO-V61065V2R1BE	MDVO-V61120V2R1BE
Combination type			12HP+22HP	14HP+22HP	16HP+22HP	12HP+28HP
Power supply		V/Ph/Hz	380-415/3/50			
Cooling ¹	Capacity	kW	92.50	99.00	104.00	109.00
	Power input	kW	48.13	49.79	55.32	50.79
	EER		1.92	1.99	1.88	2.15
Heating ² (rated)	Capacity	kW	92.50	99.00	104.00	109.00
	Power input	kW	28.12	29.64	32.09	33.01
	COP		3.29	3.34	3.24	3.30
Heating ² (max)	Capacity	kW	103.70	111.20	116.20	121.70
	Power input	kW	33.47	35.38	38.28	40.18
	COP		3.10	3.14	3.04	3.03
SEER			5.40	5.53	5.31	5.61
η _{s,c}		%	213.0	218.4	209.6	221.4
COP			4.50	4.29	4.39	4.48
η _{s,h}		%	176.9	168.6	172.8	176.2
Connected indoor unit	Total capacity		50-130% of outdoor unit capacity			
	Maximum quantity		56	59	63	64
Compressor	Type		DC inverter			
	Quantity		3			
	Oil type		FV68H			
	Start-up method		Soft start			
Fan	Type		Propeller			
	Motor type		DC			
	Quantity		3			
	Motor output	kW	0.56×3	0.92+0.56×2	0.92+0.56×2	0.56+0.92×2
	Static pressure	Pa	0-20 (default); 20-60 (customized)			
	Airflow rate	m ³ /h	28000	30000	30000	36000
	Drive type		Direct			
Refrigerant	Type		R410A			
	Factory charge	kg	11+17	13+17	13+17	11+22
Pipe connections ³	Liquid pipe	mm	Φ19.1		Φ19.1	
	Gas pipe	mm	Φ31.8		Φ38.1	
Sound pressure level ⁴		dB(A)	69			
Sound power level		dB(A)	91			
Net dimensions (W×H×D)		mm	(990×1635×790)+ (1340×1635×825)	(1340×1635×850)+ (1340×1635×825)	(990×1635×790)+ (1730×1830×850)	
Packed dimensions (W×H×D)		mm	(1090×1805×860)+ (1405×1805×910)	(1405×1805×910)×2		(1090×1805×860)+ (1800×2000×910)
Net weight		kg	227+348	277+348		227+430
Gross weight		kg	242+368	304+368		242+453
Ambient temp. operation range	Cooling	°C	-5 ~ 48			
	Heating	°C	-25 ~ 24			

Notes:

- Indoor air temperature 27°C DB, 19°C WB; outdoor air temperature 35°C DB; equivalent refrigerant piping length 7.5m with zero level difference.
- Indoor air temperature 20°C DB; outdoor air temperature 7°C DB, 6°C WB; equivalent refrigerant piping length 7.5m with zero level difference.
- Diameters given are those for the pipe connecting the outdoor unit combination to the first indoor branch joint for systems with total equivalent liquid piping lengths of less than 90m. For systems with total equivalent liquid piping lengths of 90m or longer, please refer to Part 3 "System Design and Installation" for connection piping diameters..
- Sound pressure level is measured at a position 1m in front of the unit and 1.3m above the floor in a semi-anechoic chamber.

42-48HP

Table 2-1.5: 42-48HP specifications

HP			42	44	46	48
Model name (Combination unit)			MDVO-V61175V2R1BE	MDVO-V61230V2R1BE	MDVO-V61285V2R1BE	MDVO-V61345V2R1BE
Combination type			20HP+22HP	22HP+22HP	22HP+24HP	22HP+26HP
Power supply		V/Ph/Hz	380-415/3/50			
Cooling ¹	Capacity	kW	115.00	118.00	126.00	132.00
	Power input	kW	64.21	69.16	66.43	68.86
	EER			1.79	1.71	1.90
Heating ² (rated)	Capacity	kW	115.00	118.00	126.00	132.00
	Power input	kW	33.50	36.88	35.73	39.52
	COP			3.43	3.20	3.53
Heating ² (max)	Capacity	kW	129.2	132.4	141.2	147.7
	Power input	kW	39.95	43.72	42.80	47.09
	COP			3.23	3.03	3.30
SEER			5.23	5.10	5.39	5.47
η _{s,c}		%	206.2	201.0	212.4	215.8
COP			4.53	4.65	4.54	4.40
η _{s,h}		%	178.2	182.9	178.5	172.9
Connected indoor unit	Total capacity		50-130% of outdoor unit capacity			
	Maximum quantity		64			
Compressor	Type		DC inverter			
	Quantity		4			
	Oil type		FV68H			
	Start-up method		Soft start			
Fan	Type		Propeller			
	Motor type		DC			
	Quantity		4			
	Motor output	kW	0.56×4	0.56×4	0.56×2+0.92×2	0.56×2+0.92×2
	Static pressure	Pa	0-20 (default); 20-60 (customized)			
	Airflow rate	m ³ /h	34000	34000	42000	42000
Drive type		Direct				
Refrigerant	Type		R410A			
	Factory charge	kg	17×2	17×2	17+22	17+22
Pipe connections ³	Liquid pipe	mm	Φ19.1			
	Gas pipe	mm	Φ38.1			
Sound pressure level ⁴		dB(A)	70			
Sound power level		dB(A)	94			
Net dimensions (W×H×D)		mm	(1340×1635×825)×2		(1340×1635×825)+(1730×1830×850)	
Packed dimensions (W×H×D)		mm	(1405×1805×910)×2		(1405×1805×910)+(1800×2000×910)	
Net weight		kg	348×2		348+430	
Gross weight		kg	368×2		368+453	
Ambient temp. operation range	Cooling	°C	-5 ~ 48			
	Heating	°C	-25 ~ 24			

- Notes:
- Indoor air temperature 27°C DB, 19°C WB; outdoor air temperature 35°C DB; equivalent refrigerant piping length 7.5m with zero level difference.
 - Indoor air temperature 20°C DB; outdoor air temperature 7°C DB, 6°C WB; equivalent refrigerant piping length 7.5m with zero level difference.
 - Diameters given are those for the pipe connecting the outdoor unit combination to the first indoor branch joint for systems with total equivalent liquid piping lengths of less than 90m. For systems with total equivalent liquid piping lengths of 90m or longer, please refer to Part 3 "System Design and Installation" for connection piping diameters..
 - Sound pressure level is measured at a position 1m in front of the unit and 1.3m above the floor in a semi-anechoic chamber.

50-56HP

Table 2-1.6: 50-56HP specifications

HP			50	52	54	56
Model name (Combination unit)			MDVO-V61400V2R1BE	MDVO-V61460V2R1BE	MDVO-V61515V2R1BE	MDVO-V61570V2R1BE
Combination type			22HP+28HP	26HP+26HP	26HP+28HP	28HP+28HP
Power supply		V/Ph/Hz	380-415/3/50			
Cooling ¹	Capacity	kW	134.50	146.00	148.50	151.00
	Power input	kW	71.82	68.56	71.52	74.48
	EER		1.87	2.13	2.08	2.03
Heating ² (rated)	Capacity	kW	134.50	146.00	148.50	151.00
	Power input	kW	41.77	42.16	44.41	46.66
	COP		3.22	3.47	3.34	3.24
Heating ² (max)	Capacity	kW	150.40	163.00	165.70	168.30
	Power input	kW	50.42	50.45	53.79	57.13
	COP		2.98	3.23	3.08	2.95
SEER			5.28	5.83	5.62	5.43
η _{s,c}		%	208.1	230.3	221.7	214.3
COP			4.61	4.22	4.40	4.59
η _{s,h}		%	181.5	165.9	172.9	180.5
Connected indoor unit	Total capacity		50-130% of outdoor unit capacity			
	Maximum quantity		64			
Compressor	Type		DC inverter			
	Quantity		4			
	Oil type		FV68H			
	Start-up method		Soft start			
Fan	Type		Propeller			
	Motor type		DC			
	Quantity		4			
	Motor output	kW	0.56×2+0.92×2	0.92×4	0.92×4	0.92×4
	Static pressure	Pa	0-20 (default); 20-60 (customized)			
	Airflow rate	m ³ /h	42000	50000	50000	50000
Drive type		Direct				
Refrigerant	Type		R410A			
	Factory charge	kg	17+22	22×2	22×2	22×2
Pipe connections ³	Liquid pipe	mm	Φ19.1			Φ19.1
	Gas pipe	mm	Φ38.1			Φ41.3
Sound pressure level ⁴		dB(A)	70			
Sound power level		dB(A)	96			
Net dimensions (W×H×D)		mm	(1340×1635×825)+ (1730×1830×850)	(1730×1830×850)×2		
Packed dimensions (W×H×D)		mm	(1405×1805×910)+ (1800×2000×910)	(1800×2000×910)×2		
Net weight		kg	348+430	430×2		
Gross weight		kg	368+453	453×2		
Ambient temp. operation range	Cooling	°C	-5 ~ 48			
	Heating	°C	-25 ~ 24			

Notes:

- Indoor air temperature 27°C DB, 19°C WB; outdoor air temperature 35°C DB; equivalent refrigerant piping length 7.5m with zero level difference.
- Indoor air temperature 20°C DB; outdoor air temperature 7°C DB, 6°C WB; equivalent refrigerant piping length 7.5m with zero level difference.
- Diameters given are those for the pipe connecting the outdoor unit combination to the first indoor branch joint for systems with total equivalent liquid piping lengths of less than 90m. For systems with total equivalent liquid piping lengths of 90m or longer, please refer to Part 3 "System Design and Installation" for connection piping diameters..
- Sound pressure level is measured at a position 1m in front of the unit and 1.3m above the floor in a semi-anechoic chamber.

58-64HP

Table 2-1.7: 58-64HP specifications

HP			58	60	62	64
Model name (Combination unit)			MDVO-V61635V2R1BE	MDVO-V61685V2R1BE	MDVO-V61750V2R1BE	MDVO-V61800V2R1BE
Combination type			28HP+30HP	28HP+32HP	30HP+32HP	32HP+32HP
Power supply		V/Ph/Hz	380-415/3/50			
Cooling ¹	Capacity	kW	160.50	160.50	170.00	170.00
	Power input	kW	82.12	82.12	89.76	89.76
	EER			1.95	1.95	1.89
Heating ² (rated)	Capacity	kW	160.50	165.50	175.00	180.00
	Power input	kW	46.10	48.75	48.19	50.84
	COP			3.48	3.39	3.63
Heating ² (max)	Capacity	kW	179.20	184.20	195.00	200.00
	Power input	kW	56.10	58.89	57.86	60.66
	COP			3.19	3.13	3.37
SEER			5.28	5.28	5.15	5.15
η _{s,c}		%	208.1	208.1	202.8	202.8
COP			4.34	4.34	4.12	4.12
η _{s,h}		%	170.4	170.4	161.7	161.7
Connected indoor unit	Total capacity		50-130% of outdoor unit capacity			
	Maximum quantity		64			
Compressor	Type		DC inverter			
	Quantity		4			
	Oil type		FV68H			
	Start-up method		Soft start			
Fan	Type		Propeller			
	Motor type		DC			
	Quantity		4			
	Motor output	kW	0.92×4	0.92×4	0.92×4	0.92×4
	Static pressure	Pa	0-20 (default); 20-60 (customized)			
	Airflow rate	m ³ /h	49000	49000	48000	48000
Drive type		Direct				
Refrigerant	Type		R410A			
	Factory charge	kg	22+25	22+25	25+25	25×2
Pipe connections ³	Liquid pipe	mm	Φ19.1			
	Gas pipe	mm	Φ41.3			
Sound pressure level ⁴		dB(A)	70			
Sound power level		dB(A)	96			
Net dimensions (W×H×D)		mm	(1730×1830×850)×2			
Packed dimensions (W×H×D)		mm	(1800×2000×910)×2			
Net weight		kg	430+475		475×2	
Gross weight		kg	453+507		507×2	
Ambient temp. operation range	Cooling	°C	-5 ~ 48			
	Heating	°C	-25 ~ 24			

- Notes:
- Indoor air temperature 27°C DB, 19°C WB; outdoor air temperature 35°C DB; equivalent refrigerant piping length 7.5m with zero level difference.
 - Indoor air temperature 20°C DB; outdoor air temperature 7°C DB, 6°C WB; equivalent refrigerant piping length 7.5m with zero level difference.
 - Diameters given are those for the pipe connecting the outdoor unit combination to the first indoor branch joint for systems with total equivalent liquid piping lengths of less than 90m. For systems with total equivalent liquid piping lengths of 90m or longer, please refer to Part 3 "System Design and Installation" for connection piping diameters..
 - Sound pressure level is measured at a position 1m in front of the unit and 1.3m above the floor in a semi-anechoic chamber.

66-72HP

Table 2-1.8: 66-72HP specifications

HP			66	68	70	72
Model name (Combination unit)			MDVO-V61850V2R1BE	MDVO-V61915V2R1BE	MDVO-V61965V2R1BE	MDVO-V62020V2R1BE
Combination type			12HP+22HP+32HP	14HP+22HP+32HP	16HP+22HP+32HP	12HP+28HP+32HP
Power supply		V/Ph/Hz	380-415/3/50			
Cooling ¹	Capacity	kW	177.50	184.00	189.00	194.00
	Power input	kW	93.01	94.67	100.20	95.67
	EER		1.91	1.94	1.89	2.03
Heating ² (rated)	Capacity	kW	182.50	189.00	194.00	199.00
	Power input	kW	53.54	55.06	57.51	58.43
	COP		3.41	3.43	3.37	3.41
Heating ² (max)	Capacity	kW	203.70	211.20	216.20	221.70
	Power input	kW	63.80	65.70	68.61	70.50
	COP		3.19	3.21	3.15	3.14
SEER			5.28	5.35	5.24	5.40
η _{s,c}		%	208.1	211.0	206.5	212.9
COP			4.31	4.21	4.26	4.32
η _{s,h}		%	169.5	165.3	167.5	169.8
Connected indoor unit	Total capacity		50-130% of outdoor unit capacity			
	Maximum quantity		64			
Compressor	Type		DC inverter			
	Quantity		5			
	Oil type		FV68H			
	Start-up method		Soft start			
Fan	Type		Propeller			
	Motor type		DC			
	Quantity		5			
	Motor output	kW	0.56×3+0.92×2	0.56×2+0.92×3	0.56×2+0.92×3	0.56+0.92×4
	Static pressure	Pa	0-20 (default); 20-60 (customized)			
	Airflow rate	m ³ /h	52000	54000	54000	60000
Drive type		Direct				
Refrigerant	Type		R410A			
	Factory charge	kg	11+17+25	13+17+25	13+17+25	11+22+25
Pipe connections ³	Liquid pipe	mm	Φ19.1	Φ22.2		
	Gas pipe	mm	Φ41.3	Φ44.5		
Sound pressure level ⁴		dB(A)	71			
Sound power level		dB(A)	97			
Net dimensions (W×H×D)		mm	(990×1635×790)+ (1340×1635×825)+ (1730×1830×850)	(1340×1635×850)+ (1340×1635×825)+(1730×1830×850)		(990×1635×790)+ (1730×1830×850)×2
Packed dimensions (W×H×D)		mm	(1090×1805×860)+ (1405×1805×910)+ (1800×2000×910)	(1405×1805×910)×2+(1800×2000×910)		(1090×1805×860)+ (1800×2000×910)×2
Net weight		kg	227+348+475	277+348+475		227+430+475
Gross weight		kg	242+368+507	304+368+507		242+453+507
Ambient temp. operation range	Cooling	°C	-5 ~ 48			
	Heating	°C	-25 ~ 24			

Notes:

- Indoor air temperature 27°C DB, 19°C WB; outdoor air temperature 35°C DB; equivalent refrigerant piping length 7.5m with zero level difference.
- Indoor air temperature 20°C DB; outdoor air temperature 7°C DB, 6°C WB; equivalent refrigerant piping length 7.5m with zero level difference.
- Diameters given are those for the pipe connecting the outdoor unit combination to the first indoor branch joint for systems with total equivalent liquid piping lengths of less than 90m. For systems with total equivalent liquid piping lengths of 90m or longer, please refer to Part 3 "System Design and Installation" for connection piping diameters..
- Sound pressure level is measured at a position 1m in front of the unit and 1.3m above the floor in a semi-anechoic chamber.

74-80HP

Table 2-1.9: 74-80HP specifications

HP			74	76	78	80
Model name (Combination unit)			MDVO-V62075V2R1BE	MDVO-V62130V2R1BE	MDVO-V62185V2R1BE	MDVO-V62245V2R1BE
Combination type			20HP+22HP+32HP	22HP+22HP+32HP	22HP+24HP+32HP	22HP+26HP+32HP
Power supply		V/Ph/Hz	380-415/3/50			
Cooling ¹	Capacity	kW	200.00	203.00	211.00	217.00
	Power input	kW	109.09	114.04	111.31	113.74
	EER		1.83	1.78	1.90	1.91
Heating ² (rated)	Capacity	kW	205.00	208.00	216.00	222.00
	Power input	kW	58.92	62.30	61.15	64.94
	COP		3.48	3.34	3.53	3.42
Heating ² (max)	Capacity	kW	229.2	232.4	241.2	247.7
	Power input	kW	70.28	74.05	73.13	77.41
	COP		3.26	3.14	3.30	3.20
SEER			5.19	5.12	5.29	5.34
η _{s,c}		%	204.7	201.7	208.5	210.6
COP			4.35	4.42	4.36	4.29
η _{s,h}		%	171.0	173.8	171.6	168.7
Connected indoor unit	Total capacity		50-130% of outdoor unit capacity			
	Maximum quantity		64			
Compressor	Type		DC inverter			
	Quantity		6			
	Oil type		FV68H			
	Start-up method		Soft start			
Fan	Type		Propeller			
	Motor type		DC			
	Quantity		6			
	Motor output	kW	0.56×4+0.92×2	0.56×4+0.92×2	0.56×2+0.92×4	0.56×2+0.92×4
	Static pressure	Pa	0-20 (default); 20-60 (customized)			
	Airflow rate	m ³ /h	58000	58000	66000	66000
Drive type		Direct				
Refrigerant	Type		R410A			
	Factory charge	kg	17×2+25	17×2+25	17+22+25	17+22+25
Pipe connections ³	Liquid pipe	mm	Φ22.2			
	Gas pipe	mm	Φ44.5			
Sound pressure level ⁴		dB(A)	72			
Sound power level		dB(A)	98			
Net dimensions (W×H×D)		mm	(1340×1635×825)×2+(1730×1830×850)		(1340×1635×825)+(1730×1830×850)×2	
Packed dimensions (W×H×D)		mm	(1405×1805×910)×2+(1800×2000×910)		(1405×1805×910)+(1800×2000×910)×2	
Net weight		kg	348×2+475		348+430+475	
Gross weight		kg	368×2+507		368+453+507	
Ambient temp. operation range	Cooling	°C	-5 ~ 48			
	Heating	°C	-25 ~ 24			

Notes:

- Indoor air temperature 27°C DB, 19°C WB; outdoor air temperature 35°C DB; equivalent refrigerant piping length 7.5m with zero level difference.
- Indoor air temperature 20°C DB; outdoor air temperature 7°C DB, 6°C WB; equivalent refrigerant piping length 7.5m with zero level difference.
- Diameters given are those for the pipe connecting the outdoor unit combination to the first indoor branch joint for systems with total equivalent liquid piping lengths of less than 90m. For systems with total equivalent liquid piping lengths of 90m or longer, please refer to Part 3 "System Design and Installation" for connection piping diameters..
- Sound pressure level is measured at a position 1m in front of the unit and 1.3m above the floor in a semi-anechoic chamber.

82-88HP

Table 2-1.10: 82-88HP specifications

HP			82	84	86	88
Model name (Combination unit)			MDVO-V62300V2R1BE	MDVO-V62360V2R1BE	MDVO-V62415V2R1BE	MDVO-V62470V2R1BE
Combination type			22HP+28HP+32HP	26HP+26HP+32HP	26HP+28HP+32HP	28HP+28HP+32HP
Power supply		V/Ph/Hz	380-415/3/50			
Cooling ¹	Capacity	kW	219.50	231.00	233.50	236.00
	Power input	kW	116.70	113.44	116.40	119.36
	EER		1.88	2.04	2.01	1.98
Heating ² (rated)	Capacity	kW	224.50	236.00	238.50	241.00
	Power input	kW	67.19	67.58	69.83	72.08
	COP		3.34	3.49	3.42	3.34
Heating ² (max)	Capacity	kW	250.40	263.00	265.70	268.30
	Power input	kW	80.75	80.78	84.12	87.46
	COP		3.10	3.26	3.16	3.07
SEER			5.23	5.56	5.44	5.33
η _{s,c}		%	206.1	219.3	214.5	210.1
COP			4.42	4.19	4.30	4.41
η _{s,h}		%	173.7	164.6	169.0	173.6
Connected indoor unit	Total capacity		50-130% of outdoor unit capacity			
	Maximum quantity		64			
Compressor	Type		DC inverter			
	Quantity		6			
	Oil type		FV68H			
	Start-up method		Soft start			
Fan	Type		Propeller			
	Motor type		DC			
	Quantity		6			
	Motor output	kW	0.56×2+0.92×4	0.92×6	0.92×6	0.92×6
	Static pressure	Pa	0-20 (default); 20-60 (customized)			
	Airflow rate	m ³ /h	66000	74000	74000	74000
Drive type		Direct				
Refrigerant	Type		R410A			
	Factory charge	kg	17+22+25	22×2+25	22×2+25	22×2+25
Pipe connections ³	Liquid pipe	mm	Φ22.2	Φ25.4		
	Gas pipe	mm	Φ44.5	Φ50.8		
Sound pressure level ⁴		dB(A)	72			
Sound power level		dB(A)	98			
Net dimensions (W×H×D)		mm	(1340×1635×825)+ (1730×1830×850)×2	(1730×1830×850)×3		
Packed dimensions (W×H×D)		mm	(1405×1805×910)+ (1800×2000×910)×2	(1800×2000×910)×3		
Net weight		kg	348+430+475	430×2+475		
Gross weight		kg	368+453+507	453×2+507		
Ambient temp. operation range	Cooling	°C	-5 ~ 48			
	Heating	°C	-25 ~ 24			

Notes:

- Indoor air temperature 27°C DB, 19°C WB; outdoor air temperature 35°C DB; equivalent refrigerant piping length 7.5m with zero level difference.
- Indoor air temperature 20°C DB; outdoor air temperature 7°C DB, 6°C WB; equivalent refrigerant piping length 7.5m with zero level difference.
- Diameters given are those for the pipe connecting the outdoor unit combination to the first indoor branch joint for systems with total equivalent liquid piping lengths of less than 90m. For systems with total equivalent liquid piping lengths of 90m or longer, please refer to Part 3 "System Design and Installation" for connection piping diameters..
- Sound pressure level is measured at a position 1m in front of the unit and 1.3m above the floor in a semi-anechoic chamber.

90-96HP
Table 2-1.11: 90-96HP specifications

HP			90	92	94	96
Model name (Combination unit)			MDVO-V62535V2R1BE	MDVO-V62585V2R1BE	MDVO-V62650V2R1BE	MDVO-V62700V2R1BE
Combination type			28HP+30HP+32HP	28HP+32HP+32HP	30HP+32HP+32HP	32HP+32HP+32HP
Power supply		V/Ph/Hz	380-415/3/50			
Cooling ¹	Capacity	kW	245.50	245.50	255.00	255.00
	Power input	kW	127.00	127.00	134.64	134.64
	EER		1.93	1.93	1.89	1.89
Heating ² (rated)	Capacity	kW	250.50	255.50	265.00	270.00
	Power input	kW	71.52	74.17	73.61	76.26
	COP		3.50	3.44	3.60	3.54
Heating ² (max)	Capacity	kW	279.20	284.20	295.00	300.00
	Power input	kW	86.42	89.22	88.19	90.98
	COP		3.23	3.18	3.35	3.30
SEER			5.23	5.23	5.15	5.15
η _{s,c}		%	206.3	206.3	202.8	202.8
COP			4.26	4.26	4.12	4.12
η _{s,h}		%	167.4	167.4	161.7	161.7
Connected indoor unit	Total capacity		50-130% of outdoor unit capacity			
	Maximum quantity		64			
Compressor	Type		DC inverter			
	Quantity		6			
	Oil type		FV68H			
	Start-up method		Soft start			
Fan	Type		Propeller			
	Motor type		DC			
	Quantity		6			
	Motor output	kW	0.92×6	0.92×6	0.92×6	0.92×6
	Static pressure	Pa	0-20 (default); 20-60 (customized)			
	Airflow rate	m ³ /h	73000	73000	72000	72000
Drive type		Direct				
Refrigerant	Type		R410A			
	Factory charge	kg	22+25×2	22+25×2	25+25×2	25×3
Pipe connections ³	Liquid pipe	mm	Φ25.4			
	Gas pipe	mm	Φ50.8			
Sound pressure level ⁴		dB(A)	72			
Sound power level		dB(A)	98			
Net dimensions (W×H×D)		mm	(1730×1830×850)×3			
Packed dimensions (W×H×D)		mm	(1800×2000×910)×3			
Net weight		kg	430+475×2			475×3
Gross weight		kg	453+507×2			507×3
Ambient temp. operation range	Cooling	°C	-5 ~ 48			
	Heating	°C	-25 ~ 24			

Notes:

- Indoor air temperature 27°C DB, 19°C WB; outdoor air temperature 35°C DB; equivalent refrigerant piping length 7.5m with zero level difference.
- Indoor air temperature 20°C DB; outdoor air temperature 7°C DB, 6°C WB; equivalent refrigerant piping length 7.5m with zero level difference.
- Diameters given are those for the pipe connecting the outdoor unit combination to the first indoor branch joint for systems with total equivalent liquid piping lengths of less than 90m. For systems with total equivalent liquid piping lengths of 90m or longer, please refer to Part 3 "System Design and Installation" for connection piping diameters..
- Sound pressure level is measured at a position 1m in front of the unit and 1.3m above the floor in a semi-anechoic chamber.

2 Dimensions

2.1 Single Units

8/10/12HP

Figure 2-2.1: 8/10/12 dimensions (unit: mm)

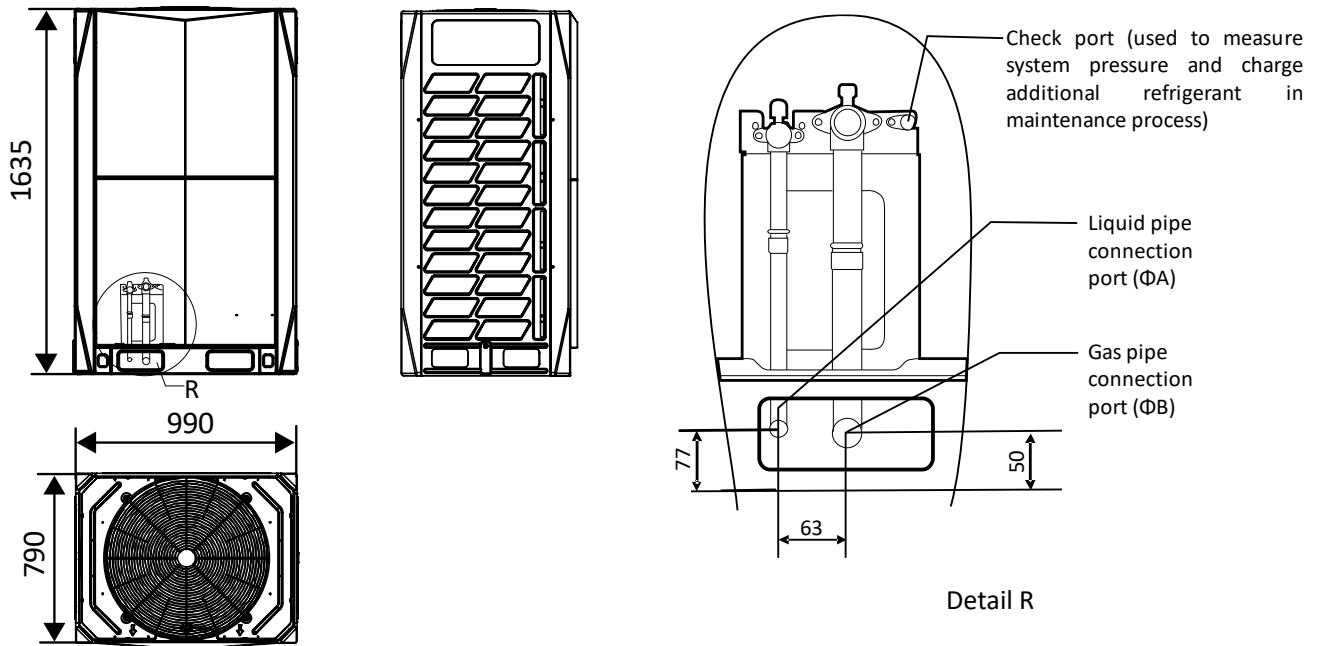

Table 2-2.1: 8/10/12HP connection piping diameter (unit: mm)

Size	8HP	10HP	12HP
A	Φ12.7	Φ12.7	Φ15.9
B	Φ25.4	Φ25.4	Φ28.6

14/16HP

Figure 2-2.2: 14/16HP dimensions (unit: mm)

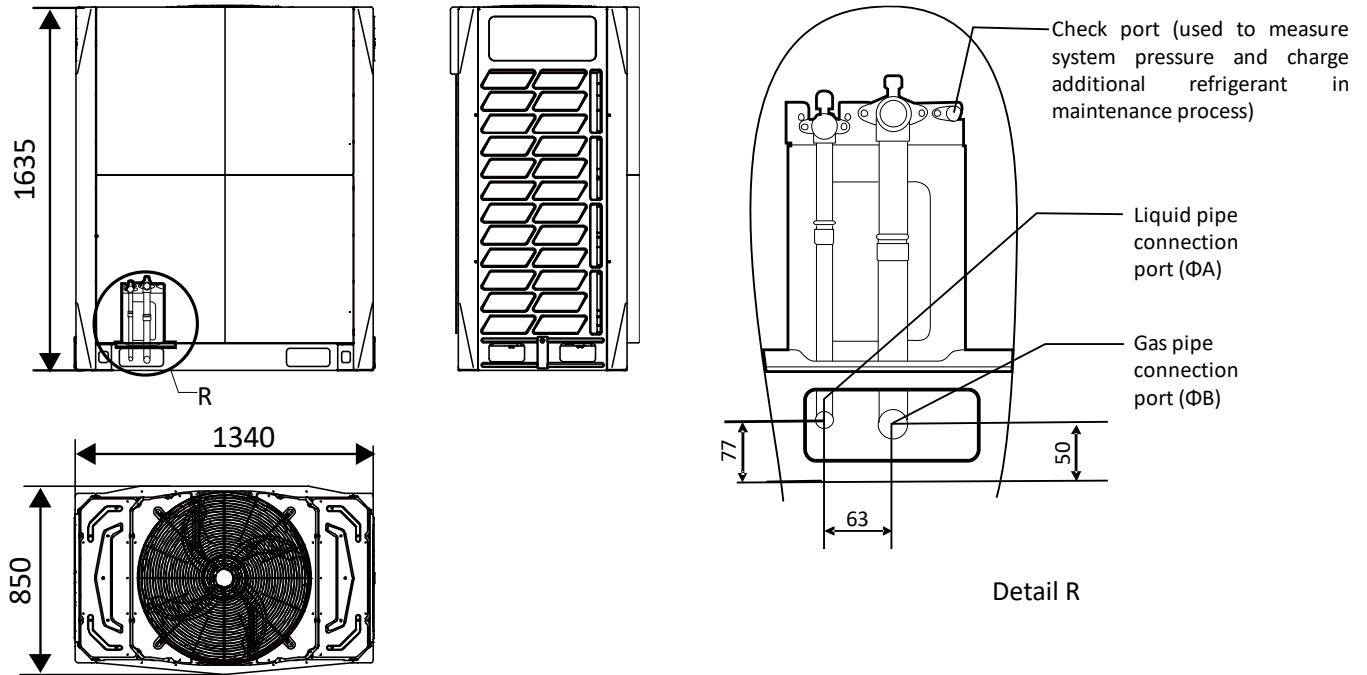

Table 2-2.1: 14/16HP connection piping diameter (unit: mm)

Size	14HP	16HP
A	Φ15.9	Φ15.9
B	Φ31.8	Φ31.8

Figure 2-2.3: 18/20/22HP dimensions (unit: mm)

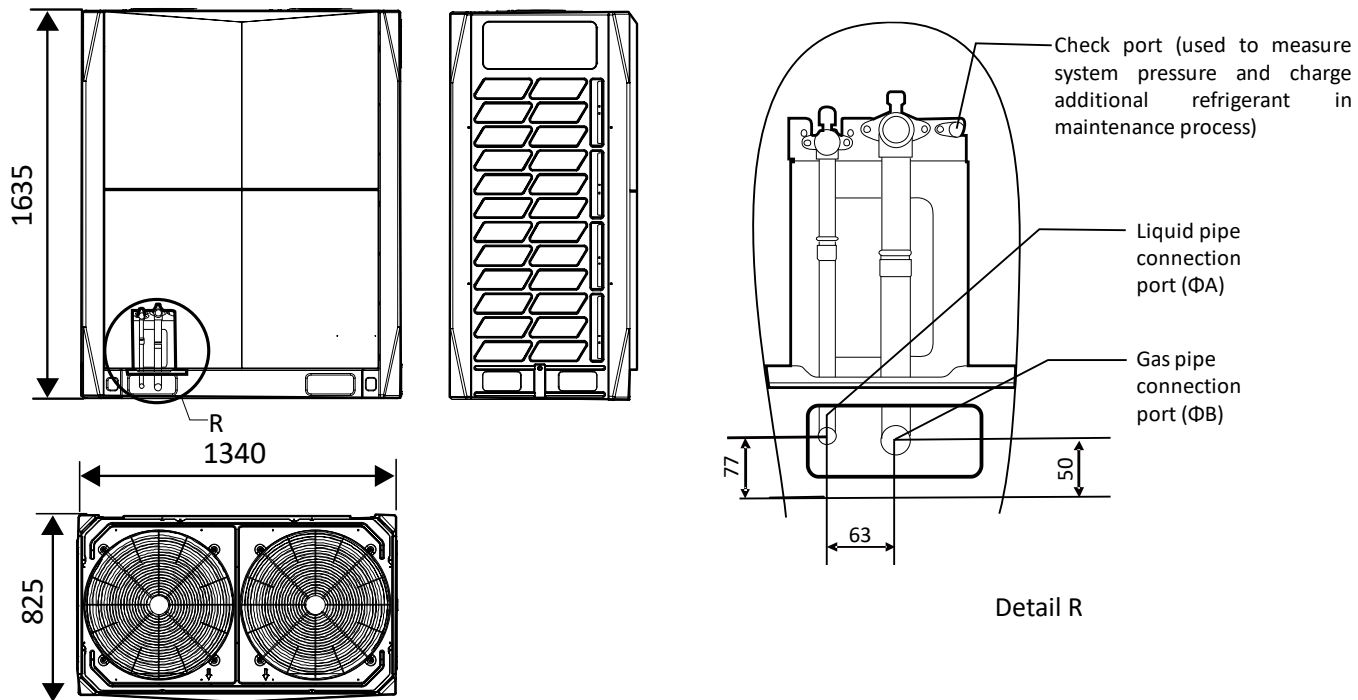

Table 2-2.1: 18/20/22HP connection piping diameter (unit: mm)

Size	18HP	20HP	22HP
A	Φ19.1	Φ19.1	Φ19.1
B	Φ31.8	Φ31.8	Φ31.8

24/26/28/30/32HP

Figure 2-2.4: 24/26/28/30/32HP dimensions (unit: mm)

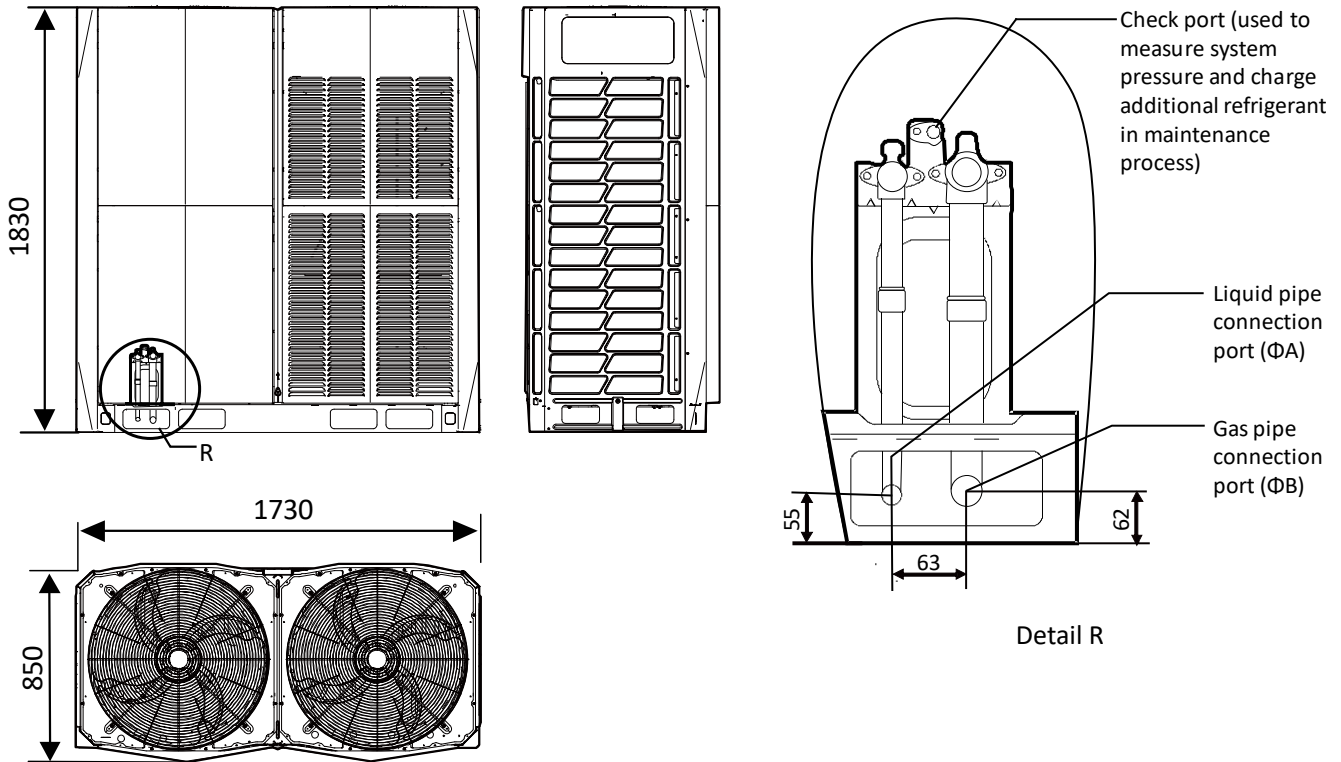

Table 2-2.1: 24/26/28/30/32HP connection piping diameter (unit: mm)

Size	24HP	26HP	28HP	30HP	32HP
A	Φ19.1	Φ22.2	Φ22.2	Φ22.2	Φ22.2
B	Φ31.8	Φ31.8	Φ31.8	Φ38.1	Φ38.1

2.2 Combinations of Units

34HP

Figure 2-2.5: 34HP dimensions (unit: mm)

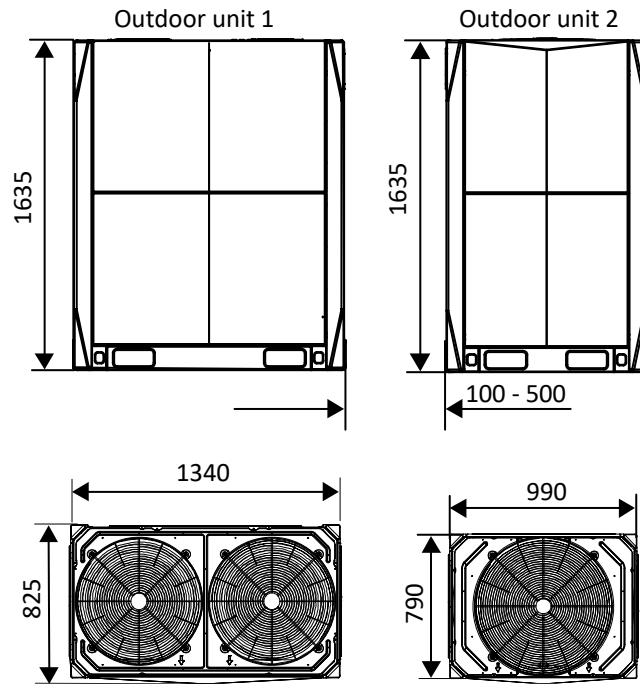

36/38HP

Figure 2-2.6: 36/38HP dimensions (unit: mm)

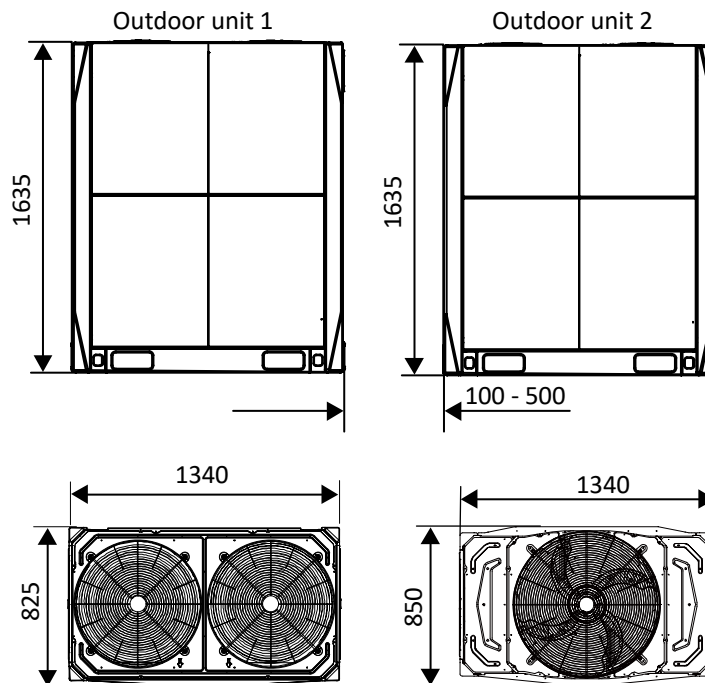

40HP

Figure 2-2.7: 40HP dimensions (unit: mm)

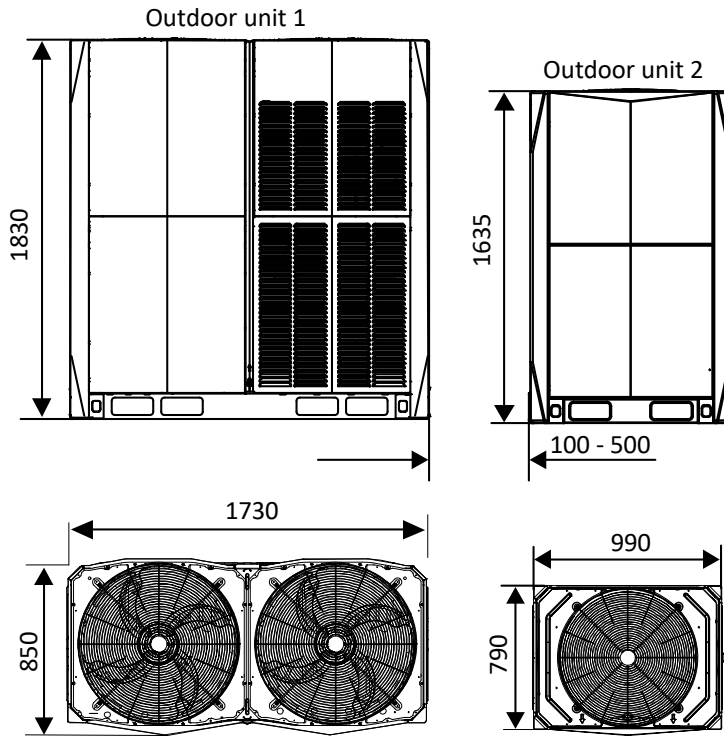

42/44HP

Figure 2-2.8: 42/44HP dimensions (unit: mm)

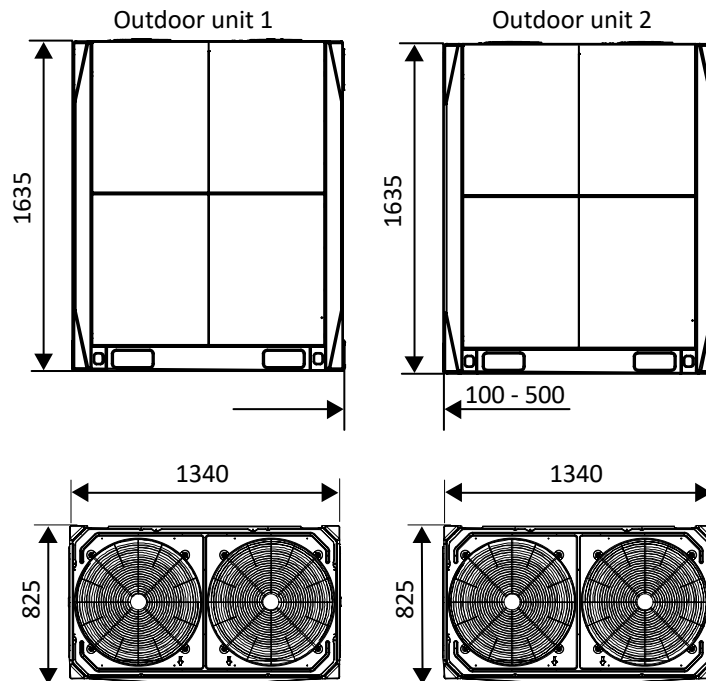

46/48/50HP

Figure 2-2.9: 46/48/50 dimensions (unit: mm)

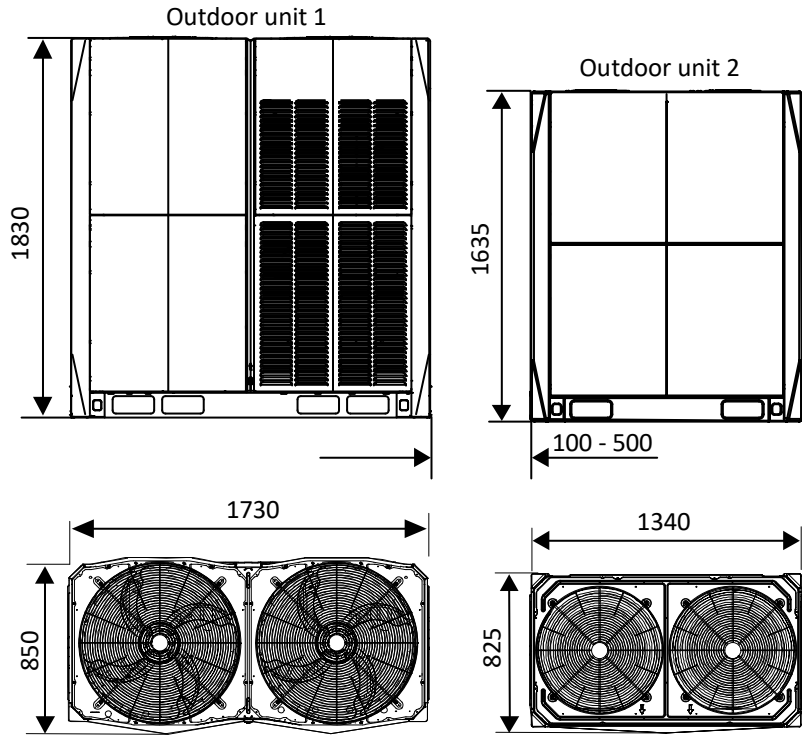

52/54/56/58/60/62/64HP

Figure 2-2.10: 52/54/56/58/60/62/64HP dimensions (unit: mm)

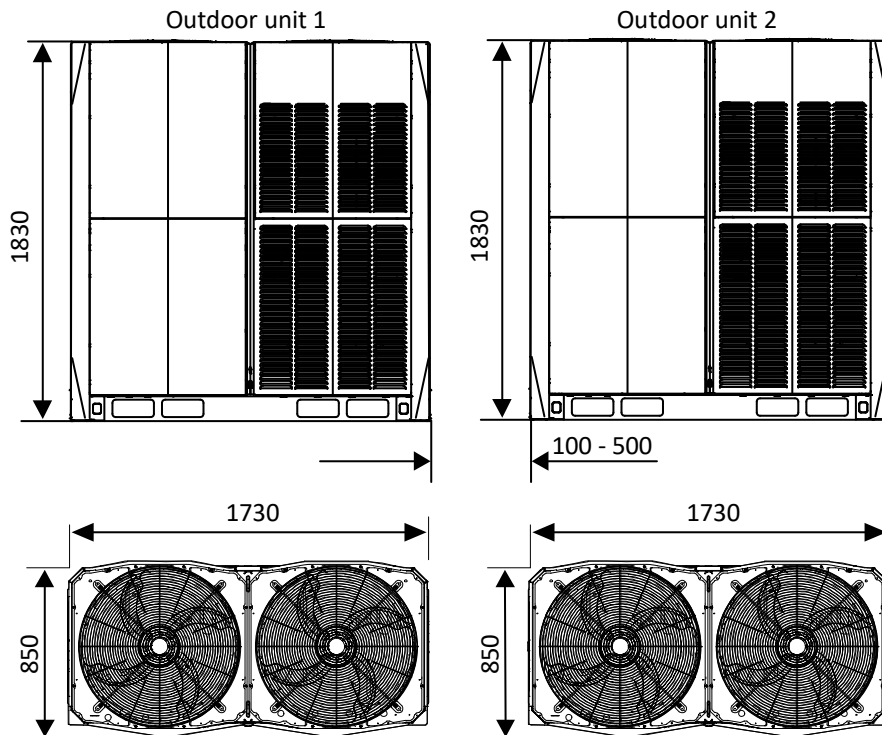

66HP

Figure 2-2.11: 66HP dimensions (unit: mm)

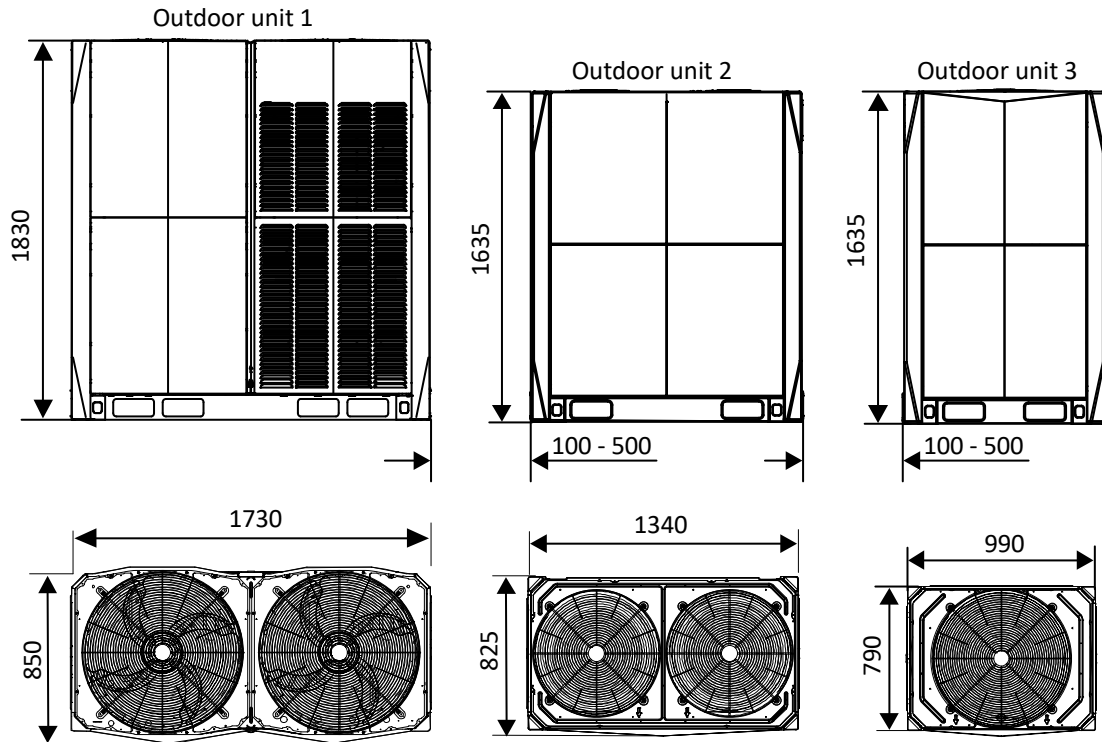

68/70HP

Figure 2-2.12: 68/70HP dimensions (unit: mm)

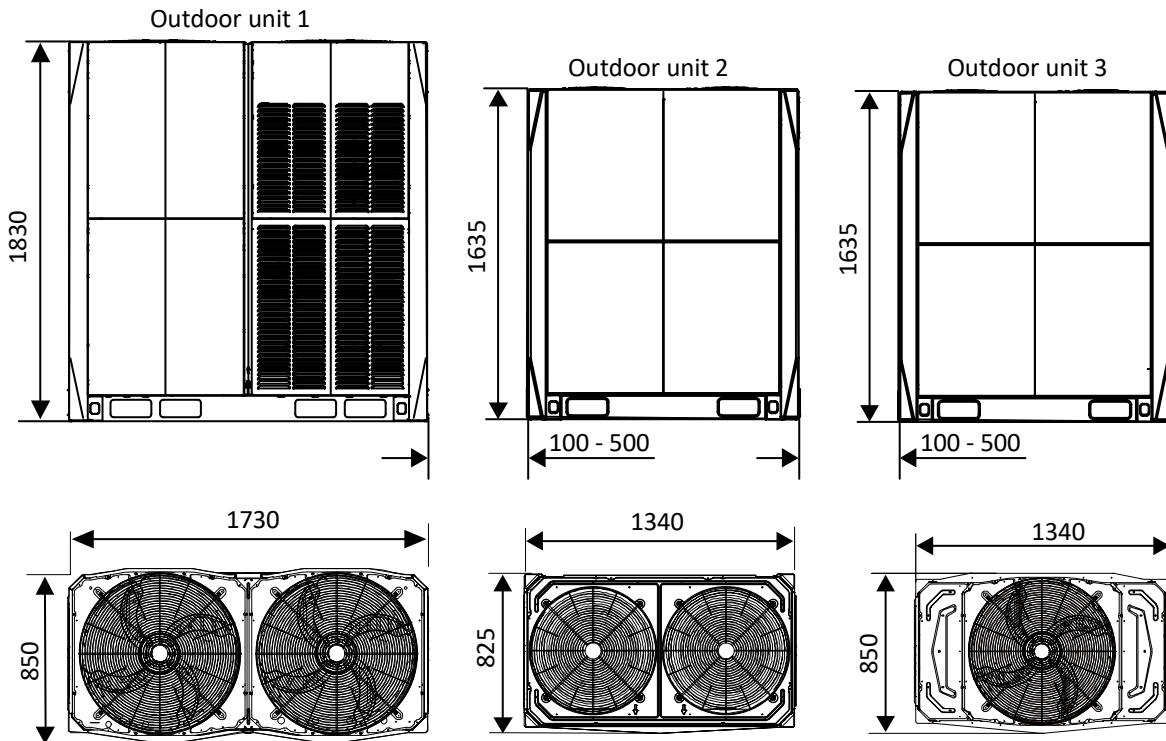

72HP

Figure 2-2.13: 72HP dimensions (unit: mm)

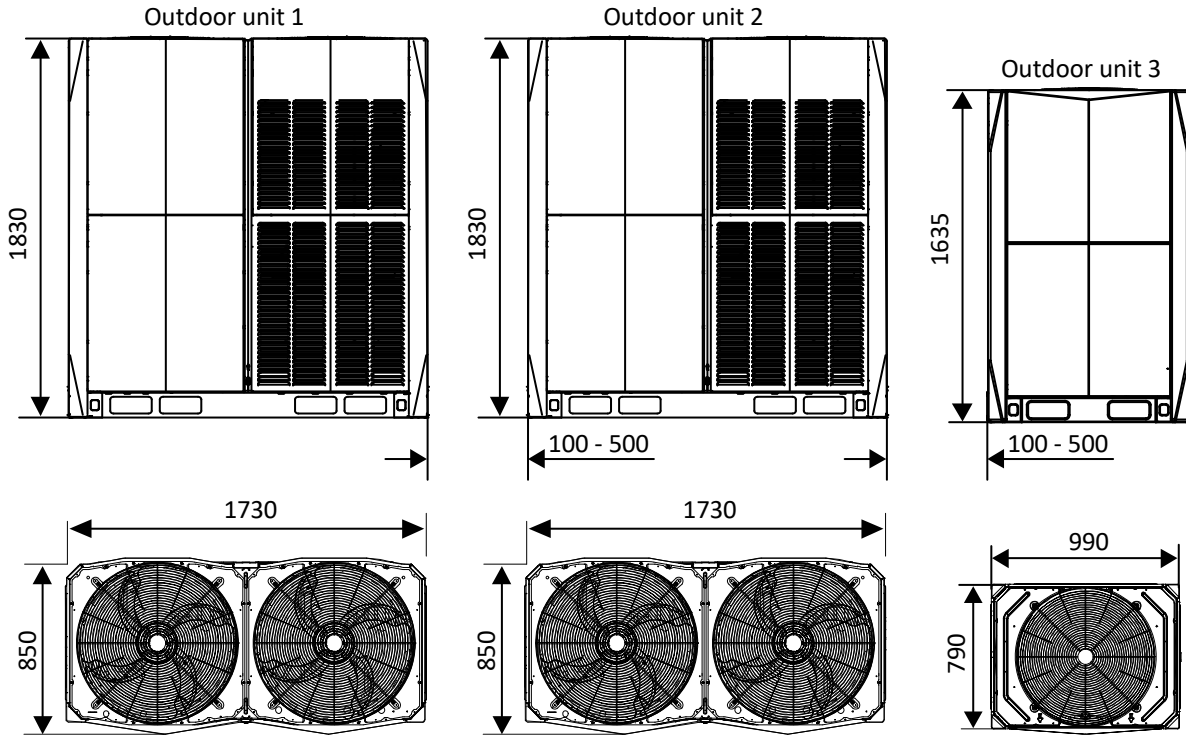

74/76HP

Figure 2-2.14: 74/76HP dimensions (unit: mm)

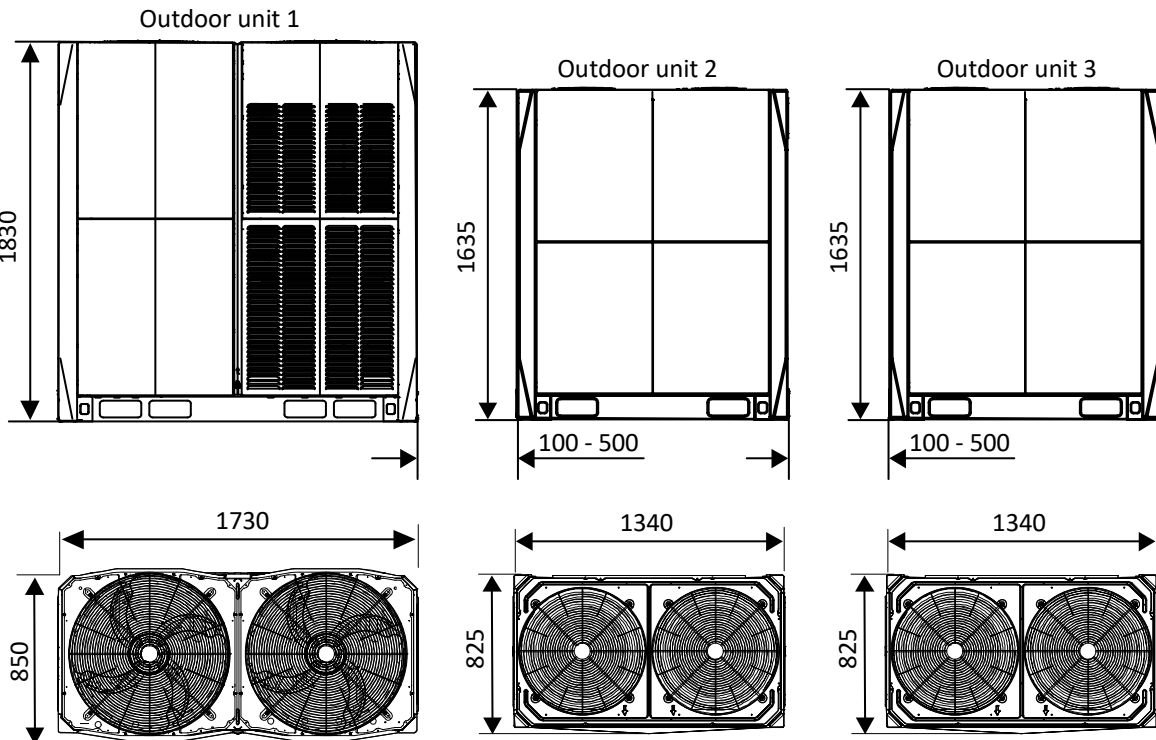

78/80/82HP

Figure 2-2.15: 78/80/82HP dimensions (unit: mm)

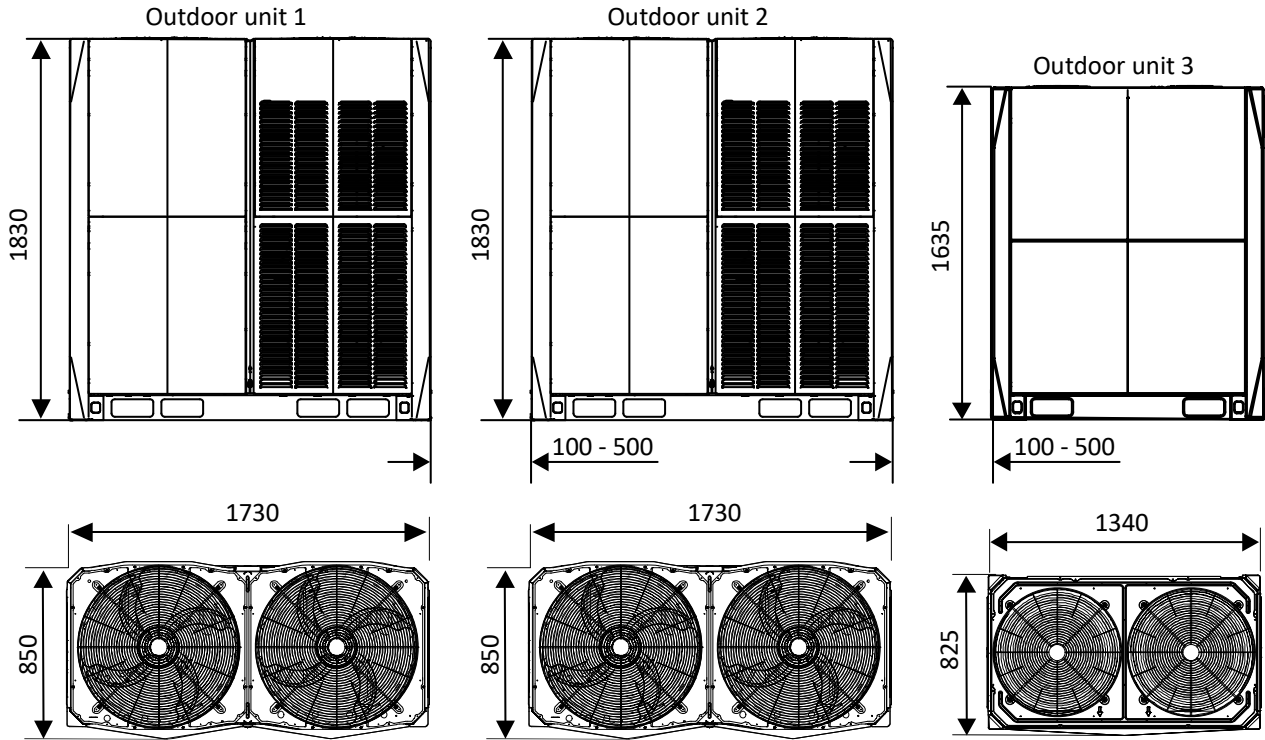

84/86/88/90/92/94/96HP

Figure 2-2.16: 84/86/88/90/92/94/96HP dimensions (unit: mm)

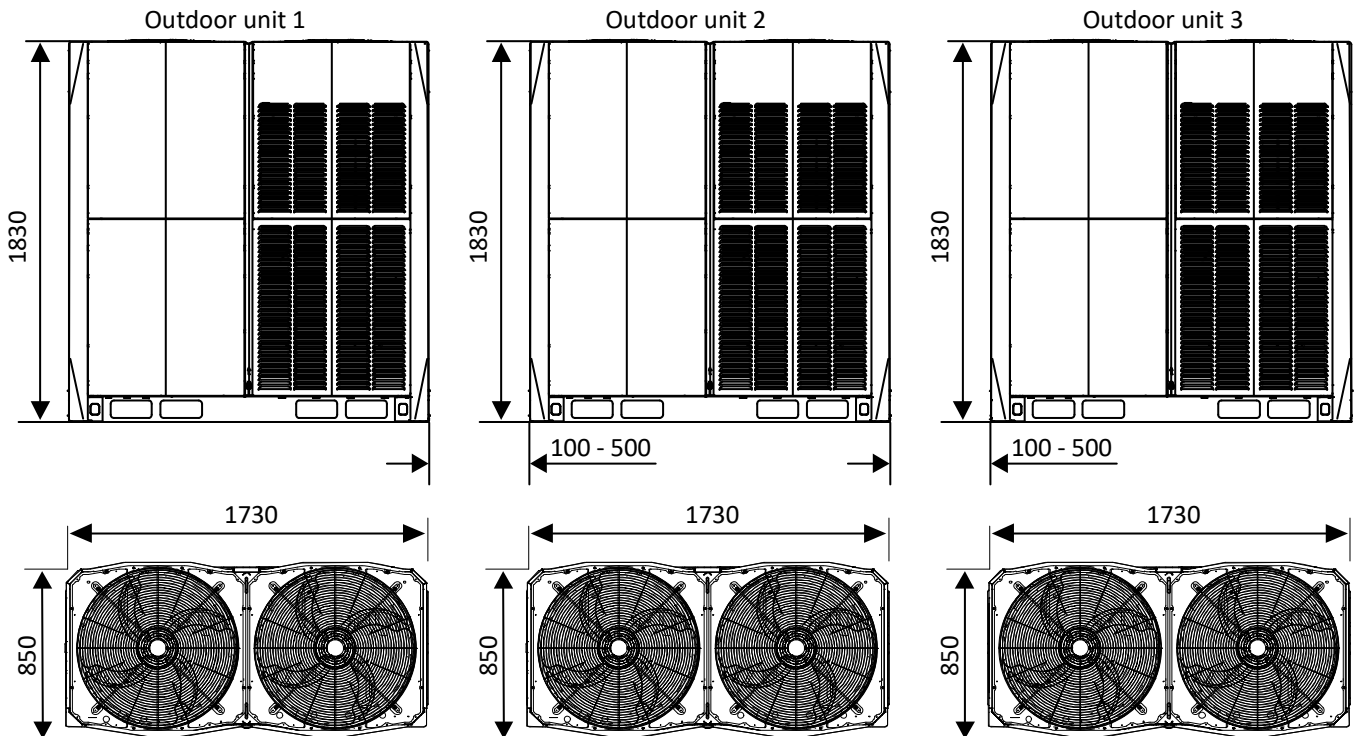

3 Installation Space Requirements

For single unit installation

Figure 2-3.1: Single unit installation (unit: mm)

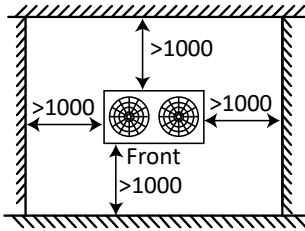

For single row installation

Figure 2-3.2: Single row installation (unit: mm)

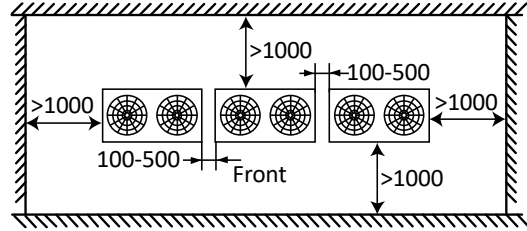

For multi-row installation

Figure 2-3.3: Multi-row installation (unit: mm)

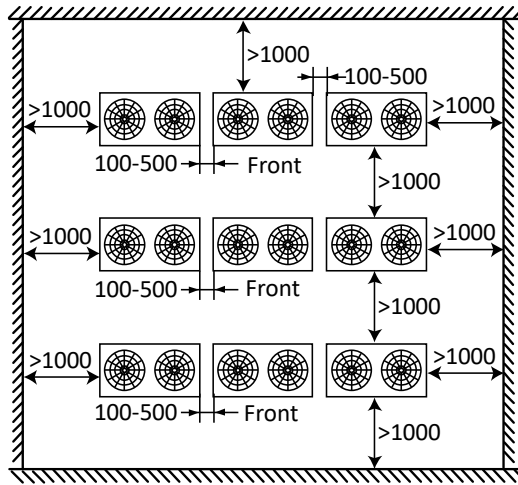

Depending on the height of adjacent walls relative to the height of the units, ducting may be required to ensure proper air discharge. In the situation depicted in Figure 2-3.4, the vertical section of ducting should be at least $H-h$ high.

Figure 2-3.4: Top of unit below top of adjacent wall

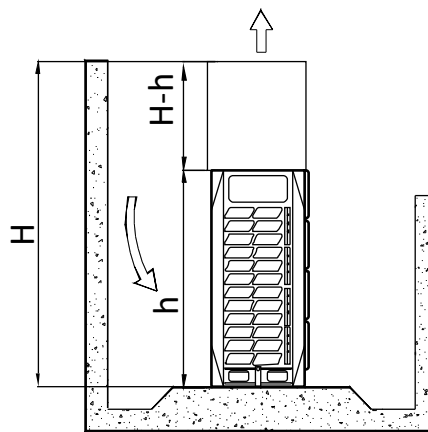

4 Piping Diagrams

8/10/12HP

Figure 2-4.1: 8/10/12HP piping diagram

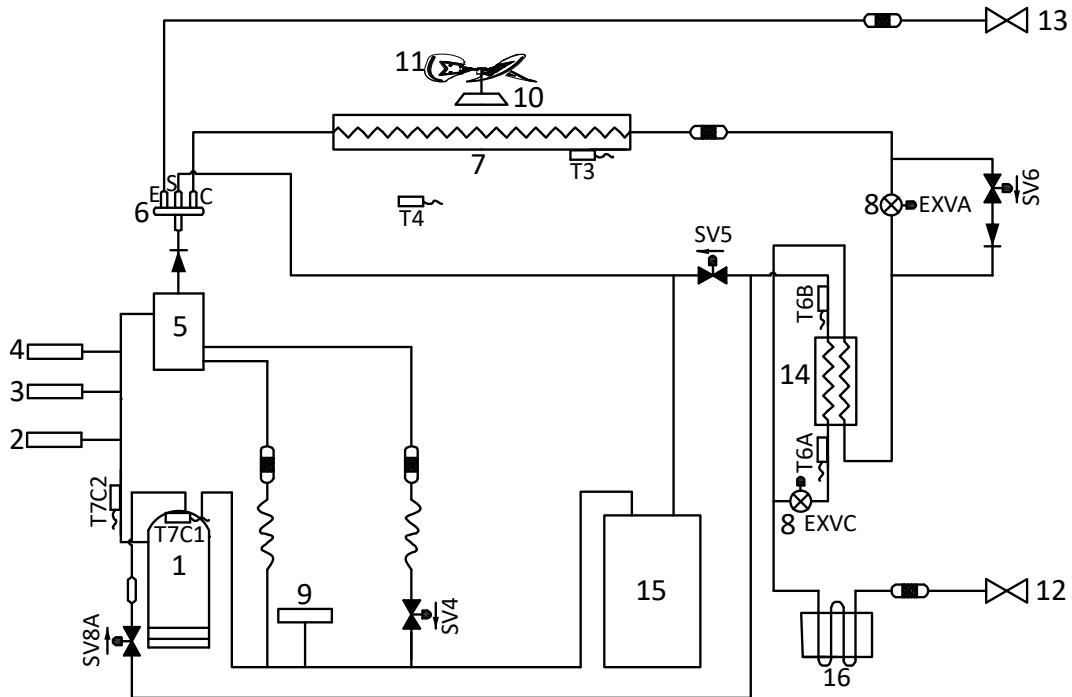

Legend			
No.	Parts name	No.	Parts name
1	Compressor	14	Plate heat exchanger
2	Discharge temperature switch	15	Accumulator
3	High pressure switch	16	Heat exchanger cooling electric control box
4	High pressure sensor	T3	Heat exchanger temperature sensor
5	Oil separator	T4	Outdoor ambient temperature sensor
6	Four-way valve	T6A	Plate heat exchanger inlet temperature sensor
7	Heat exchanger	T6B	Plate heat exchanger outlet temperature sensor
8	Electronic expansion valve (EXV)	T7C1	Compressor A discharge temperature sensor
9	Low pressure switch	T7C2	Discharge pipe temperature sensor
10	Fan motor	SV4	Oil return valve
11	Fan	SV5	Fast defrosting (in heating) and unloading (in cooling) valve
12	Stop valve (liquid side)	SV6	Refrigerant bypass EXV valve
13	Stop valve (gas side)	SV8A	Compressor A vapor injection valve

Figure 2-4.2: 14/16HP piping diagram

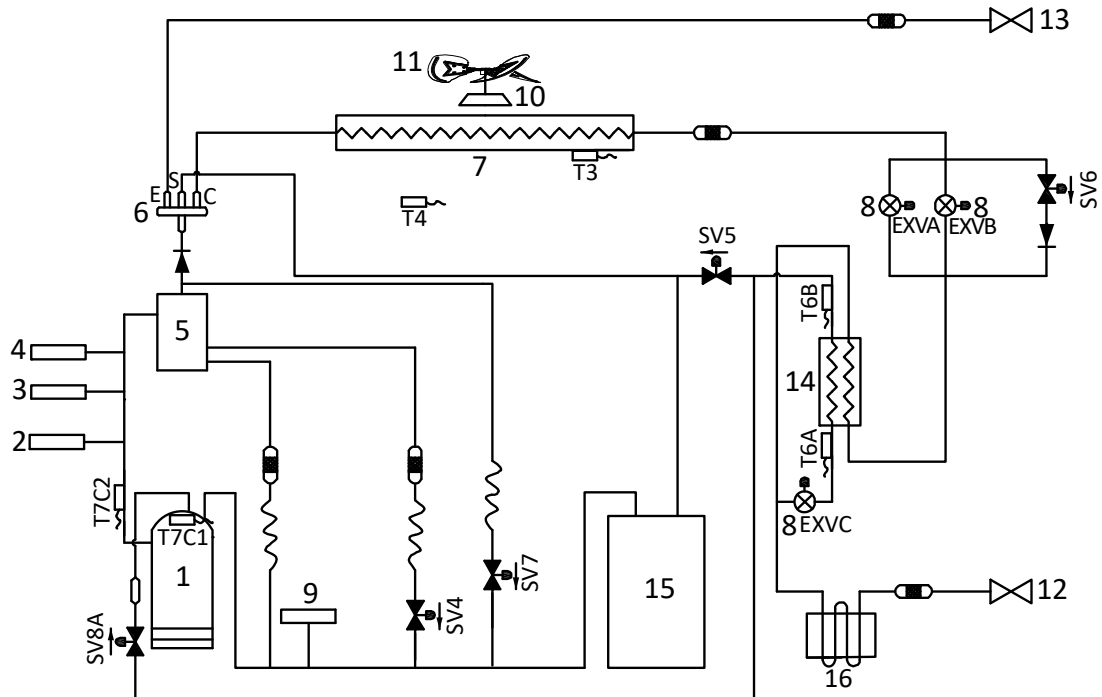

Legend		Legend	
No.	Parts name	No.	Parts name
1	Compressor	15	Accumulator
2	Discharge temperature switch	16	Heat exchanger cooling electric control box
3	High pressure switch	T3	Heat exchanger temperature sensor
4	High pressure sensor	T4	Outdoor ambient temperature sensor
5	Oil separator	T6A	Plate heat exchanger inlet temperature sensor
6	Four-way valve	T6B	Plate heat exchanger outlet temperature sensor
7	Heat exchanger	T7C1	Compressor A discharge temperature sensor
8	Electronic expansion valve (EXV)	T7C2	Discharge pipe temperature sensor
9	Low pressure switch	SV4	Oil return valve
10	Fan motor	SV5	Fast defrosting (in heating) and unloading (in cooling) valve
11	Fan	SV6	Refrigerant bypass EXV valve
12	Stop valve (liquid side)	SV7	Refrigerant bypass indoor units valve
13	Stop valve (gas side)	SV8A	Compressor A vapor injection valve
14	Plate heat exchanger		

Figure 2-4.3: 18/20/22HP piping diagram

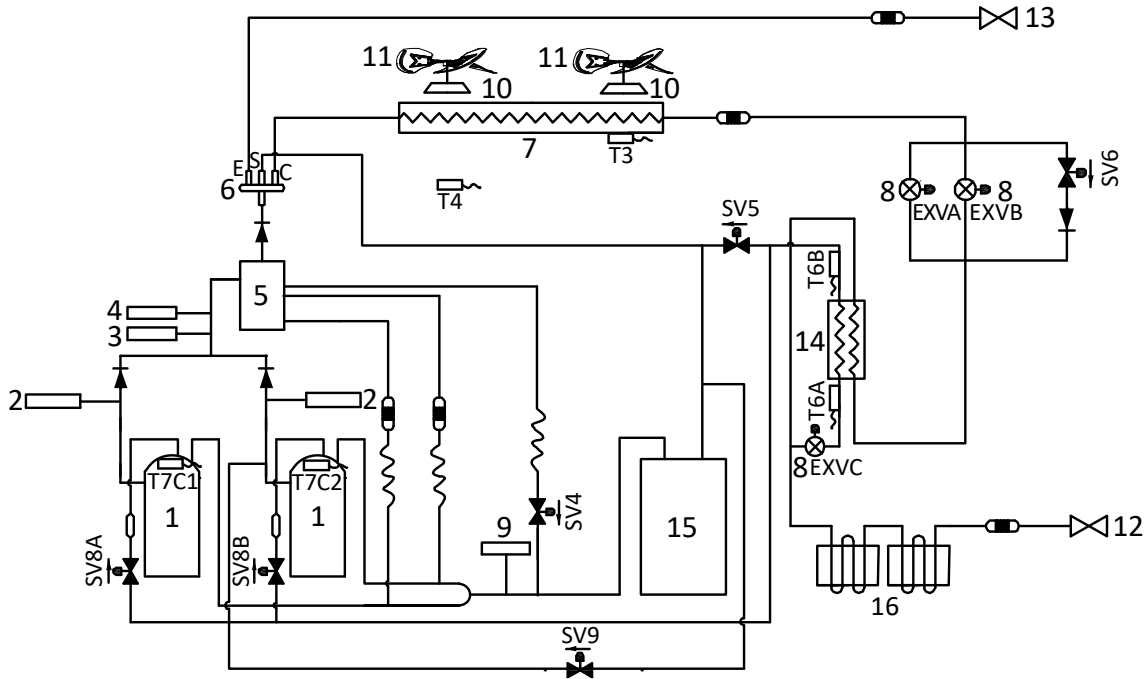

Legend		Legend	
No.	Parts name	No.	Parts name
1	Compressor	15	Accumulator
2	Discharge temperature switch	16	Heat exchanger cooling electric control box
3	High pressure switch	T3	Heat exchanger temperature sensor
4	High pressure sensor	T4	Outdoor ambient temperature sensor
5	Oil separator	T6A	Plate heat exchanger inlet temperature sensor
6	Four-way valve	T6B	Plate heat exchanger outlet temperature sensor
7	Heat exchanger	T7C1	Compressor A discharge temperature sensor
8	Electronic expansion valve (EXV)	T7C2	Compressor B discharge temperature sensor
9	Low pressure switch	SV4	Oil return valve
10	Fan motor	SV5	Fast defrosting (in heating) and unloading (in cooling) valve
11	Fan	SV6	Refrigerant bypass EXV valve
12	Stop valve (liquid side)	SV8A	Compressor A vapor injection valve
13	Stop valve (gas side)	SV8B	Compressor B vapor injection valve
14	Plate heat exchanger	SV9	Compressor B pressure balance valve

Figure 2-4.4: 24/26/28HP piping diagram

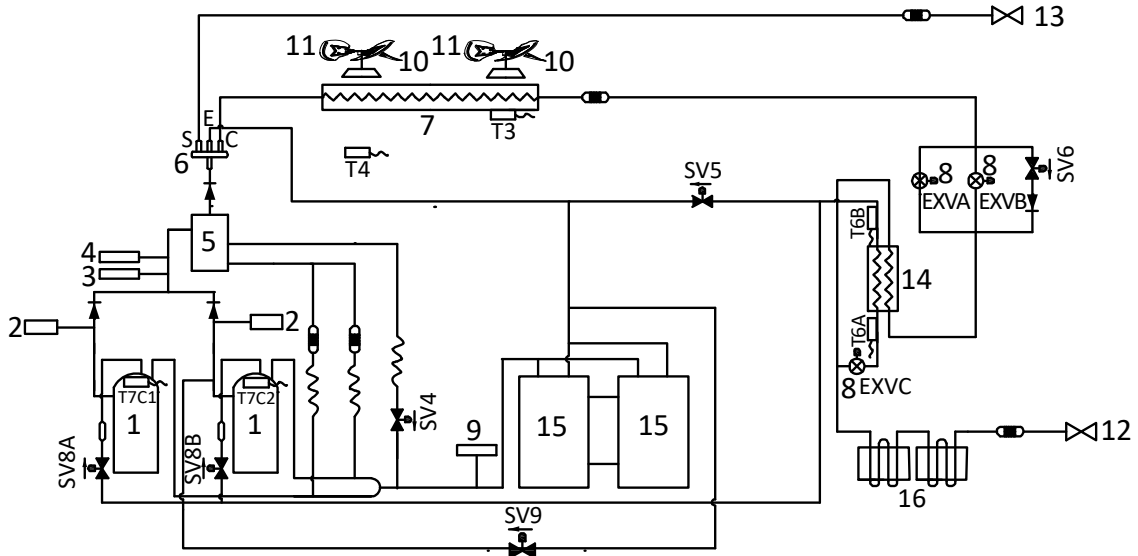

Legend		No.	Parts name
1	Compressor	15	Accumulator
2	Discharge temperature switch	16	Heat exchanger cooling electric control box
3	High pressure switch	T3	Heat exchanger temperature sensor
4	High pressure sensor	T4	Outdoor ambient temperature sensor
5	Oil separator	T6A	Plate heat exchanger inlet temperature sensor
6	Four-way valve	T6B	Plate heat exchanger outlet temperature sensor
7	Heat exchanger	T7C1	Compressor A discharge temperature sensor
8	Electronic expansion valve (EXV)	T7C2	Compressor B discharge temperature sensor
9	Low pressure switch	SV4	Oil return valve
10	Fan motor	SV5	Fast defrosting (in heating) and unloading (in cooling) valve
11	Fan	SV6	Refrigerant bypass EXV valve
12	Stop valve (liquid side)	SV8A	Compressor A vapor injection valve
13	Stop valve (gas side)	SV8B	Compressor B vapor injection valve
14	Plate heat exchanger	SV9	Compressor B pressure balance valve

30/32HP

Figure 2-4.5: 30/32HP piping diagram

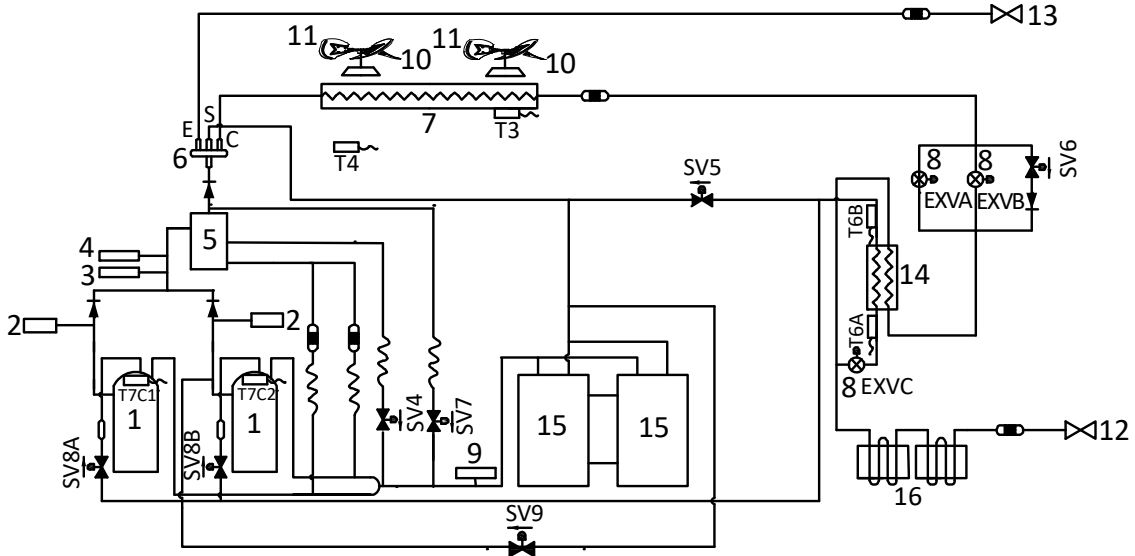

Legend		Legend	
No.	Parts name	No.	Parts name
1	Compressor	16	Heat exchanger cooling electric control box
2	Discharge temperature switch	T3	Heat exchanger temperature sensor
3	High pressure switch	T4	Outdoor ambient temperature sensor
4	High pressure sensor	T6A	Plate heat exchanger inlet temperature sensor
5	Oil separator	T6B	Plate heat exchanger outlet temperature sensor
6	Four-way valve	T7C1	Compressor A discharge temperature sensor
7	Heat exchanger	T7C2	Compressor B discharge temperature sensor
8	Electronic expansion valve (EXV)	SV4	Oil return valve
9	Low pressure switch	SV5	Fast defrosting (in heating) and unloading (in cooling) valve
10	Fan motor	SV6	Refrigerant bypass EXV valve
11	Fan	SV7	Refrigerant bypass indoor units valve
12	Stop valve (liquid side)	SV8A	Compressor A vapor injection valve
13	Stop valve (gas side)	SV8B	Compressor B vapor injection valve
14	Plate heat exchanger	SV9	Compressor B pressure balance valve
15	Accumulator		

Key components:

1. **Oil separator:**
Separates oil from gas refrigerant pumped out of the compressor and quickly returns it to the compressor. Separation efficiency is up to 99%.
2. **Accumulator:**
Stores liquid refrigerant and oil to protect compressor from liquid hammering.
3. **Electronic expansion valve (EXV):**
Controls refrigerant flow and reduces refrigerant pressure.
4. **Four-way valve:**
Controls refrigerant flow direction. Closed in cooling mode and open in heating mode. When closed, the heat exchanger functions as a condenser; when open, the heat exchanger functions as an evaporator.
5. **Plate heat exchanger:**
In cooling mode, it can improve super-cooling degree and the super-cooled refrigerant can achieve better heat exchange in indoor side. In heating mode, the refrigerant comes from the plate heat exchanger going to the compressor can enhance the refrigerant enthalpy and improve the heating capacity in low ambient temperature. Refrigerant volume in plate heat exchanger is controlled according to temperature different between plate heat exchanger inlet and outlet.
6. **Solenoid valve SV4:**
Returns oil to the compressor. Opens once the compressor has run for 200 seconds and closes 600 seconds later and then opens for 3 minutes every 20 minutes.
7. **Solenoid valve SV5:**
Enables fast defrosting in heating mode and unloading in cooling mode. During defrosting operation, opens to shorten the refrigerant flow cycle and quicken the defrosting process. In cooling mode, SV5 opens when outdoor ambient temperature is above 40°C or compressor frequency is below 41Hz.
8. **Solenoid valve SV6:**
Allows refrigerant to bypass the expansion valves. Opens in cooling mode when discharge temperature exceeds the limit. Closed in heating mode and standby.
9. **Solenoid valve SV7:**
Allows refrigerant to return directly to the compressor. Opens when indoor air temperature is close to the set temperature to avoid frequent compressor on/off.
10. **Solenoid valve SV8A / SV8B:**
Allows refrigerant from plate heat exchanger inject directly to the compressor. SV8A opens when compressor A startup and closes when compressor A stop. SV8B delays opening when compressor B startup and closes when compressor B stop.
11. **Solenoid valve SV9:**
Balances compressor B pressure. Opens before compressor B startup and closed after compressor B running for 15 seconds. Opens after compressor B stops 10s and keep opening 60s.
12. **High and low pressure switches:**
Regulate system pressure. When system pressure rises above the upper limit or falls below the lower limit, the high or low pressure switches turn off, stopping the compressor. After 10 minutes, the compressor restarts.

5 Wiring Diagrams

8-28HP

Figure 2-5.1: 8-28HP wiring diagram

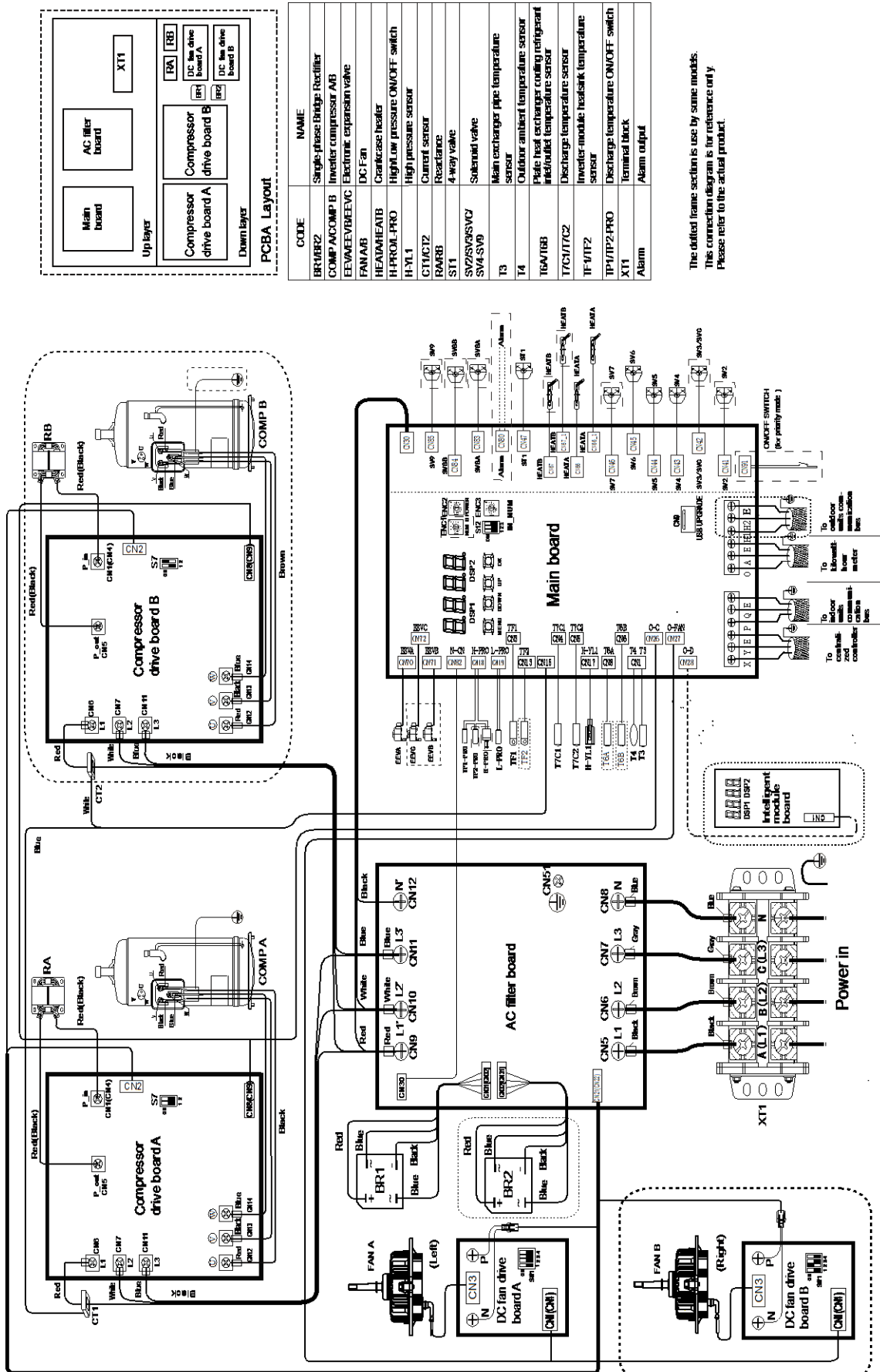

MDV6 VRF 50Hz

30-32HP



Figure 2-5.2: 30-32HP wiring diagram

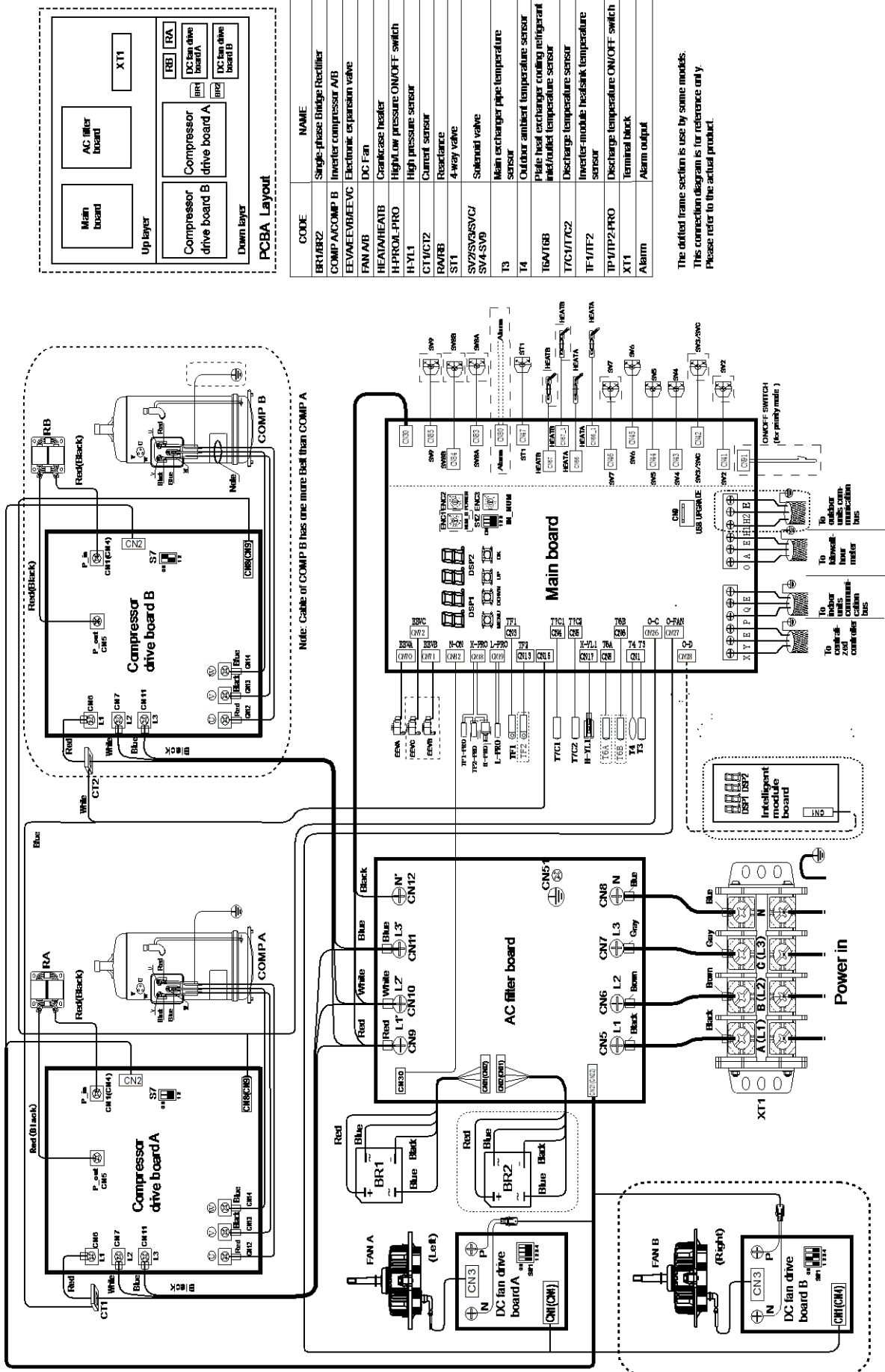

6 Electrical Characteristics

Table 2-6.1: Outdoor unit electrical characteristics

Model				Power Supply ¹						Compressor			OFM	
Capacity	Modules			Hz	Volts	Min.	Max.	MCA ²	TOCA ³	MFA ⁴	MSC ⁵	RLA ⁶	kW	FLA
						volts	volts							
8HP				50	380~415	342	440	24	30.9	32	/	10	0.56	6.3
10HP				50	380~415	342	440	25.2	30.9	32	/	10.6	0.56	6.3
12HP				50	380~415	342	440	26.4	31.5	32	/	15.4	0.56	6.9
14HP				50	380~415	342	440	33.1	40.3	40	/	25.8	0.92	7.3
16HP				50	380~415	342	440	33.1	40.3	40	/	25.8	0.92	7.3
18HP				50	380~415	342	440	40.8	59.3	50	/	14+13	0.56×2	10.1
20HP				50	380~415	342	440	43.9	60.1	50	/	17+16	0.56×2	10.9
22HP				50	380~415	342	440	47.9	60.1	63	/	19+18	0.56×2	10.9
24HP				50	380~415	342	440	48.4	62.3	63	/	17.4+16.6	0.92×2	13.1
26HP				50	380~415	342	440	52.9	62.3	63	/	20+19.8	0.92×2	13.1
28HP				50	380~415	342	440	58.7	64.1	63	/	22+21.8	0.92×2	14.9
30HP				50	380~415	342	440	64.9	72.5	80	/	20+30	0.92×2	14.9
32HP				50	380~415	342	440	66.9	72.5	80	/	22+30	0.92×2	14.9
34HP	12HP	22HP		50	380~415	342	440	74.3	91.6	32+63	/	15.4+19+18	0.56×3	17.8
36HP	14HP	22HP		50	380~415	342	440	81	100.4	40+63	/	25.8+19+18	0.92+	18.2
													0.56×2	
38HP	16HP	22HP		50	380~415	342	440	81	100.4	40+63	/	25.8+19+18	0.92+	18.2
													0.56×2	
40HP	12HP	28HP		50	380~415	342	440	85.1	95.6	32+63	/	15.4+22+21.8	0.56+	21.8
													0.92×2	
42HP	20HP	22HP		50	380~415	342	440	91.8	120.2	50+63	/	17+16+19+18	0.56×4	21.8
44HP	22HP	22HP		50	380~415	342	440	95.8	120.2	63+63	/	19+18+19+18	0.56×4	21.8
46HP	22HP	24HP		50	380~415	342	440	96.3	122.4	63+63	/	19+18+17.4+16.6	0.56×2+	24
													0.92×2	
48HP	22HP	26HP		50	380~415	342	440	100.8	122.4	63+63	/	19+18+20+19.8	0.56×2+	24
													0.92×2	
50HP	22HP	28HP		50	380~415	342	440	106.6	124.2	63+63	/	19+18+22+21.8	0.56×2+	25.8
													0.92×2	
52HP	26HP	26HP		50	380~415	342	440	105.8	124.6	63+63	/	20+19.8+20+19.8	0.92×4	26.2
54HP	26HP	28HP		50	380~415	342	440	111.6	126.4	63+63	/	20+19.8+22+21.8	0.92×4	28
56HP	28HP	28HP		50	380~415	342	440	117.4	128.2	63+63	/	22+21.8+22+21.8	0.92×4	29.8
58HP	28HP	30HP		50	380~415	342	440	123.6	136.6	63+80	/	22+21.8+20+30	0.92×4	29.8
60HP	28HP	32HP		50	380~415	342	440	125.6	136.6	63+80	/	22+21.8+22+30	0.92×4	29.8
62HP	30HP	32HP		50	380~415	342	440	131.8	145	80+80	/	20+30+22+30	0.92×4	29.8
64HP	32HP	32HP		50	380~415	342	440	133.8	145	80+80	/	22+30+22+30	0.92×4	29.8
66HP	12HP	22HP	32HP	50	380~415	342	440	141.2	164.1	32+63+80	/	15.4+19+18+22+30	0.56×3+	32.7
													0.92×2	
68HP	14HP	22HP	32HP	50	380~415	342	440	147.9	172.9	40+63+80	/	25.8+19+18+22+30	0.56×2+	33.1
													0.92×3	
70HP	16HP	22HP	32HP	50	380~415	342	440	147.9	172.9	40+63+80	/	25.8+19+18+22+30	0.56×2+	33.1
													0.92×3	
72HP	12HP	28HP	32HP	50	380~415	342	440	152	168.1	32+63+80	/	15.4+22+21.8+22+30	0.56+	36.7
													0.92×4	
74HP	20HP	22HP	32HP	50	380~415	342	440	158.7	192.7	50+63+80	/	17+16+19+18+22+30	0.56×4+	36.7
													0.92×2	
													0.56×4+	

MDV6 VRF 50Hz



76HP	22HP	22HP	32HP	50	380~415	342	440	162.7	192.7	63+63+80	/	19+18+19+18+22+30	0.92×2	36.7
78HP	22HP	24HP	32HP	50	380~415	342	440	163.2	194.9	63+63+80	/	19+18+17.4+16.6+22+30	0.56×2+	38.9
													0.92×4	
80HP	22HP	26HP	32HP	50	380~415	342	440	167.7	194.9	63+63+80	/	19+18+20+19.8+22+30	0.56×2+	38.9
													0.92×4	
82HP	22HP	28HP	32HP	50	380~415	342	440	173.5	196.7	63+63+80	/	19+18+22+21.8+22+30	0.56×2+	40.7
													0.92×4	
84HP	26HP	26HP	32HP	50	380~415	342	440	172.7	197.1	63+63+80	/	20+19.8+20+19.8+22+30	0.92×6	41.1
86HP	26HP	28HP	32HP	50	380~415	342	440	178.5	198.9	63+63+80	/	20+19.8+22+21.8+22+30	0.92×6	42.9
88HP	28HP	28HP	32HP	50	380~415	342	440	184.3	200.7	63+63+80	/	22+21.8+22+21.8+22+30	0.92×6	44.7
90HP	28HP	30HP	32HP	50	380~415	342	440	190.5	209.1	63+80+80	/	22+21.8+20+30+22+30	0.92×6	44.7
92HP	28HP	32HP	32HP	50	380~415	342	440	192.5	209.1	63+80+80	/	22+21.8+22+30+22+30	0.92×6	44.7
94HP	30HP	32HP	32HP	50	380~415	342	440	198.7	217.5	80+80+80	/	20+30+22+30+22+30	0.92×6	44.7
96HP	32HP	32HP	32HP	50	380~415	342	440	200.7	217.5	80+80+80	/	22+30+22+30+22+30	0.92×6	44.7

Abbreviations:

MCA: Minimum Circuit Amps; TOCA: Total Over-current Amps; MFA: Maximum Fuse Amps; MSC: Maximum Starting Current (A); RLA: Rated Load Amps; FLA: Full Load Amps

Notes:

1. Units are suitable for use on electrical systems where voltage supplied to unit terminals is not below or above listed range limits. Maximum allowable voltage variation between phases is 2%.
2. Select wire size based on the value of MCA.
3. TOCA indicates the total overcurrent amps value of each OC set.
4. MFA is used to select overcurrent circuit breakers and residual-current circuit breakers.
5. MSC indicates the maximum current on compressor start-up in amps.
6. RLA is based on the following conditions: indoor temperature 27°C DB, 19°C WB; outdoor temperature 35°C DB.

7 Functional Components and Safety Devices

Table 2-7.1: 8/10/12/14/16HP functional components and safety devices

Item		8HP	10HP	12HP	14HP	16HP
Compressor	Discharge temperature switch	Off: 115 (±5) °C / On: 75 (±15) °C				
	Compressor top and discharge pipe temperature sensors	90°C = 5kΩ ± 3%				
	Crankcase heater	30W × 2				
Inverter module	Inverter module temperature sensor	90°C = 5kΩ ± 5%				
Fan motor	Safety thermostat	On	115°C			
		Off	-			
System	High pressure switch	Off: 4.4 (±0.1) MPa / On: 3.2 (±0.1) MPa				
	Low pressure switch	Off: 0.05 (±0.05) MPa / On: 0.15 (±0.05) MPa				
	High pressure sensor	Output voltage (V) = 0.8696 × P + 0.5 (where P is the discharge pressure in MPa)				
	Heat exchanger temperature sensor	25°C = 10kΩ				
	Outdoor ambient temperature sensor	25°C = 10kΩ				

Table 2-7.2: 18/20/22/24HP functional components and safety devices

Item		18HP	20HP	22HP	24HP
Compressor	Discharge temperature switch	Off: 115 (±5) °C / On: 75 (±15) °C			
	Compressor top and discharge pipe temperature sensors	90°C = 5kΩ ± 3%			
	Crankcase heater	30W × 4			
Inverter module	Inverter module temperature sensor	90°C = 5kΩ ± 5%			
Fan motor	Safety thermostat	On	115°C		
		Off	-		
System	High pressure switch	Off: 4.4 (±0.1) MPa / On: 3.2 (±0.1) MPa			
	Low pressure switch	Off: 0.05 (±0.05) MPa / On: 0.15 (±0.05) MPa			
	High pressure sensor	Output voltage (V) = 0.8696 × P + 0.5 (where P is the discharge pressure in MPa)			
	Heat exchanger temperature sensor	25°C = 10kΩ			
	Outdoor ambient temperature sensor	25°C = 10kΩ			

Table 2-7.3: 26/28/30/32HP functional components and safety devices

Item		26HP	28HP	30HP	32HP
Compressor	Discharge temperature switch	Off: 115 (±5) °C / On: 75 (±15) °C			
	Compressor top and discharge pipe temperature sensors	90°C = 5kΩ ± 3%			
	Crankcase heater	30W × 4			
Inverter module	Inverter module temperature sensor	90°C = 5kΩ ± 5%			
Fan motor	Safety thermostat	On	115°C		
		Off	-		
System	High pressure switch	Off: 4.4 (±0.1) MPa / On: 3.2 (±0.1) MPa			
	Low pressure switch	Off: 0.05 (±0.05) MPa / On: 0.15 (±0.05) MPa			
	High pressure sensor	Output voltage (V) = 0.8696 × P + 0.5 (where P is the discharge pressure in MPa)			
	Heat exchanger temperature sensor	25°C = 10kΩ			
	Outdoor ambient temperature sensor	25°C = 10kΩ			

8 Capacity Tables

8.1 Cooling Capacity Tables

Table 2-8.1: 8HP cooling capacity

Combination (%) (Capacity index)	Outdoor temperature (°C DB)	Indoor temperature(°C DB/WB)													
		DB:20.8,WB:14		DB:23.3,WB:16		DB:25.8,WB:18		DB:27,WB:19		DB:28.2,WB:20		DB:30.7,WB:22		DB:32,WB:24	
		TC kW	PI kW	TC kW	PI kW	TC kW	PI kW	TC kW	PI kW	TC kW	PI kW	TC kW	PI kW	TC kW	PI kW
130%	-5	22.1	3.42	26.4	4.18	30.6	4.48	31.8	4.66	33.3	4.79	34.1	5.21	35.0	5.24
	-2	22.1	3.42	26.4	4.26	30.6	4.48	31.8	4.69	33.3	4.79	34.1	5.28	35.0	5.30
	0	22.1	3.48	26.4	4.33	30.6	4.64	31.8	4.94	33.3	5.07	34.1	5.34	35.0	5.37
	2	22.1	3.54	26.4	4.34	30.6	4.80	31.8	5.22	33.3	5.13	34.1	5.38	35.0	5.45
	4	22.1	3.62	26.4	4.43	30.6	4.97	31.8	5.24	33.3	5.20	34.1	5.46	35.0	5.55
	6	22.1	3.69	26.4	4.51	30.6	5.15	31.8	5.29	32.9	5.36	33.7	5.55	34.6	5.59
	8	22.1	3.78	26.4	4.62	30.6	5.41	31.8	5.55	32.5	5.53	33.3	5.56	34.1	5.65
	10	22.1	3.86	26.4	4.72	30.6	5.61	31.8	5.73	32.1	5.63	32.9	5.65	33.7	5.81
	12	22.1	3.93	26.4	4.81	30.6	5.72	31.3	5.82	31.8	5.72	32.5	5.74	33.3	5.85
	14	22.1	4.01	26.4	4.90	30.5	5.81	31.0	5.90	31.3	5.81	32.1	5.82	32.9	5.98
	16	22.1	4.07	26.4	5.00	30.1	5.89	30.5	5.98	30.9	5.98	31.7	5.91	32.5	6.07
	18	22.1	4.15	26.4	5.10	29.7	5.98	30.1	6.01	30.5	6.05	31.3	6.11	32.1	6.16
	20	22.1	4.24	26.4	5.43	29.2	6.27	29.7	6.31	30.1	6.34	30.9	6.40	31.7	6.47
	21	22.1	4.36	26.4	5.62	29.1	6.42	29.5	6.45	29.9	6.49	30.7	6.56	31.5	6.61
	23	22.1	4.67	26.4	6.03	28.7	6.71	29.1	6.75	29.4	6.78	30.2	6.85	31.0	6.92
	25	22.1	4.99	26.4	6.45	28.3	7.01	28.6	7.04	29.1	7.09	29.9	7.15	30.7	7.22
	27	22.1	5.33	26.4	6.91	27.9	7.30	28.3	7.35	28.6	7.38	29.4	7.46	30.2	7.54
	29	22.1	5.69	26.4	7.38	27.4	7.59	27.8	7.64	28.3	7.68	29.1	7.76	29.9	7.84
	31	22.1	6.07	26.3	7.81	27.0	7.90	27.4	7.94	27.8	7.98	28.6	8.07	29.4	8.16
	33	22.1	6.47	25.8	8.10	26.6	8.19	27.0	8.24	27.4	8.28	28.3	8.37	29.0	8.46
35	22.1	6.89	25.4	8.40	26.2	8.50	26.6	8.54	27.0	8.59	27.8	8.69	28.6	8.78	
37	22.1	7.34	25.0	8.70	25.8	8.80	26.2	8.85	26.6	8.90	27.4	9.01	28.2	9.11	
39	22.1	7.81	24.6	8.79	25.4	9.09	25.8	9.15	26.2	9.21	27.0	9.31	27.8	9.42	
41	22.1	8.22	24.3	8.88	25.1	9.18	25.6	9.24	25.9	9.29	26.7	9.33	26.7	9.51	
43	22.1	8.43	24.1	8.92	25.0	9.21	25.4	9.28	25.7	9.31	26.2	9.34	26.4	9.53	
45	22.1	8.85	24.0	9.00	24.7	9.29	25.2	9.34	25.3	9.35	25.5	9.38	25.9	9.71	
48	22.1	9.15	23.9	9.29	24.3	9.37	24.8	9.42	25.0	9.45	24.9	9.54	25.3	9.74	
120%	-5	20.4	3.31	24.3	4.00	28.3	4.73	30.2	5.16	31.7	5.38	32.4	5.55	33.1	5.70
	-2	20.4	3.34	24.3	4.05	28.3	4.78	30.2	5.19	31.7	5.45	32.4	5.60	33.1	5.72
	0	20.4	3.37	24.3	4.07	28.3	4.84	30.2	5.21	31.7	5.49	32.4	5.63	33.1	5.73
	2	20.4	3.38	24.3	4.12	28.3	4.87	30.2	5.26	31.7	5.52	32.4	5.68	33.1	5.74
	4	20.4	3.41	24.3	4.17	28.3	4.94	30.2	5.30	31.7	5.59	32.4	5.69	33.1	5.76
	6	20.4	3.45	24.3	4.20	28.3	5.00	30.2	5.36	31.7	5.65	32.4	5.73	33.1	5.78
	8	20.4	3.48	24.3	4.24	28.3	5.07	30.2	5.43	31.7	5.71	32.4	5.75	33.1	5.81
	10	20.4	3.52	24.3	4.30	28.3	5.11	30.2	5.53	31.7	5.71	32.4	5.77	33.1	5.83
	12	20.4	3.59	24.3	4.38	28.3	5.21	30.2	5.63	31.2	5.73	31.9	5.74	32.7	5.87
	14	20.4	3.66	24.3	4.47	28.3	5.31	30.2	5.74	30.8	5.77	31.6	5.83	32.3	5.94
	16	20.4	3.72	24.3	4.56	28.3	5.42	30.1	5.84	30.4	5.85	31.1	5.92	31.9	6.03
	18	20.4	3.79	24.3	4.65	28.3	5.60	29.6	5.98	30.0	6.00	30.7	6.06	31.5	6.12
	20	20.4	3.87	24.3	4.83	28.3	6.03	29.2	6.27	29.6	6.30	30.3	6.35	31.1	6.41
	21	20.4	3.90	24.3	5.00	28.3	6.24	29.0	6.42	29.3	6.44	30.2	6.50	30.9	6.57
	23	20.4	4.17	24.3	5.36	28.3	6.68	28.6	6.70	29.0	6.74	29.7	6.80	30.4	6.86
	25	20.4	4.46	24.3	5.73	27.8	6.97	28.2	7.00	28.5	7.03	29.3	7.10	30.1	7.16
	27	20.4	4.76	24.3	6.13	27.4	7.26	27.8	7.30	28.2	7.33	28.9	7.40	29.6	7.47
	29	20.4	5.08	24.3	6.54	27.0	7.55	27.4	7.59	27.7	7.63	28.4	7.71	29.2	7.77
	31	20.4	5.42	24.3	6.98	26.5	7.85	27.0	7.89	27.4	7.93	28.1	8.01	28.8	8.09
	33	20.4	5.77	24.3	7.45	26.2	8.15	26.5	8.19	26.9	8.23	27.6	8.32	28.3	8.40
35	20.4	6.14	24.3	7.94	25.7	8.44	26.1	8.49	26.5	8.53	27.3	8.62	28.0	8.71	
37	20.4	6.53	24.3	8.46	25.4	8.74	25.7	8.79	26.1	8.83	26.8	8.93	27.5	9.03	
39	20.4	6.95	24.2	8.94	24.9	9.04	25.3	9.09	25.7	9.14	26.5	9.24	27.2	9.33	
41	20.4	7.14	24.0	9.00	24.7	9.10	25.1	9.16	25.5	9.20	26.3	9.27	26.4	9.40	
43	20.4	7.25	23.9	9.06	24.5	9.16	24.9	9.19	25.3	9.24	25.8	9.29	26.0	9.59	
45	20.4	7.33	23.8	9.15	24.3	9.24	24.6	9.28	25.0	9.31	25.3	9.32	25.7	9.80	
48	20.4	7.38	23.6	9.25	24.0	9.32	24.2	9.33	24.8	9.39	24.9	9.42	25.4	9.92	

Abbreviations:

CR: Combination ratio

TC: Total capacity (kW)

PI: Power input (compressor + outdoor fan motor) (kW)

Notes:

1. Shaded cells indicate rating condition.

Table continued on next page ...

Table 2-8.1: 8HP cooling capacity (continued)

Combination (%) (Capacity index)	Outdoor temperature (°C DB)	Indoor temperature(°C DB/WB)													
		DB:20.8,WB:1 4		DB:23.3,WB:1 6		DB:25.8,WB:1 8		DB:27,WB:1 9		DB:28.2,WB:2 0		DB:30.7,WB:2 2		DB:32,WB:2 4	
		TC kW	PI kW	TC kW	PI kW	TC kW	PI kW	TC kW	PI kW	TC kW	PI kW	TC kW	PI kW	TC kW	PI kW
110%	-5	18.7	2.89	22.3	3.59	25.9	4.29	27.7	4.60	29.5	4.95	31.8	5.14	32.5	5.30
	-2	18.7	2.94	22.3	3.64	25.9	4.32	27.7	4.65	29.5	4.99	31.8	5.19	32.5	5.33
	0	18.7	2.97	22.3	3.66	25.9	4.36	27.7	4.68	29.5	5.05	31.8	5.25	32.5	5.39
	2	18.7	3.04	22.3	3.70	25.9	4.43	27.7	4.73	29.5	5.10	31.8	5.32	32.5	5.46
	4	18.7	3.10	22.3	3.74	25.9	4.47	27.7	4.79	29.5	5.18	31.8	5.39	32.5	5.51
	6	18.7	3.13	22.3	3.78	25.9	4.51	27.7	4.86	29.5	5.24	31.8	5.45	32.5	5.60
	8	18.7	3.16	22.3	3.84	25.9	4.56	27.7	4.91	29.5	5.30	31.8	5.49	32.5	5.66
	10	18.7	3.19	22.3	3.89	25.9	4.63	27.7	5.00	29.5	5.38	31.8	5.53	32.5	5.70
	12	18.7	3.26	22.3	3.97	25.9	4.72	27.7	5.10	29.5	5.48	31.4	5.61	32.0	5.78
	14	18.7	3.32	22.3	4.04	25.9	4.81	27.7	5.19	29.5	5.59	31.0	5.65	31.7	5.82
	16	18.7	3.37	22.3	4.12	25.9	4.90	27.7	5.29	29.5	5.70	30.6	5.72	31.2	5.88
	18	18.7	3.44	22.3	4.20	25.9	5.00	27.7	5.44	29.5	5.97	30.2	6.01	30.9	6.07
	20	18.7	3.51	22.3	4.29	25.9	5.29	27.7	5.84	29.1	6.26	29.8	6.31	30.4	6.36
	21	18.7	3.54	22.3	4.41	25.9	5.48	27.7	6.06	28.9	6.41	29.5	6.45	30.2	6.51
	23	18.7	3.71	22.3	4.73	25.9	5.88	27.7	6.50	28.4	6.69	29.2	6.76	29.8	6.82
	25	18.7	3.96	22.3	5.05	25.9	6.28	27.7	6.96	28.1	6.98	28.7	7.05	29.4	7.11
	27	18.7	4.22	22.3	5.40	25.9	6.73	27.3	7.26	27.6	7.28	28.4	7.35	29.0	7.41
	29	18.7	4.50	22.3	5.77	25.9	7.19	26.9	7.55	27.3	7.58	27.9	7.65	28.6	7.72
	31	18.7	4.80	22.3	6.15	25.9	7.67	26.5	7.84	26.8	7.88	27.5	7.94	28.2	8.02
	33	18.7	5.10	22.3	6.56	25.7	8.09	26.1	8.14	26.5	8.17	27.1	8.25	27.8	8.33
35	18.7	5.43	22.3	6.98	25.3	8.38	25.7	8.43	26.0	8.47	26.6	8.55	27.4	8.63	
37	18.7	5.78	22.3	7.44	24.9	8.69	25.3	8.72	25.6	8.77	26.3	8.86	26.9	8.94	
39	18.7	6.14	22.3	7.92	24.5	8.98	24.8	9.03	25.2	9.07	25.8	9.16	26.6	9.25	
41	18.7	6.20	22.3	7.98	24.3	9.05	24.6	9.09	25.0	9.14	25.5	9.23	25.8	9.32	
43	18.7	6.26	22.3	8.09	24.1	9.11	24.5	9.15	24.8	9.20	25.3	9.26	25.4	9.51	
45	18.7	6.47	22.3	8.13	23.9	9.19	24.2	9.26	24.6	9.28	25.0	9.51	25.1	9.73	
48	18.7	6.68	22.3	8.80	23.5	9.23	23.8	9.31	24.3	9.36	24.6	9.53	24.8	9.81	
100%	-5	17.0	2.63	20.3	3.16	23.6	3.77	25.2	4.04	26.8	4.38	30.1	4.99	31.9	5.21
	-2	17.0	2.66	20.3	3.21	23.6	3.81	25.2	4.11	26.8	4.44	30.1	5.05	31.9	5.24
	0	17.0	2.69	20.3	3.24	23.6	3.85	25.2	4.16	26.8	4.48	30.1	5.13	31.9	5.30
	2	17.0	2.74	20.3	3.28	23.6	3.89	25.2	4.22	26.8	4.53	30.1	5.21	31.9	5.38
	4	17.0	2.76	20.3	3.32	23.6	3.95	25.2	4.28	26.8	4.59	30.1	5.26	31.9	5.44
	6	17.0	2.80	20.3	3.38	23.6	4.00	25.2	4.35	26.8	4.65	30.1	5.33	31.9	5.53
	8	17.0	2.85	20.3	3.43	23.6	4.08	25.2	4.40	26.8	4.73	30.1	5.42	31.9	5.62
	10	17.0	2.89	20.3	3.50	23.6	4.14	25.2	4.48	26.8	4.82	30.1	5.51	31.9	5.70
	12	17.0	2.93	20.3	3.57	23.6	4.22	25.2	4.56	26.8	4.91	30.1	5.61	31.4	5.74
	14	17.0	2.99	20.3	3.63	23.6	4.30	25.2	4.65	26.8	5.00	30.1	5.72	31.0	5.81
	16	17.0	3.05	20.3	3.70	23.6	4.39	25.2	4.74	26.8	5.10	30.0	5.79	30.6	5.88
	18	17.0	3.10	20.3	3.77	23.6	4.47	25.2	4.83	26.8	5.20	29.6	5.98	30.2	6.03
	20	17.0	3.16	20.3	3.85	23.6	4.60	25.2	5.08	26.8	5.57	29.2	6.26	29.8	6.32
	21	17.0	3.19	20.3	3.88	23.6	4.77	25.2	5.26	26.8	5.77	29.0	6.41	29.6	6.46
	23	17.0	3.27	20.3	4.14	23.6	5.11	25.2	5.63	26.8	6.18	28.6	6.70	29.2	6.76
	25	17.0	3.49	20.3	4.42	23.6	5.47	25.2	6.04	26.8	6.62	28.2	7.00	28.8	7.05
	27	17.0	3.72	20.3	4.72	23.6	5.84	25.2	6.45	26.8	7.09	27.7	7.29	28.4	7.36
	29	17.0	3.96	20.3	5.03	23.6	6.24	25.2	6.89	26.7	7.53	27.4	7.59	28.0	7.65
	31	17.0	4.22	20.3	5.37	23.6	6.66	25.2	7.36	26.4	7.82	26.9	7.89	27.5	7.95
	33	17.0	4.48	20.3	5.72	23.6	7.10	25.2	7.85	25.9	8.11	26.6	8.18	27.2	8.26
35	17.0	4.76	20.3	6.08	23.6	7.57	25.2	8.37	25.5	8.41	26.1	8.48	26.7	8.55	
37	17.0	5.07	20.3	6.48	23.6	8.07	24.7	8.67	25.1	8.71	25.7	8.79	26.3	8.86	
39	17.0	5.38	20.3	6.88	23.6	8.59	24.4	8.96	24.7	9.00	25.3	9.08	25.9	9.17	
41	17.0	5.63	20.3	7.13	23.6	8.90	24.0	9.02	24.5	9.14	24.9	9.30	25.5	9.36	
43	17.0	5.88	20.3	7.39	23.6	9.07	23.6	9.13	24.3	9.23	25.0	9.36	25.1	9.47	
45	17.0	6.22	20.3	7.72	23.6	9.22	23.1	9.25	24.2	9.40	24.8	9.50	24.6	9.59	
48	17.0	6.49	20.3	7.99	23.6	9.24	22.2	9.36	24.1	9.57	23.3	9.60	24.0	9.68	

Abbreviations:

CR: Combination ratio

TC: Total capacity (kW)

PI: Power input (compressor + outdoor fan motor) (kW)

Notes:

1. Shaded cells indicate rating condition.

Table continued on next page ...

Table 2-8.1: 8HP cooling capacity (continued)

Combination (%) (Capacity index)	Outdoor temperature (°C DB)	Indoor temperature(°C DB/WB)													
		DB:20.8,WB:14		DB:23.3,WB:16		DB:25.8,WB:18		DB:27,WB:19		DB:28.2,WB:20		DB:30.7,WB:22		DB:32,WB:24	
		TC kW	PI kW	TC kW	PI kW	TC kW	PI kW	TC kW	PI kW	TC kW	PI kW	TC kW	PI kW	TC kW	PI kW
90%	-5	15.3	2.32	18.3	2.79	21.2	3.29	22.7	3.59	24.1	3.82	27.1	4.39	30.1	5.03
	-2	15.3	2.35	18.3	2.82	21.2	3.33	22.7	3.64	24.1	3.87	27.1	4.43	30.1	5.08
	0	15.3	2.38	18.3	2.85	21.2	3.38	22.7	3.68	24.1	3.92	27.1	4.49	30.1	5.12
	2	15.3	2.42	18.3	2.89	21.2	3.42	22.7	3.74	24.1	3.98	27.1	4.58	30.1	5.19
	4	15.3	2.45	18.3	2.93	21.2	3.48	22.7	3.79	24.1	4.03	27.1	4.65	30.1	5.27
	6	15.3	2.49	18.3	2.99	21.2	3.54	22.7	3.86	24.1	4.10	27.1	4.72	30.1	5.36
	8	15.3	2.54	18.3	3.05	21.2	3.61	22.7	3.91	24.1	4.17	27.1	4.81	30.1	5.41
	10	15.3	2.58	18.3	3.11	21.2	3.68	22.7	3.97	24.1	4.26	27.1	4.87	30.1	5.49
	12	15.3	2.63	18.3	3.17	21.2	3.75	22.7	4.04	24.1	4.34	27.1	4.96	30.1	5.60
	14	15.3	2.67	18.3	3.23	21.2	3.81	22.7	4.12	24.1	4.42	27.1	5.05	30.1	5.70
	16	15.3	2.72	18.3	3.28	21.2	3.89	22.7	4.20	24.1	4.51	27.1	5.16	30.0	5.80
	18	15.3	2.76	18.3	3.35	21.2	3.96	22.7	4.28	24.1	4.60	27.1	5.26	29.6	5.98
	20	15.3	2.82	18.3	3.43	21.2	4.04	22.7	4.37	24.1	4.77	27.1	5.65	29.2	6.26
	21	15.3	2.84	18.3	3.45	21.2	4.11	22.7	4.51	24.1	4.94	27.1	5.86	29.0	6.41
	23	15.3	2.90	18.3	3.59	21.2	4.40	22.7	4.84	24.1	5.30	27.1	6.28	28.5	6.70
	25	15.3	3.06	18.3	3.84	21.2	4.70	22.7	5.18	24.1	5.66	27.1	6.72	28.2	7.00
	27	15.3	3.25	18.3	4.08	21.2	5.02	22.7	5.53	24.1	6.06	27.1	7.20	27.7	7.29
	29	15.3	3.46	18.3	4.35	21.2	5.36	22.7	5.90	24.1	6.48	26.8	7.53	27.4	7.58
	31	15.3	3.68	18.3	4.64	21.2	5.71	22.7	6.30	24.1	6.90	26.4	7.82	26.9	7.89
	33	15.3	3.90	18.3	4.93	21.2	6.09	22.7	6.71	24.1	7.37	26.0	8.12	26.5	8.18
35	15.3	4.15	18.3	5.25	21.2	6.49	22.7	7.15	24.1	7.85	25.6	8.42	26.1	8.48	
37	15.3	4.40	18.3	5.57	21.2	6.90	22.7	7.62	24.1	8.37	25.1	8.71	25.7	8.78	
39	15.3	4.67	18.3	5.93	21.2	7.34	22.7	8.11	24.1	8.91	24.8	9.02	25.3	9.08	
41	15.3	4.83	18.3	6.20	21.2	7.61	22.7	8.33	24.1	8.97	24.6	9.24	25.1	9.30	
43	15.3	5.06	18.3	6.47	21.2	7.88	22.7	8.54	24.1	9.16	24.5	9.36	24.9	9.44	
45	15.3	5.39	18.3	6.79	21.2	8.20	22.7	8.83	24.1	9.41	24.3	9.46	24.5	9.57	
48	15.3	5.69	18.3	7.11	21.2	8.51	22.7	8.94	24.1	9.49	24.1	9.59	23.9	9.70	
80%	-5	13.6	2.05	16.2	2.42	18.8	2.87	20.2	3.05	21.5	3.28	24.1	3.80	26.7	4.33
	-2	13.6	2.08	16.2	2.45	18.8	2.89	20.2	3.10	21.5	3.31	24.1	3.83	26.7	4.37
	0	13.6	2.11	16.2	2.48	18.8	2.93	20.2	3.13	21.5	3.37	24.1	3.89	26.7	4.43
	2	13.6	2.16	16.2	2.52	18.8	2.97	20.2	3.19	21.5	3.43	24.1	3.96	26.7	4.52
	4	13.6	2.19	16.2	2.56	18.8	3.03	20.2	3.27	21.5	3.49	24.1	4.04	26.7	4.58
	6	13.6	2.23	16.2	2.62	18.8	3.07	20.2	3.34	21.5	3.56	24.1	4.10	26.7	4.66
	8	13.6	2.27	16.2	2.68	18.8	3.15	20.2	3.39	21.5	3.64	24.1	4.16	26.7	4.75
	10	13.6	2.29	16.2	2.74	18.8	3.23	20.2	3.48	21.5	3.72	24.1	4.25	26.7	4.80
	12	13.6	2.32	16.2	2.79	18.8	3.28	20.2	3.54	21.5	3.80	24.1	4.33	26.7	4.89
	14	13.6	2.37	16.2	2.84	18.8	3.34	20.2	3.60	21.5	3.87	24.1	4.41	26.7	4.98
	16	13.6	2.40	16.2	2.89	18.8	3.41	20.2	3.67	21.5	3.94	24.1	4.50	26.7	5.07
	18	13.6	2.45	16.2	2.95	18.8	3.48	20.2	3.75	21.5	4.02	24.1	4.59	26.7	5.17
	20	13.6	2.49	16.2	3.00	18.8	3.54	20.2	3.81	21.5	4.10	24.1	4.76	26.7	5.53
	21	13.6	2.52	16.2	3.02	18.8	3.58	20.2	3.86	21.5	4.19	24.1	4.93	26.7	5.73
	23	13.6	2.56	16.2	3.09	18.8	3.75	20.2	4.11	21.5	4.48	24.1	5.28	26.7	6.15
	25	13.6	2.64	16.2	3.28	18.8	4.01	20.2	4.39	21.5	4.78	24.1	5.65	26.7	6.58
	27	13.6	2.81	16.2	3.50	18.8	4.27	20.2	4.68	21.5	5.11	24.1	6.04	26.7	7.04
	29	13.6	2.99	16.2	3.72	18.8	4.55	20.2	4.99	21.5	5.46	24.1	6.44	26.7	7.53
	31	13.6	3.17	16.2	3.96	18.8	4.84	20.2	5.31	21.5	5.82	24.1	6.88	26.3	7.82
	33	13.6	3.37	16.2	4.21	18.8	5.16	20.2	5.66	21.5	6.19	24.1	7.33	25.9	8.11
35	13.6	3.58	16.2	4.48	18.8	5.48	20.2	6.03	21.5	6.60	24.1	7.82	25.5	8.41	
37	13.6	3.79	16.2	4.75	18.8	5.83	20.2	6.42	21.5	7.03	24.1	8.34	25.1	8.70	
39	13.6	4.02	16.2	5.07	18.8	6.21	20.2	6.83	21.5	7.48	24.1	8.88	24.7	9.00	
41	13.6	4.11	16.2	5.11	18.8	6.30	20.2	7.01	21.5	7.62	24.1	9.11	24.5	9.16	
43	13.6	4.23	16.2	5.16	18.8	6.39	20.2	7.13	21.5	7.72	24.1	9.21	24.4	9.26	
45	13.6	4.35	16.2	5.22	18.8	6.51	20.2	7.28	21.5	7.86	24.1	9.31	24.1	9.41	
48	13.6	4.49	16.2	5.25	18.8	6.61	20.2	7.38	21.5	7.92	24.1	9.40	23.9	9.53	

Abbreviations:

CR: Combination ratio

TC: Total capacity (kW)

PI: Power input (compressor + outdoor fan motor) (kW)

Notes:

1. Shaded cells indicate rating condition.

Table continued on next page ...

Table 2-8.1: 8HP cooling capacity (continued)

Combination (%) (Capacity index)	Outdoor temperature (°C DB)	Indoor temperature(°C DB/WB)													
		DB:20.8,WB:14		DB:23.3,WB:16		DB:25.8,WB:18		DB:27,WB:19		DB:28.2,WB:20		DB:30.7,WB:22		DB:32,WB:24	
		TC	PI	TC	PI	TC	PI	TC	PI	TC	PI	TC	PI	TC	PI
70%	-5	11.9	1.83	14.2	2.14	16.5	2.43	17.6	2.61	18.8	2.78	21.1	3.18	23.4	3.66
	-2	11.9	1.84	14.2	2.15	16.5	2.44	17.6	2.66	18.8	2.83	21.1	3.23	23.4	3.71
	0	11.9	1.85	14.2	2.18	16.5	2.49	17.6	2.71	18.8	2.88	21.1	3.30	23.4	3.76
	2	11.9	1.86	14.2	2.19	16.5	2.54	17.6	2.76	18.8	2.93	21.1	3.37	23.4	3.82
	4	11.9	1.89	14.2	2.25	16.5	2.59	17.6	2.81	18.8	3.00	21.1	3.42	23.4	3.91
	6	11.9	1.92	14.2	2.29	16.5	2.66	17.6	2.90	18.8	3.07	21.1	3.48	23.4	3.98
	8	11.9	1.95	14.2	2.35	16.5	2.72	17.6	2.94	18.8	3.13	21.1	3.58	23.4	4.06
	10	11.9	1.99	14.2	2.39	16.5	2.79	17.6	3.00	18.8	3.22	21.1	3.66	23.4	4.11
	12	11.9	2.04	14.2	2.43	16.5	2.84	17.6	3.06	18.8	3.27	21.1	3.72	23.4	4.19
	14	11.9	2.08	14.2	2.47	16.5	2.89	17.6	3.10	18.8	3.33	21.1	3.79	23.4	4.27
	16	11.9	2.11	14.2	2.52	16.5	2.94	17.6	3.17	18.8	3.40	21.1	3.86	23.4	4.34
	18	11.9	2.14	14.2	2.56	16.5	3.00	17.6	3.23	18.8	3.45	21.1	3.94	23.4	4.43
	20	11.9	2.18	14.2	2.61	16.5	3.06	17.6	3.28	18.8	3.52	21.1	4.02	23.4	4.56
	21	11.9	2.20	14.2	2.63	16.5	3.08	17.6	3.32	18.8	3.55	21.1	4.07	23.4	4.72
	23	11.9	2.23	14.2	2.67	16.5	3.15	17.6	3.43	18.8	3.73	21.1	4.37	23.4	5.05
	25	11.9	2.28	14.2	2.79	16.5	3.35	17.6	3.67	18.8	3.98	21.1	4.67	23.4	5.40
	27	11.9	2.41	14.2	2.97	16.5	3.58	17.6	3.90	18.8	4.25	21.1	4.99	23.4	5.78
	29	11.9	2.56	14.2	3.15	16.5	3.80	17.6	4.16	18.8	4.52	21.1	5.31	23.4	6.17
	31	11.9	2.71	14.2	3.34	16.5	4.05	17.6	4.42	18.8	4.82	21.1	5.66	23.4	6.58
	33	11.9	2.88	14.2	3.55	16.5	4.31	17.6	4.71	18.8	5.13	21.1	6.04	23.4	7.02
35	11.9	3.05	14.2	3.77	16.5	4.57	17.6	5.01	18.8	5.46	21.1	6.43	23.4	7.48	
37	11.9	3.22	14.2	3.99	16.5	4.86	17.6	5.31	18.8	5.81	21.1	6.85	23.4	7.97	
39	11.9	3.41	14.2	4.23	16.5	5.16	17.6	5.65	18.8	6.17	21.1	7.28	23.4	8.49	
41	11.9	3.56	14.2	4.38	16.5	5.31	17.6	5.84	18.8	6.36	21.1	7.58	23.4	8.86	
43	11.9	3.85	14.2	4.68	16.5	5.53	17.6	6.15	18.8	6.55	21.1	7.85	23.4	9.14	
45	11.9	3.93	14.2	4.78	16.5	5.64	17.6	6.25	18.8	6.87	21.1	8.28	23.4	9.49	
48	11.9	4.01	14.2	4.81	16.5	5.71	17.6	6.36	18.8	7.06	21.1	8.67	23.4	9.72	
60%	-5	10.2	1.56	12.2	1.81	14.1	2.11	15.1	2.25	16.1	2.43	18.1	2.72	20.1	3.12
	-2	10.2	1.57	12.2	1.84	14.1	2.15	15.1	2.28	16.1	2.45	18.1	2.76	20.1	3.14
	0	10.2	1.59	12.2	1.86	14.1	2.18	15.1	2.31	16.1	2.49	18.1	2.81	20.1	3.19
	2	10.2	1.62	12.2	1.90	14.1	2.22	15.1	2.35	16.1	2.52	18.1	2.86	20.1	3.23
	4	10.2	1.67	12.2	1.94	14.1	2.26	15.1	2.38	16.1	2.56	18.1	2.91	20.1	3.27
	6	10.2	1.68	12.2	1.98	14.1	2.30	15.1	2.43	16.1	2.61	18.1	2.97	20.1	3.35
	8	10.2	1.72	12.2	2.01	14.1	2.34	15.1	2.48	16.1	2.67	18.1	3.02	20.1	3.40
	10	10.2	1.75	12.2	2.05	14.1	2.38	15.1	2.55	16.1	2.72	18.1	3.08	20.1	3.45
	12	10.2	1.78	12.2	2.09	14.1	2.43	15.1	2.59	16.1	2.76	18.1	3.14	20.1	3.51
	14	10.2	1.81	12.2	2.12	14.1	2.46	15.1	2.64	16.1	2.82	18.1	3.19	20.1	3.58
	16	10.2	1.83	12.2	2.15	14.1	2.50	15.1	2.69	16.1	2.87	18.1	3.25	20.1	3.64
	18	10.2	1.86	12.2	2.19	14.1	2.55	15.1	2.73	16.1	2.92	18.1	3.31	20.1	3.71
	20	10.2	1.88	12.2	2.23	14.1	2.59	15.1	2.79	16.1	2.98	18.1	3.37	20.1	3.79
	21	10.2	1.91	12.2	2.24	14.1	2.62	15.1	2.81	16.1	3.00	18.1	3.41	20.1	3.82
	23	10.2	1.93	12.2	2.29	14.1	2.66	15.1	2.87	16.1	3.06	18.1	3.54	20.1	4.07
	25	10.2	1.96	12.2	2.32	14.1	2.76	15.1	3.00	16.1	3.25	18.1	3.78	20.1	4.34
	27	10.2	2.04	12.2	2.47	14.1	2.94	15.1	3.20	16.1	3.46	18.1	4.03	20.1	4.64
	29	10.2	2.15	12.2	2.62	14.1	3.14	15.1	3.41	16.1	3.69	18.1	4.30	20.1	4.95
	31	10.2	2.29	12.2	2.78	14.1	3.33	15.1	3.62	16.1	3.93	18.1	4.57	20.1	5.27
	33	10.2	2.41	12.2	2.94	14.1	3.53	15.1	3.85	16.1	4.17	18.1	4.86	20.1	5.62
35	10.2	2.56	12.2	3.13	14.1	3.75	15.1	4.08	16.1	4.43	18.1	5.18	20.1	5.98	
37	10.2	2.71	12.2	3.31	14.1	3.97	15.1	4.33	16.1	4.70	18.1	5.51	20.1	6.36	
39	10.2	2.85	12.2	3.50	14.1	4.21	15.1	4.59	16.1	5.00	18.1	5.84	20.1	6.77	
41	10.2	2.95	12.2	3.65	14.1	4.36	15.1	4.78	16.1	5.18	18.1	6.12	20.1	7.08	
43	10.2	3.04	12.2	3.80	14.1	4.51	15.1	4.92	16.1	5.36	18.1	6.38	20.1	7.38	
45	10.2	3.18	12.2	3.99	14.1	4.70	15.1	5.10	16.1	5.63	18.1	6.66	20.1	7.79	
48	10.2	3.30	12.2	4.17	14.1	4.86	15.1	5.23	16.1	5.84	18.1	6.90	20.1	8.17	

Abbreviations:

CR: Combination ratio

TC: Total capacity (kW)

PI: Power input (compressor + outdoor fan motor) (kW)

Notes:

Shaded cells indicate rating condition.

Table continued on next page ...

Table 2-8.1: 8HP cooling capacity (continued)

Combination (%) (Capacity index)	Outdoor temperature (°C DB)	Indoor temperature(°C DB/WB)													
		DB:20.8,WB:14		DB:23.3,WB:16		DB:25.8,WB:18		DB:27,WB:19		DB:28.2,WB:20		DB:30.7,WB:22		DB:32,WB:24	
		TC kW	PI kW	TC kW	PI kW	TC kW	PI kW	TC kW	PI kW	TC kW	PI kW	TC kW	PI kW	TC kW	PI kW
50%	-5	8.5	1.35	10.2	1.57	11.8	1.80	12.6	1.88	13.4	1.99	15.0	2.26	16.7	2.44
	-2	8.5	1.36	10.2	1.60	11.8	1.82	12.6	1.91	13.4	2.02	15.0	2.29	16.7	2.47
	0	8.5	1.39	10.2	1.62	11.8	1.85	12.6	1.94	13.4	2.05	15.0	2.33	16.7	2.51
	2	8.5	1.41	10.2	1.64	11.8	1.88	12.6	1.97	13.4	2.08	15.0	2.34	16.7	2.56
	4	8.5	1.42	10.2	1.67	11.8	1.90	12.6	1.99	13.4	2.12	15.0	2.40	16.7	2.63
	6	8.5	1.45	10.2	1.70	11.8	1.93	12.6	2.03	13.4	2.16	15.0	2.43	16.7	2.70
	8	8.5	1.48	10.2	1.73	11.8	1.97	12.6	2.08	13.4	2.19	15.0	2.47	16.7	2.79
	10	8.5	1.51	10.2	1.75	11.8	2.00	12.6	2.11	13.4	2.26	15.0	2.54	16.7	2.83
	12	8.5	1.52	10.2	1.77	11.8	2.03	12.6	2.15	13.4	2.30	15.0	2.58	16.7	2.88
	14	8.5	1.55	10.2	1.79	11.8	2.05	12.6	2.20	13.4	2.34	15.0	2.63	16.7	2.93
	16	8.5	1.57	10.2	1.82	11.8	2.09	12.6	2.23	13.4	2.37	15.0	2.67	16.7	2.98
	18	8.5	1.59	10.2	1.85	11.8	2.12	12.6	2.27	13.4	2.41	15.0	2.72	16.7	3.03
	20	8.5	1.61	10.2	1.87	11.8	2.15	12.6	2.30	13.4	2.46	15.0	2.76	16.7	3.09
	21	8.5	1.62	10.2	1.90	11.8	2.18	12.6	2.32	13.4	2.48	15.0	2.80	16.7	3.13
	23	8.5	1.65	10.2	1.92	11.8	2.21	12.6	2.37	13.4	2.53	15.0	2.84	16.7	3.19
	25	8.5	1.67	10.2	1.95	11.8	2.26	12.6	2.41	13.4	2.61	15.0	2.99	16.7	3.41
	27	8.5	1.70	10.2	2.03	11.8	2.38	12.6	2.57	13.4	2.76	15.0	3.18	16.7	3.63
	29	8.5	1.79	10.2	2.14	11.8	2.53	12.6	2.73	13.4	2.94	15.0	3.38	16.7	3.87
	31	8.5	1.90	10.2	2.27	11.8	2.67	12.6	2.90	13.4	3.13	15.0	3.60	16.7	4.12
	33	8.5	2.01	10.2	2.40	11.8	2.84	12.6	3.07	13.4	3.32	15.0	3.82	16.7	4.38
35	8.5	2.12	10.2	2.54	11.8	3.00	12.6	3.25	13.4	3.51	15.0	4.06	16.7	4.65	
37	8.5	2.23	10.2	2.69	11.8	3.18	12.6	3.44	13.4	3.72	15.0	4.31	16.7	4.94	
39	8.5	2.36	10.2	2.83	11.8	3.36	12.6	3.64	13.4	3.95	15.0	4.57	16.7	5.25	
41	8.5	2.46	10.2	2.95	11.8	3.48	12.6	3.81	13.4	4.12	15.0	4.81	16.7	5.49	
43	8.5	2.62	10.2	3.16	11.8	3.61	12.6	3.99	13.4	4.22	15.0	5.06	16.7	5.73	
45	8.5	2.68	10.2	3.24	11.8	3.85	12.6	4.29	13.4	4.40	15.0	5.54	16.7	6.22	
48	8.5	2.73	10.2	3.31	11.8	4.06	12.6	4.58	13.4	4.61	15.0	5.98	16.7	6.69	

Abbreviations:

CR: Combination ratio

TC: Total capacity (kW)

PI: Power input (compressor + outdoor fan motor) (kW)

Notes:

Shaded cells indicate rating condition.

Table 2-8.2: 10HP cooling capacity

Combination (%) (Capacity index)	Outdoor temperature (°C DB)	Indoor temperature(°C DB/WB)													
		DB:20.8,WB:14		DB:23.3,WB:16		DB:25.8,WB:18		DB:27,WB:19		DB:28.2,WB:20		DB:30.7,WB:22		DB:32,WB:24	
		TC	PI	TC	PI	TC	PI	TC	PI	TC	PI	TC	PI	TC	PI
130%	-5	24.6	4.32	29.3	5.27	34.0	5.65	35.3	5.88	37.0	6.05	37.9	6.58	38.9	6.62
	-2	24.6	4.32	29.3	5.38	34.0	5.65	35.3	5.92	37.0	6.05	37.9	6.66	38.9	6.69
	0	24.6	4.39	29.3	5.47	34.0	5.86	35.3	6.24	37.0	6.40	37.9	6.74	38.9	6.78
	2	24.6	4.47	29.3	5.48	34.0	6.06	35.3	6.59	37.0	6.48	37.9	6.79	38.9	6.88
	4	24.6	4.57	29.3	5.59	34.0	6.27	35.3	6.62	37.0	6.56	37.9	6.90	38.9	7.01
	6	24.6	4.66	29.3	5.70	34.0	6.50	35.3	6.68	36.6	6.76	37.4	7.00	38.4	7.06
	8	24.6	4.77	29.3	5.83	34.0	6.83	35.3	7.00	36.1	6.98	37.0	7.03	37.9	7.13
	10	24.6	4.87	29.3	5.96	34.0	7.08	35.3	7.24	35.7	7.11	36.6	7.13	37.5	7.33
	12	24.6	4.96	29.3	6.07	34.0	7.22	34.8	7.35	35.3	7.22	36.1	7.24	37.0	7.38
	14	24.6	5.06	29.3	6.18	33.9	7.33	34.4	7.45	34.8	7.33	35.7	7.35	36.6	7.55
	16	24.6	5.14	29.3	6.31	33.5	7.44	33.9	7.55	34.3	7.55	35.2	7.46	36.1	7.67
	18	24.6	5.24	29.3	6.44	33.0	7.55	33.4	7.59	33.9	7.64	34.8	7.71	35.7	7.78
	20	24.6	5.36	29.3	6.85	32.5	7.92	33.0	7.96	33.4	8.01	34.3	8.08	35.2	8.16
	21	24.6	5.50	29.3	7.10	32.3	8.11	32.8	8.15	33.2	8.19	34.1	8.28	35.0	8.35
	23	24.6	5.90	29.3	7.61	31.9	8.48	32.3	8.52	32.7	8.56	33.6	8.65	34.5	8.73
	25	24.6	6.30	29.3	8.15	31.4	8.85	31.8	8.89	32.3	8.95	33.2	9.03	34.1	9.12
	27	24.6	6.72	29.3	8.72	31.0	9.22	31.4	9.27	31.8	9.32	32.7	9.42	33.6	9.52
	29	24.6	7.18	29.3	9.32	30.5	9.59	30.9	9.64	31.4	9.70	32.3	9.80	33.2	9.90
	31	24.6	7.66	29.2	9.86	30.0	9.97	30.5	10.03	30.9	10.07	31.8	10.19	32.7	10.30
	33	24.6	8.16	28.7	10.23	29.6	10.34	30.0	10.40	30.5	10.46	31.4	10.57	32.2	10.69
35	24.6	8.70	28.2	10.60	29.1	10.73	29.6	10.78	30.0	10.84	30.9	10.97	31.8	11.08	
37	24.6	9.26	27.8	10.98	28.7	11.11	29.1	11.17	29.6	11.24	30.4	11.37	31.3	11.50	
39	24.6	9.86	27.3	11.10	28.2	11.48	28.7	11.55	29.1	11.62	30.0	11.75	30.9	11.90	
41	24.6	10.38	27.0	11.21	27.9	11.59	28.4	11.66	28.8	11.73	29.7	11.78	29.7	12.00	
43	24.6	10.64	26.8	11.26	27.8	11.62	28.3	11.72	28.5	11.75	29.2	11.80	29.4	12.03	
45	24.6	11.17	26.7	11.37	27.5	11.73	28.0	11.79	28.1	11.80	28.4	11.84	28.8	12.26	
48	24.6	11.55	26.6	11.73	27.0	11.83	27.5	11.89	27.7	11.93	27.6	12.05	28.1	12.30	
120%	-5	22.7	4.17	27.0	5.05	31.4	5.98	33.6	6.52	35.2	6.80	36.0	7.01	36.8	7.20
	-2	22.7	4.21	27.0	5.11	31.4	6.04	33.6	6.56	35.2	6.88	36.0	7.07	36.8	7.22
	0	22.7	4.25	27.0	5.14	31.4	6.11	33.6	6.57	35.2	6.94	36.0	7.11	36.8	7.24
	2	22.7	4.26	27.0	5.20	31.4	6.15	33.6	6.64	35.2	6.96	36.0	7.17	36.8	7.25
	4	22.7	4.31	27.0	5.26	31.4	6.23	33.6	6.70	35.2	7.06	36.0	7.18	36.8	7.27
	6	22.7	4.35	27.0	5.30	31.4	6.31	33.6	6.77	35.2	7.13	36.0	7.24	36.8	7.30
	8	22.7	4.39	27.0	5.36	31.4	6.40	33.6	6.86	35.2	7.20	36.0	7.26	36.8	7.33
	10	22.7	4.44	27.0	5.43	31.4	6.45	33.6	6.98	35.2	7.21	36.0	7.28	36.8	7.36
	12	22.7	4.53	27.0	5.53	31.4	6.58	33.6	7.11	34.7	7.24	35.5	7.24	36.3	7.41
	14	22.7	4.62	27.0	5.64	31.4	6.71	33.6	7.25	34.2	7.28	35.1	7.35	35.9	7.50
	16	22.7	4.70	27.0	5.75	31.4	6.84	33.4	7.38	33.8	7.39	34.6	7.48	35.4	7.61
	18	22.7	4.79	27.0	5.87	31.4	7.07	32.9	7.55	33.3	7.58	34.1	7.65	35.0	7.72
	20	22.7	4.89	27.0	6.10	31.4	7.61	32.5	7.92	32.9	7.95	33.7	8.02	34.5	8.09
	21	22.7	4.93	27.0	6.31	31.4	7.88	32.2	8.11	32.6	8.13	33.5	8.21	34.3	8.29
	23	22.7	5.27	27.0	6.77	31.4	8.43	31.8	8.46	32.2	8.51	33.0	8.59	33.8	8.66
	25	22.7	5.63	27.0	7.24	30.9	8.80	31.3	8.83	31.7	8.88	32.6	8.96	33.4	9.05
	27	22.7	6.01	27.0	7.74	30.5	9.16	30.9	9.22	31.3	9.26	32.1	9.34	32.9	9.43
	29	22.7	6.41	27.0	8.26	30.0	9.53	30.4	9.59	30.8	9.63	31.6	9.73	32.5	9.82
	31	22.7	6.84	27.0	8.82	29.5	9.91	30.0	9.96	30.4	10.01	31.2	10.11	32.0	10.21
	33	22.7	7.28	27.0	9.40	29.1	10.29	29.5	10.34	29.9	10.39	30.7	10.50	31.5	10.60
35	22.7	7.75	27.0	10.03	28.6	10.65	29.0	10.71	29.5	10.77	30.3	10.88	31.1	11.00	
37	22.7	8.25	27.0	10.68	28.2	11.04	28.6	11.10	29.0	11.15	29.8	11.27	30.6	11.40	
39	22.7	8.77	26.9	11.28	27.7	11.41	28.1	11.48	28.5	11.54	29.4	11.67	30.2	11.78	
41	22.7	9.02	26.7	11.36	27.5	11.49	27.9	11.56	28.3	11.62	29.2	11.70	29.3	11.87	
43	22.7	9.15	26.5	11.44	27.3	11.56	27.7	11.61	28.1	11.66	28.7	11.73	28.9	12.11	
45	22.7	9.26	26.4	11.55	27.0	11.67	27.4	11.72	27.8	11.75	28.1	11.77	28.6	12.37	
48	22.7	9.32	26.2	11.68	26.7	11.77	26.9	11.78	27.5	11.86	27.7	11.89	28.2	12.52	

Abbreviations:

CR: Combination ratio

TC: Total capacity (kW)

PI: Power input (compressor + outdoor fan motor) (kW)

Notes:

Shaded cells indicate rating condition.

Table continued on next page ...

Table 2-8.2: 10HP cooling capacity (continued)

Combination (%) (Capacity index)	Outdoor temperature (°C DB)	Indoor temperature (°C DB/WB)													
		DB:20.8,WB:1 4		DB:23.3,WB:1 6		DB:25.8,WB:1 8		DB:27,WB:19		DB:28.2,WB:2 0		DB:30.7,WB:2 2		DB:32,WB:24	
		TC kW	PI kW	TC kW	PI kW	TC kW	PI kW	TC kW	PI kW	TC kW	PI kW	TC kW	PI kW	TC kW	PI kW
110%	-5	20.8	3.64	24.8	4.54	28.8	5.41	30.8	5.81	32.8	6.25	35.3	6.49	36.1	6.69
	-2	20.8	3.71	24.8	4.60	28.8	5.46	30.8	5.87	32.8	6.30	35.3	6.56	36.1	6.73
	0	20.8	3.75	24.8	4.62	28.8	5.50	30.8	5.91	32.8	6.37	35.3	6.62	36.1	6.81
	2	20.8	3.83	24.8	4.67	28.8	5.59	30.8	5.97	32.8	6.44	35.3	6.72	36.1	6.90
	4	20.8	3.91	24.8	4.72	28.8	5.64	30.8	6.04	32.8	6.54	35.3	6.81	36.1	6.96
	6	20.8	3.95	24.8	4.77	28.8	5.69	30.8	6.14	32.8	6.61	35.3	6.88	36.1	7.07
	8	20.8	3.98	24.8	4.85	28.8	5.76	30.8	6.20	32.8	6.69	35.3	6.93	36.1	7.14
	10	20.8	4.03	24.8	4.91	28.8	5.84	30.8	6.31	32.8	6.80	35.3	6.98	36.1	7.20
	12	20.8	4.12	24.8	5.01	28.8	5.96	30.8	6.44	32.8	6.92	34.9	7.08	35.6	7.30
	14	20.8	4.19	24.8	5.10	28.8	6.07	30.8	6.55	32.8	7.05	34.4	7.14	35.2	7.35
	16	20.8	4.26	24.8	5.20	28.8	6.18	30.8	6.68	32.8	7.19	34.0	7.22	34.7	7.43
	18	20.8	4.35	24.8	5.30	28.8	6.31	30.8	6.87	32.8	7.54	33.5	7.59	34.3	7.66
	20	20.8	4.43	24.8	5.41	28.8	6.68	30.8	7.38	32.3	7.91	33.1	7.96	33.8	8.03
	21	20.8	4.47	24.8	5.57	28.8	6.92	30.8	7.65	32.1	8.09	32.8	8.15	33.6	8.22
	23	20.8	4.69	24.8	5.97	28.8	7.42	30.8	8.21	31.6	8.45	32.4	8.53	33.1	8.61
	25	20.8	5.00	24.8	6.38	28.8	7.93	30.8	8.79	31.2	8.82	31.9	8.90	32.7	8.98
	27	20.8	5.33	24.8	6.82	28.8	8.49	30.3	9.16	30.7	9.19	31.5	9.27	32.2	9.36
	29	20.8	5.68	24.8	7.28	28.8	9.07	29.9	9.53	30.3	9.57	31.0	9.66	31.8	9.74
	31	20.8	6.05	24.8	7.76	28.8	9.69	29.4	9.90	29.8	9.94	30.6	10.03	31.3	10.13
	33	20.8	6.44	24.8	8.28	28.6	10.21	29.0	10.27	29.4	10.31	30.1	10.41	30.9	10.51
35	20.8	6.85	24.8	8.82	28.1	10.58	28.5	10.64	28.9	10.70	29.6	10.80	30.4	10.90	
37	20.8	7.29	24.8	9.39	27.7	10.97	28.1	11.01	28.4	11.07	29.2	11.18	29.9	11.28	
39	20.8	7.75	24.8	10.00	27.2	11.34	27.6	11.40	28.0	11.45	28.7	11.57	29.5	11.68	
41	20.8	7.83	24.8	10.08	27.0	11.42	27.4	11.48	27.8	11.53	28.3	11.65	28.6	11.76	
43	20.8	7.91	24.8	10.21	26.8	11.50	27.2	11.56	27.6	11.61	28.1	11.69	28.2	12.00	
45	20.8	8.17	24.8	10.27	26.5	11.61	26.9	11.70	27.3	11.72	27.8	12.01	27.9	12.28	
48	20.8	8.43	24.8	11.11	26.1	11.66	26.5	11.75	27.0	11.82	27.3	12.03	27.6	12.39	
100%	-5	18.9	3.32	22.5	4.00	26.2	4.76	28.0	5.09	29.8	5.53	33.5	6.30	35.4	6.57
	-2	18.9	3.36	22.5	4.05	26.2	4.81	28.0	5.19	29.8	5.60	33.5	6.37	35.4	6.62
	0	18.9	3.39	22.5	4.09	26.2	4.86	28.0	5.25	29.8	5.66	33.5	6.48	35.4	6.69
	2	18.9	3.46	22.5	4.15	26.2	4.92	28.0	5.32	29.8	5.72	33.5	6.57	35.4	6.80
	4	18.9	3.49	22.5	4.19	26.2	4.99	28.0	5.40	29.8	5.79	33.5	6.64	35.4	6.87
	6	18.9	3.54	22.5	4.27	26.2	5.05	28.0	5.50	29.8	5.88	33.5	6.73	35.4	6.98
	8	18.9	3.60	22.5	4.33	26.2	5.15	28.0	5.56	29.8	5.97	33.5	6.84	35.4	7.09
	10	18.9	3.65	22.5	4.42	26.2	5.23	28.0	5.66	29.8	6.08	33.5	6.95	35.4	7.19
	12	18.9	3.70	22.5	4.50	26.2	5.33	28.0	5.76	29.8	6.20	33.5	7.08	34.9	7.25
	14	18.9	3.77	22.5	4.59	26.2	5.43	28.0	5.87	29.8	6.31	33.5	7.22	34.5	7.34
	16	18.9	3.85	22.5	4.67	26.2	5.54	28.0	5.98	29.8	6.44	33.3	7.31	34.0	7.42
	18	18.9	3.92	22.5	4.76	26.2	5.64	28.0	6.10	29.8	6.57	32.9	7.55	33.6	7.61
	20	18.9	3.99	22.5	4.86	26.2	5.81	28.0	6.41	29.8	7.04	32.4	7.91	33.1	7.98
	21	18.9	4.03	22.5	4.90	26.2	6.03	28.0	6.64	29.8	7.28	32.2	8.09	32.9	8.16
	23	18.9	4.13	22.5	5.23	26.2	6.45	28.0	7.11	29.8	7.81	31.8	8.46	32.4	8.53
	25	18.9	4.40	22.5	5.58	26.2	6.91	28.0	7.62	29.8	8.36	31.3	8.83	32.0	8.90
	27	18.9	4.70	22.5	5.95	26.2	7.38	28.0	8.15	29.8	8.95	30.8	9.20	31.5	9.29
	29	18.9	5.00	22.5	6.35	26.2	7.88	28.0	8.70	29.7	9.50	30.4	9.59	31.1	9.66
	31	18.9	5.33	22.5	6.78	26.2	8.40	28.0	9.29	29.3	9.87	29.9	9.96	30.6	10.04
	33	18.9	5.66	22.5	7.22	26.2	8.96	28.0	9.91	28.8	10.24	29.5	10.33	30.2	10.43
35	18.9	6.01	22.5	7.68	26.2	9.56	28.0	10.57	28.3	10.61	29.0	10.71	29.7	10.80	
37	18.9	6.40	22.5	8.18	26.2	10.19	27.5	10.94	27.9	11.00	28.6	11.10	29.2	11.18	
39	18.9	6.79	22.5	8.69	26.2	10.84	27.1	11.31	27.4	11.37	28.1	11.47	28.8	11.58	
41	18.9	7.11	22.5	9.01	26.2	11.24	26.7	11.39	27.2	11.54	27.6	11.74	28.4	11.82	
43	18.9	7.43	22.5	9.32	26.2	11.45	26.3	11.52	27.0	11.65	27.8	11.81	27.9	11.95	
45	18.9	7.85	22.5	9.75	26.2	11.64	25.7	11.68	26.9	11.87	27.5	12.00	27.3	12.11	
48	18.9	8.20	22.5	10.09	26.2	11.66	24.6	11.81	26.8	12.08	25.9	12.12	26.7	12.22	

Abbreviations:

CR: Combination ratio

TC: Total capacity (kW)

PI: Power input (compressor + outdoor fan motor) (kW)

Notes:

Shaded cells indicate rating condition.

Table continued on next page ...

Table 2-8.2: 10HP cooling capacity (continued)

Combination (%) (Capacity index)	Outdoor temperature (°C DB)	Indoor temperature(°C DB/WB)													
		DB:20.8,WB:14		DB:23.3,WB:16		DB:25.8,WB:18		DB:27,WB:19		DB:28.2,WB:20		DB:30.7,WB:22		DB:32,WB:24	
		TC kW	PI kW	TC kW	PI kW	TC kW	PI kW	TC kW	PI kW	TC kW	PI kW	TC kW	PI kW	TC kW	PI kW
90%	-5	17.0	2.94	20.3	3.52	23.6	4.15	25.2	4.53	26.8	4.82	30.1	5.55	33.4	6.35
	-2	17.0	2.96	20.3	3.56	23.6	4.21	25.2	4.60	26.8	4.88	30.1	5.60	33.4	6.41
	0	17.0	3.01	20.3	3.60	23.6	4.27	25.2	4.65	26.8	4.94	30.1	5.66	33.4	6.46
	2	17.0	3.05	20.3	3.65	23.6	4.32	25.2	4.72	26.8	5.02	30.1	5.78	33.4	6.56
	4	17.0	3.10	20.3	3.70	23.6	4.39	25.2	4.79	26.8	5.08	30.1	5.87	33.4	6.65
	6	17.0	3.14	20.3	3.78	23.6	4.47	25.2	4.88	26.8	5.17	30.1	5.96	33.4	6.76
	8	17.0	3.20	20.3	3.85	23.6	4.56	25.2	4.94	26.8	5.26	30.1	6.07	33.4	6.83
	10	17.0	3.26	20.3	3.93	23.6	4.64	25.2	5.01	26.8	5.38	30.1	6.15	33.4	6.94
	12	17.0	3.32	20.3	4.00	23.6	4.73	25.2	5.10	26.8	5.48	30.1	6.27	33.4	7.07
	14	17.0	3.38	20.3	4.07	23.6	4.81	25.2	5.20	26.8	5.58	30.1	6.38	33.4	7.19
	16	17.0	3.43	20.3	4.15	23.6	4.91	25.2	5.30	26.8	5.70	30.1	6.51	33.3	7.32
	18	17.0	3.49	20.3	4.23	23.6	5.00	25.2	5.40	26.8	5.81	30.1	6.64	32.9	7.55
	20	17.0	3.56	20.3	4.33	23.6	5.10	25.2	5.51	26.8	6.03	30.1	7.14	32.4	7.91
	21	17.0	3.59	20.3	4.36	23.6	5.18	25.2	5.70	26.8	6.24	30.1	7.39	32.2	8.09
	23	17.0	3.66	20.3	4.53	23.6	5.56	25.2	6.11	26.8	6.69	30.1	7.93	31.7	8.46
	25	17.0	3.86	20.3	4.84	23.6	5.94	25.2	6.54	26.8	7.15	30.1	8.49	31.3	8.83
	27	17.0	4.10	20.3	5.16	23.6	6.34	25.2	6.98	26.8	7.65	30.1	9.09	30.8	9.20
	29	17.0	4.37	20.3	5.50	23.6	6.77	25.2	7.45	26.8	8.18	29.8	9.50	30.4	9.57
	31	17.0	4.64	20.3	5.85	23.6	7.21	25.2	7.95	26.8	8.72	29.3	9.87	29.9	9.96
	33	17.0	4.93	20.3	6.23	23.6	7.69	25.2	8.47	26.8	9.30	28.9	10.26	29.5	10.33
35	17.0	5.24	20.3	6.62	23.6	8.19	25.2	9.03	26.8	9.91	28.4	10.63	29.0	10.71	
37	17.0	5.56	20.3	7.04	23.6	8.72	25.2	9.62	26.8	10.57	27.9	11.00	28.6	11.08	
39	17.0	5.90	20.3	7.49	23.6	9.27	25.2	10.24	26.8	11.25	27.5	11.38	28.1	11.47	
41	17.0	6.10	20.3	7.83	23.6	9.61	25.2	10.51	26.8	11.32	27.3	11.67	27.9	11.74	
43	17.0	6.39	20.3	8.17	23.6	9.95	25.2	10.78	26.8	11.56	27.2	11.82	27.7	11.92	
45	17.0	6.80	20.3	8.58	23.6	10.36	25.2	11.15	26.8	11.88	27.0	11.95	27.2	12.08	
48	17.0	7.18	20.3	8.97	23.6	10.75	25.2	11.29	26.8	11.99	26.8	12.11	26.5	12.24	
80%	-5	15.1	2.59	18.0	3.06	20.9	3.62	22.4	3.85	23.9	4.15	26.8	4.79	29.7	5.47
	-2	15.1	2.62	18.0	3.10	20.9	3.65	22.4	3.91	23.9	4.18	26.8	4.84	29.7	5.52
	0	15.1	2.67	18.0	3.13	20.9	3.70	22.4	3.96	23.9	4.26	26.8	4.91	29.7	5.60
	2	15.1	2.72	18.0	3.18	20.9	3.75	22.4	4.03	23.9	4.34	26.8	5.01	29.7	5.71
	4	15.1	2.77	18.0	3.23	20.9	3.82	22.4	4.12	23.9	4.41	26.8	5.10	29.7	5.78
	6	15.1	2.81	18.0	3.31	20.9	3.88	22.4	4.21	23.9	4.50	26.8	5.17	29.7	5.88
	8	15.1	2.87	18.0	3.39	20.9	3.97	22.4	4.28	23.9	4.59	26.8	5.25	29.7	5.99
	10	15.1	2.89	18.0	3.46	20.9	4.07	22.4	4.39	23.9	4.70	26.8	5.37	29.7	6.05
	12	15.1	2.93	18.0	3.52	20.9	4.15	22.4	4.47	23.9	4.80	26.8	5.47	29.7	6.17
	14	15.1	2.99	18.0	3.59	20.9	4.22	22.4	4.54	23.9	4.89	26.8	5.57	29.7	6.28
	16	15.1	3.03	18.0	3.65	20.9	4.30	22.4	4.63	23.9	4.97	26.8	5.68	29.7	6.40
	18	15.1	3.09	18.0	3.72	20.9	4.39	22.4	4.73	23.9	5.07	26.8	5.80	29.7	6.52
	20	15.1	3.15	18.0	3.79	20.9	4.47	22.4	4.82	23.9	5.17	26.8	6.01	29.7	6.98
	21	15.1	3.18	18.0	3.82	20.9	4.52	22.4	4.87	23.9	5.29	26.8	6.23	29.7	7.24
	23	15.1	3.23	18.0	3.90	20.9	4.73	22.4	5.19	23.9	5.66	26.8	6.67	29.7	7.76
	25	15.1	3.33	18.0	4.15	20.9	5.06	22.4	5.54	23.9	6.04	26.8	7.14	29.7	8.31
	27	15.1	3.55	18.0	4.42	20.9	5.39	22.4	5.91	23.9	6.45	26.8	7.62	29.7	8.89
	29	15.1	3.78	18.0	4.70	20.9	5.74	22.4	6.30	23.9	6.90	26.8	8.13	29.7	9.50
	31	15.1	4.00	18.0	5.00	20.9	6.11	22.4	6.71	23.9	7.35	26.8	8.69	29.2	9.87
	33	15.1	4.26	18.0	5.31	20.9	6.51	22.4	7.15	23.9	7.82	26.8	9.26	28.8	10.24
35	15.1	4.52	18.0	5.66	20.9	6.92	22.4	7.61	23.9	8.33	26.8	9.87	28.3	10.61	
37	15.1	4.79	18.0	6.00	20.9	7.37	22.4	8.11	23.9	8.88	26.8	10.53	27.9	10.98	
39	15.1	5.07	18.0	6.40	20.9	7.84	22.4	8.62	23.9	9.45	26.8	11.21	27.4	11.37	
41	15.1	5.19	18.0	6.45	20.9	7.95	22.4	8.85	23.9	9.62	26.8	11.50	27.2	11.57	
43	15.1	5.34	18.0	6.51	20.9	8.06	22.4	9.00	23.9	9.75	26.8	11.63	27.1	11.69	
45	15.1	5.49	18.0	6.59	20.9	8.22	22.4	9.19	23.9	9.92	26.8	11.76	26.7	11.88	
48	15.1	5.67	18.0	6.63	20.9	8.35	22.4	9.31	23.9	10.00	26.8	11.87	26.5	12.03	

Abbreviations:

CR: Combination ratio

TC: Total capacity (kW)

PI: Power input (compressor + outdoor fan motor) (kW)

Notes:

Shaded cells indicate rating condition.

Table continued on next page ...

Table 2-8.2: 10HP cooling capacity (continued)

Combination (%) (Capacity index)	Outdoor temperature (°C DB)	Indoor temperature(°C DB/WB)													
		DB:20.8,WB:14		DB:23.3,WB:16		DB:25.8,WB:18		DB:27,WB:19		DB:28.2,WB:20		DB:30.7,WB:22		DB:32,WB:24	
		TC kW	PI kW	TC kW	PI kW	TC kW	PI kW	TC kW	PI kW	TC kW	PI kW	TC kW	PI kW	TC kW	PI kW
70%	-5	13.2	2.31	15.8	2.71	18.3	3.07	19.6	3.29	20.9	3.51	23.4	4.02	26.0	4.62
	-2	13.2	2.33	15.8	2.72	18.3	3.09	19.6	3.35	20.9	3.57	23.4	4.08	26.0	4.68
	0	13.2	2.34	15.8	2.76	18.3	3.15	19.6	3.42	20.9	3.64	23.4	4.16	26.0	4.74
	2	13.2	2.35	15.8	2.77	18.3	3.20	19.6	3.48	20.9	3.70	23.4	4.25	26.0	4.82
	4	13.2	2.38	15.8	2.84	18.3	3.27	19.6	3.54	20.9	3.78	23.4	4.32	26.0	4.93
	6	13.2	2.42	15.8	2.89	18.3	3.35	19.6	3.66	20.9	3.87	23.4	4.40	26.0	5.03
	8	13.2	2.47	15.8	2.97	18.3	3.43	19.6	3.71	20.9	3.95	23.4	4.52	26.0	5.12
	10	13.2	2.52	15.8	3.02	18.3	3.52	19.6	3.79	20.9	4.06	23.4	4.62	26.0	5.19
	12	13.2	2.58	15.8	3.06	18.3	3.59	19.6	3.86	20.9	4.13	23.4	4.70	26.0	5.29
	14	13.2	2.62	15.8	3.12	18.3	3.65	19.6	3.92	20.9	4.20	23.4	4.79	26.0	5.39
	16	13.2	2.66	15.8	3.18	18.3	3.72	19.6	4.00	20.9	4.29	23.4	4.87	26.0	5.48
	18	13.2	2.71	15.8	3.23	18.3	3.79	19.6	4.07	20.9	4.36	23.4	4.97	26.0	5.60
	20	13.2	2.75	15.8	3.29	18.3	3.86	19.6	4.15	20.9	4.44	23.4	5.07	26.0	5.76
	21	13.2	2.78	15.8	3.32	18.3	3.89	19.6	4.19	20.9	4.49	23.4	5.14	26.0	5.95
	23	13.2	2.82	15.8	3.38	18.3	3.97	19.6	4.33	20.9	4.72	23.4	5.51	26.0	6.38
	25	13.2	2.88	15.8	3.52	18.3	4.23	19.6	4.63	20.9	5.03	23.4	5.90	26.0	6.82
	27	13.2	3.05	15.8	3.75	18.3	4.52	19.6	4.93	20.9	5.37	23.4	6.30	26.0	7.29
	29	13.2	3.23	15.8	3.97	18.3	4.80	19.6	5.26	20.9	5.71	23.4	6.71	26.0	7.79
	31	13.2	3.42	15.8	4.22	18.3	5.11	19.6	5.58	20.9	6.08	23.4	7.15	26.0	8.31
	33	13.2	3.63	15.8	4.49	18.3	5.44	19.6	5.94	20.9	6.48	23.4	7.62	26.0	8.86
35	13.2	3.85	15.8	4.76	18.3	5.77	19.6	6.33	20.9	6.90	23.4	8.12	26.0	9.44	
37	13.2	4.06	15.8	5.04	18.3	6.14	19.6	6.71	20.9	7.34	23.4	8.65	26.0	10.06	
39	13.2	4.30	15.8	5.34	18.3	6.51	19.6	7.14	20.9	7.79	23.4	9.19	26.0	10.71	
41	13.2	4.49	15.8	5.53	18.3	6.70	19.6	7.37	20.9	8.03	23.4	9.57	26.0	11.19	
43	13.2	4.86	15.8	5.91	18.3	6.98	19.6	7.77	20.9	8.27	23.4	9.92	26.0	11.54	
45	13.2	4.97	15.8	6.04	18.3	7.12	19.6	7.90	20.9	8.68	23.4	10.45	26.0	11.98	
48	13.2	5.06	15.8	6.07	18.3	7.21	19.6	8.03	20.9	8.92	23.4	10.94	26.0	12.27	
60%	-5	11.3	1.97	13.5	2.28	15.7	2.66	16.8	2.84	17.9	3.06	20.1	3.44	22.3	3.94
	-2	11.3	1.98	13.5	2.32	15.7	2.71	16.8	2.88	17.9	3.09	20.1	3.49	22.3	3.97
	0	11.3	2.01	13.5	2.35	15.7	2.75	16.8	2.91	17.9	3.15	20.1	3.54	22.3	4.02
	2	11.3	2.05	13.5	2.40	15.7	2.80	16.8	2.97	17.9	3.19	20.1	3.61	22.3	4.07
	4	11.3	2.10	13.5	2.45	15.7	2.85	16.8	3.01	17.9	3.23	20.1	3.67	22.3	4.13
	6	11.3	2.12	13.5	2.50	15.7	2.91	16.8	3.07	17.9	3.30	20.1	3.74	22.3	4.23
	8	11.3	2.17	13.5	2.54	15.7	2.96	16.8	3.13	17.9	3.37	20.1	3.82	22.3	4.30
	10	11.3	2.21	13.5	2.59	15.7	3.01	16.8	3.22	17.9	3.43	20.1	3.89	22.3	4.36
	12	11.3	2.25	13.5	2.63	15.7	3.06	16.8	3.28	17.9	3.49	20.1	3.96	22.3	4.43
	14	11.3	2.28	13.5	2.68	15.7	3.11	16.8	3.33	17.9	3.56	20.1	4.03	22.3	4.52
	16	11.3	2.31	13.5	2.72	15.7	3.16	16.8	3.39	17.9	3.62	20.1	4.10	22.3	4.60
	18	11.3	2.35	13.5	2.76	15.7	3.22	16.8	3.45	17.9	3.69	20.1	4.17	22.3	4.69
	20	11.3	2.38	13.5	2.82	15.7	3.28	16.8	3.52	17.9	3.76	20.1	4.26	22.3	4.79
	21	11.3	2.41	13.5	2.83	15.7	3.30	16.8	3.55	17.9	3.79	20.1	4.30	22.3	4.83
	23	11.3	2.44	13.5	2.89	15.7	3.36	16.8	3.62	17.9	3.86	20.1	4.47	22.3	5.14
	25	11.3	2.48	13.5	2.93	15.7	3.49	16.8	3.79	17.9	4.10	20.1	4.77	22.3	5.48
	27	11.3	2.58	13.5	3.12	15.7	3.72	16.8	4.05	17.9	4.37	20.1	5.09	22.3	5.85
	29	11.3	2.72	13.5	3.30	15.7	3.96	16.8	4.30	17.9	4.66	20.1	5.43	22.3	6.25
	31	11.3	2.89	13.5	3.50	15.7	4.20	16.8	4.57	17.9	4.96	20.1	5.77	22.3	6.65
	33	11.3	3.05	13.5	3.72	15.7	4.46	16.8	4.86	17.9	5.27	20.1	6.14	22.3	7.09
35	11.3	3.23	13.5	3.95	15.7	4.73	16.8	5.16	17.9	5.60	20.1	6.54	22.3	7.55	
37	11.3	3.42	13.5	4.17	15.7	5.01	16.8	5.47	17.9	5.94	20.1	6.95	22.3	8.03	
39	11.3	3.60	13.5	4.42	15.7	5.31	16.8	5.80	17.9	6.31	20.1	7.38	22.3	8.55	
41	11.3	3.72	13.5	4.61	15.7	5.51	16.8	6.03	17.9	6.54	20.1	7.73	22.3	8.93	
43	11.3	3.84	13.5	4.80	15.7	5.70	16.8	6.21	17.9	6.77	20.1	8.05	22.3	9.32	
45	11.3	4.02	13.5	5.04	15.7	5.93	16.8	6.44	17.9	7.11	20.1	8.41	22.3	9.84	
48	11.3	4.17	13.5	5.26	15.7	6.14	16.8	6.60	17.9	7.37	20.1	8.71	22.3	10.31	

Abbreviations:

CR: Combination ratio

TC: Total capacity (kW)

PI: Power input (compressor + outdoor fan motor) (kW)

Notes:

Shaded cells indicate rating condition.

Table 2-8.2: 10HP cooling capacity (continued)

Combination (%) (Capacity index)	Outdoor temperature (°C DB)	Indoor temperature(°C DB/WB)													
		DB:20.8,WB:14		DB:23.3,WB:16		DB:25.8,WB:18		DB:27,WB:19		DB:28.2,WB:20		DB:30.7,WB:22		DB:32,WB:24	
		TC	PI	TC	PI	TC	PI	TC	PI	TC	PI	TC	PI	TC	PI
		kW	kW	kW	kW	kW	kW	kW	kW	kW	kW	kW	kW	kW	kW
50%	-5	9.5	1.71	11.3	1.98	13.1	2.27	14.0	2.38	14.9	2.51	16.7	2.86	18.6	3.08
	-2	9.5	1.72	11.3	2.02	13.1	2.30	14.0	2.41	14.9	2.56	16.7	2.89	18.6	3.12
	0	9.5	1.75	11.3	2.05	13.1	2.34	14.0	2.44	14.9	2.58	16.7	2.94	18.6	3.17
	2	9.5	1.78	11.3	2.08	13.1	2.38	14.0	2.48	14.9	2.63	16.7	2.95	18.6	3.23
	4	9.5	1.79	11.3	2.11	13.1	2.40	14.0	2.51	14.9	2.68	16.7	3.03	18.6	3.32
	6	9.5	1.83	11.3	2.15	13.1	2.44	14.0	2.57	14.9	2.73	16.7	3.07	18.6	3.41
	8	9.5	1.87	11.3	2.18	13.1	2.48	14.0	2.63	14.9	2.77	16.7	3.12	18.6	3.52
	10	9.5	1.91	11.3	2.21	13.1	2.52	14.0	2.67	14.9	2.85	16.7	3.21	18.6	3.58
	12	9.5	1.92	11.3	2.24	13.1	2.56	14.0	2.72	14.9	2.91	16.7	3.26	18.6	3.63
	14	9.5	1.95	11.3	2.26	13.1	2.59	14.0	2.78	14.9	2.95	16.7	3.32	18.6	3.70
	16	9.5	1.98	11.3	2.29	13.1	2.64	14.0	2.82	14.9	2.99	16.7	3.38	18.6	3.76
	18	9.5	2.01	11.3	2.34	13.1	2.68	14.0	2.86	14.9	3.05	16.7	3.43	18.6	3.83
	20	9.5	2.04	11.3	2.36	13.1	2.72	14.0	2.91	14.9	3.11	16.7	3.49	18.6	3.90
	21	9.5	2.05	11.3	2.39	13.1	2.75	14.0	2.93	14.9	3.13	16.7	3.53	18.6	3.95
	23	9.5	2.08	11.3	2.42	13.1	2.79	14.0	2.99	14.9	3.19	16.7	3.59	18.6	4.03
	25	9.5	2.11	11.3	2.46	13.1	2.85	14.0	3.05	14.9	3.29	16.7	3.77	18.6	4.30
	27	9.5	2.15	11.3	2.56	13.1	3.01	14.0	3.25	14.9	3.49	16.7	4.02	18.6	4.59
	29	9.5	2.26	11.3	2.71	13.1	3.19	14.0	3.45	14.9	3.72	16.7	4.27	18.6	4.89
	31	9.5	2.39	11.3	2.86	13.1	3.38	14.0	3.66	14.9	3.95	16.7	4.54	18.6	5.20
	33	9.5	2.54	11.3	3.03	13.1	3.59	14.0	3.87	14.9	4.19	16.7	4.83	18.6	5.53
35	9.5	2.68	11.3	3.21	13.1	3.79	14.0	4.10	14.9	4.43	16.7	5.13	18.6	5.87	
37	9.5	2.82	11.3	3.39	13.1	4.02	14.0	4.34	14.9	4.70	16.7	5.44	18.6	6.24	
39	9.5	2.98	11.3	3.58	13.1	4.24	14.0	4.60	14.9	4.99	16.7	5.77	18.6	6.62	
41	9.5	3.10	11.3	3.73	13.1	4.40	14.0	4.82	14.9	5.20	16.7	6.08	18.6	6.93	
43	9.5	3.31	11.3	3.99	13.1	4.55	14.0	5.03	14.9	5.33	16.7	6.38	18.6	7.24	
45	9.5	3.38	11.3	4.09	13.1	4.86	14.0	5.42	14.9	5.56	16.7	7.00	18.6	7.85	
48	9.5	3.45	11.3	4.18	13.1	5.13	14.0	5.78	14.9	5.83	16.7	7.55	18.6	8.45	

Abbreviations:

CR: Combination ratio

TC: Total capacity (kW)

PI: Power input (compressor + outdoor fan motor) (kW)

Notes:

Shaded cells indicate rating condition.

Table 2-8.3: 12HP cooling capacity

Combination (%) (Capacity index)	Outdoor temperature (°C DB)	Indoor temperature(°C DB/WB)													
		DB:20.8,WB:14		DB:23.3,WB:16		DB:25.8,WB:18		DB:27,WB:19		DB:28.2,WB:20		DB:30.7,WB:22		DB:32,WB:24	
		TC kW	PI kW	TC kW	PI kW	TC kW	PI kW	TC kW	PI kW	TC kW	PI kW	TC kW	PI kW	TC kW	PI kW
130%	-5	29.4	5.54	35.1	6.76	40.7	7.25	42.2	7.54	44.3	7.76	45.3	8.44	46.5	8.49
	-2	29.4	5.54	35.1	6.89	40.7	7.25	42.2	7.59	44.3	7.76	45.3	8.54	46.5	8.57
	0	29.4	5.64	35.1	7.01	40.7	7.51	42.2	8.00	44.3	8.21	45.3	8.65	46.5	8.69
	2	29.4	5.74	35.1	7.03	40.7	7.77	42.2	8.45	44.3	8.30	45.3	8.71	46.5	8.82
	4	29.4	5.86	35.1	7.16	40.7	8.04	42.2	8.49	44.3	8.41	45.3	8.84	46.5	8.99
	6	29.4	5.98	35.1	7.31	40.7	8.34	42.2	8.56	43.8	8.67	44.8	8.98	46.0	9.05
	8	29.4	6.12	35.1	7.47	40.7	8.75	42.2	8.98	43.2	8.96	44.3	9.01	45.4	9.14
	10	29.4	6.25	35.1	7.64	40.7	9.08	42.2	9.28	42.7	9.12	43.8	9.15	44.9	9.40
	12	29.4	6.36	35.1	7.78	40.7	9.26	41.6	9.42	42.2	9.26	43.2	9.28	44.3	9.46
	14	29.4	6.49	35.1	7.93	40.6	9.40	41.2	9.56	41.6	9.40	42.7	9.42	43.8	9.68
	16	29.4	6.59	35.1	8.09	40.1	9.54	40.6	9.68	41.0	9.67	42.1	9.56	43.2	9.83
	18	29.4	6.72	35.1	8.26	39.5	9.68	40.0	9.74	40.6	9.79	41.6	9.88	42.7	9.97
	20	29.4	6.87	35.1	8.79	38.9	10.16	39.5	10.21	40.0	10.27	41.0	10.36	42.1	10.47
	21	29.4	7.05	35.1	9.10	38.6	10.40	39.2	10.45	39.7	10.50	40.8	10.61	41.9	10.70
	23	29.4	7.56	35.1	9.75	38.2	10.87	38.6	10.92	39.1	10.98	40.2	11.09	41.3	11.20
	25	29.4	8.07	35.1	10.45	37.6	11.34	38.0	11.40	38.6	11.47	39.7	11.58	40.8	11.69
	27	29.4	8.62	35.1	11.18	37.1	11.82	37.6	11.89	38.0	11.95	39.1	12.08	40.2	12.20
	29	29.4	9.21	35.1	11.95	36.5	12.29	37.0	12.37	37.6	12.44	38.6	12.57	39.7	12.70
	31	29.4	9.83	34.9	12.64	35.9	12.79	36.5	12.86	37.0	12.91	38.0	13.06	39.1	13.21
	33	29.4	10.47	34.3	13.12	35.4	13.26	35.9	13.34	36.5	13.41	37.6	13.55	38.5	13.70
35	29.4	11.16	33.7	13.59	34.8	13.76	35.4	13.83	35.9	13.90	37.0	14.07	38.0	14.21	
37	29.4	11.87	33.3	14.08	34.3	14.25	34.8	14.32	35.4	14.41	36.4	14.58	37.4	14.74	
39	29.4	12.64	32.7	14.23	33.7	14.72	34.3	14.81	34.8	14.91	35.9	15.07	37.0	15.25	
41	29.4	13.30	32.3	14.37	33.4	14.86	34.0	14.95	34.5	15.04	35.5	15.10	35.6	15.39	
43	29.4	13.64	32.1	14.44	33.2	14.90	33.8	15.02	34.1	15.06	34.9	15.13	35.1	15.43	
45	29.4	14.32	31.9	14.58	32.9	15.04	33.5	15.12	33.6	15.13	33.9	15.18	34.4	15.72	
48	29.4	14.81	31.8	15.04	32.3	15.17	32.9	15.24	33.2	15.29	33.0	15.45	33.6	15.77	
120%	-5	27.2	5.35	32.3	6.48	37.6	7.66	40.2	8.36	42.1	8.71	43.1	8.99	44.0	9.23
	-2	27.2	5.40	32.3	6.55	37.6	7.74	40.2	8.41	42.1	8.82	43.1	9.07	44.0	9.26
	0	27.2	5.45	32.3	6.59	37.6	7.83	40.2	8.43	42.1	8.89	43.1	9.12	44.0	9.28
	2	27.2	5.47	32.3	6.66	37.6	7.88	40.2	8.51	42.1	8.93	43.1	9.19	44.0	9.30
	4	27.2	5.52	32.3	6.75	37.6	7.99	40.2	8.59	42.1	9.05	43.1	9.21	44.0	9.33
	6	27.2	5.58	32.3	6.80	37.6	8.09	40.2	8.68	42.1	9.15	43.1	9.28	44.0	9.35
	8	27.2	5.63	32.3	6.87	37.6	8.20	40.2	8.79	42.1	9.24	43.1	9.31	44.0	9.40
	10	27.2	5.70	32.3	6.96	37.6	8.27	40.2	8.95	42.1	9.24	43.1	9.34	44.0	9.44
	12	27.2	5.81	32.3	7.09	37.6	8.44	40.2	9.12	41.5	9.28	42.5	9.29	43.4	9.50
	14	27.2	5.92	32.3	7.23	37.6	8.60	40.2	9.30	40.9	9.34	42.0	9.43	43.0	9.62
	16	27.2	6.03	32.3	7.38	37.6	8.77	40.0	9.46	40.4	9.48	41.4	9.59	42.4	9.76
	18	27.2	6.14	32.3	7.53	37.6	9.06	39.4	9.68	39.8	9.72	40.8	9.81	41.9	9.90
	20	27.2	6.27	32.3	7.82	37.6	9.75	38.9	10.16	39.4	10.19	40.3	10.28	41.3	10.38
	21	27.2	6.32	32.3	8.09	37.6	10.10	38.5	10.39	39.0	10.43	40.1	10.52	41.0	10.63
	23	27.2	6.76	32.3	8.68	37.6	10.81	38.0	10.85	38.5	10.91	39.5	11.02	40.4	11.11
	25	27.2	7.22	32.3	9.28	37.0	11.29	37.4	11.33	37.9	11.38	39.0	11.49	40.0	11.60
	27	27.2	7.71	32.3	9.92	36.5	11.75	37.0	11.82	37.4	11.87	38.4	11.98	39.4	12.09
	29	27.2	8.22	32.3	10.59	35.9	12.22	36.4	12.29	36.9	12.35	37.8	12.48	38.9	12.59
	31	27.2	8.77	32.3	11.31	35.3	12.71	35.9	12.77	36.4	12.84	37.3	12.97	38.3	13.10
	33	27.2	9.33	32.3	12.06	34.8	13.19	35.3	13.26	35.8	13.32	36.7	13.46	37.7	13.59
35	27.2	9.94	32.3	12.86	34.2	13.66	34.7	13.74	35.3	13.81	36.3	13.96	37.2	14.10	
37	27.2	10.58	32.3	13.70	33.7	14.16	34.2	14.23	34.7	14.30	35.7	14.45	36.6	14.61	
39	27.2	11.25	32.2	14.47	33.1	14.63	33.6	14.72	34.1	14.80	35.2	14.96	36.1	15.11	
41	27.2	11.56	31.9	14.57	32.9	14.74	33.4	14.83	33.8	14.90	34.9	15.00	35.1	15.22	
43	27.2	11.73	31.8	14.67	32.6	14.82	33.1	14.88	33.6	14.95	34.3	15.04	34.5	15.53	
45	27.2	11.87	31.6	14.81	32.3	14.96	32.8	15.02	33.3	15.07	33.6	15.09	34.2	15.86	
48	27.2	11.95	31.3	14.97	31.9	15.09	32.2	15.11	32.9	15.21	33.1	15.25	33.8	16.06	

Abbreviations:
 CR: Combination ratio
 TC: Total capacity (kW)
 PI: Power input (compressor + outdoor fan motor) (kW)

Notes:
 Shaded cells indicate rating condition.

Table continued on next page ...

Table 2-8.3: 12HP cooling capacity (continued)

Combination (%) (Capacity index)	Outdoor temperature (°C DB)	Indoor temperature(°C DB/WB)													
		DB:20.8,WB:14		DB:23.3,WB:16		DB:25.8,WB:18		DB:27,WB:19		DB:28.2,WB:20		DB:30.7,WB:22		DB:32,WB:24	
		TC	PI	TC	PI	TC	PI	TC	PI	TC	PI	TC	PI	TC	PI
110%	-5	24.9	4.67	29.7	5.82	34.5	6.94	36.9	7.45	39.2	8.02	42.2	8.33	43.2	8.58
	-2	24.9	4.76	29.7	5.89	34.5	7.00	36.9	7.53	39.2	8.08	42.2	8.41	43.2	8.63
	0	24.9	4.81	29.7	5.93	34.5	7.05	36.9	7.57	39.2	8.17	42.2	8.49	43.2	8.73
	2	24.9	4.92	29.7	5.98	34.5	7.16	36.9	7.66	39.2	8.26	42.2	8.61	43.2	8.84
	4	24.9	5.01	29.7	6.05	34.5	7.23	36.9	7.75	39.2	8.38	42.2	8.73	43.2	8.92
	6	24.9	5.06	29.7	6.12	34.5	7.30	36.9	7.87	39.2	8.48	42.2	8.82	43.2	9.06
	8	24.9	5.11	29.7	6.22	34.5	7.39	36.9	7.96	39.2	8.57	42.2	8.88	43.2	9.16
	10	24.9	5.17	29.7	6.30	34.5	7.49	36.9	8.09	39.2	8.71	42.2	8.95	43.2	9.24
	12	24.9	5.28	29.7	6.43	34.5	7.64	36.9	8.26	39.2	8.88	41.8	9.08	42.6	9.36
	14	24.9	5.37	29.7	6.54	34.5	7.78	36.9	8.40	39.2	9.04	41.2	9.15	42.1	9.42
	16	24.9	5.46	29.7	6.67	34.5	7.93	36.9	8.57	39.2	9.22	40.7	9.26	41.5	9.52
	18	24.9	5.57	29.7	6.80	34.5	8.09	36.9	8.80	39.2	9.66	40.1	9.74	41.0	9.83
	20	24.9	5.68	29.7	6.94	34.5	8.57	36.9	9.46	38.6	10.14	39.6	10.21	40.4	10.30
	21	24.9	5.74	29.7	7.14	34.5	8.88	36.9	9.81	38.4	10.38	39.2	10.45	40.2	10.54
	23	24.9	6.01	29.7	7.65	34.5	9.52	36.9	10.52	37.8	10.83	38.8	10.94	39.6	11.03
	25	24.9	6.41	29.7	8.18	34.5	10.17	36.9	11.27	37.3	11.31	38.2	11.42	39.1	11.51
	27	24.9	6.83	29.7	8.75	34.5	10.89	36.3	11.75	36.7	11.78	37.7	11.89	38.5	12.00
	29	24.9	7.29	29.7	9.34	34.5	11.64	35.8	12.22	36.3	12.28	37.1	12.38	38.0	12.50
	31	24.9	7.76	29.7	9.96	34.5	12.42	35.2	12.70	35.7	12.75	36.6	12.86	37.4	12.99
	33	24.9	8.26	29.7	10.61	34.2	13.10	34.7	13.17	35.2	13.23	36.0	13.35	37.0	13.48
35	24.9	8.79	29.7	11.31	33.6	13.57	34.1	13.65	34.6	13.72	35.4	13.85	36.4	13.97	
37	24.9	9.35	29.7	12.04	33.1	14.07	33.6	14.12	34.0	14.19	34.9	14.34	35.8	14.47	
39	24.9	9.94	29.7	12.82	32.5	14.54	33.0	14.61	33.5	14.69	34.3	14.83	35.3	14.98	
41	24.9	10.04	29.7	12.93	32.3	14.64	32.8	14.72	33.2	14.79	33.9	14.94	34.2	15.08	
43	24.9	10.14	29.7	13.09	32.0	14.75	32.5	14.82	33.0	14.89	33.6	14.99	33.7	15.39	
45	24.9	10.47	29.7	13.17	31.7	14.88	32.2	15.00	32.7	15.03	33.3	15.40	33.4	15.75	
48	24.9	10.81	29.7	14.25	31.2	14.95	31.7	15.07	32.3	15.16	32.7	15.42	33.0	15.88	
100%	-5	22.6	4.26	26.9	5.12	31.3	6.10	33.5	6.53	35.7	7.09	40.1	8.08	42.4	8.43
	-2	22.6	4.31	26.9	5.19	31.3	6.17	33.5	6.65	35.7	7.18	40.1	8.17	42.4	8.48
	0	22.6	4.35	26.9	5.25	31.3	6.23	33.5	6.74	35.7	7.25	40.1	8.31	42.4	8.58
	2	22.6	4.44	26.9	5.32	31.3	6.30	33.5	6.82	35.7	7.33	40.1	8.43	42.4	8.71
	4	22.6	4.47	26.9	5.37	31.3	6.40	33.5	6.93	35.7	7.43	40.1	8.51	42.4	8.81
	6	22.6	4.53	26.9	5.48	31.3	6.48	33.5	7.05	35.7	7.54	40.1	8.63	42.4	8.95
	8	22.6	4.62	26.9	5.56	31.3	6.60	33.5	7.13	35.7	7.66	40.1	8.77	42.4	9.09
	10	22.6	4.68	26.9	5.66	31.3	6.70	33.5	7.25	35.7	7.80	40.1	8.91	42.4	9.22
	12	22.6	4.75	26.9	5.77	31.3	6.83	33.5	7.38	35.7	7.95	40.1	9.08	41.8	9.30
	14	22.6	4.84	26.9	5.88	31.3	6.96	33.5	7.53	35.7	8.09	40.1	9.26	41.3	9.41
	16	22.6	4.93	26.9	5.99	31.3	7.11	33.5	7.67	35.7	8.26	39.8	9.37	40.7	9.52
	18	22.6	5.02	26.9	6.10	31.3	7.23	33.5	7.82	35.7	8.42	39.4	9.68	40.2	9.75
	20	22.6	5.12	26.9	6.23	31.3	7.45	33.5	8.22	35.7	9.02	38.8	10.14	39.6	10.23
	21	22.6	5.17	26.9	6.28	31.3	7.73	33.5	8.51	35.7	9.33	38.5	10.38	39.4	10.47
	23	22.6	5.30	26.9	6.70	31.3	8.27	33.5	9.11	35.7	10.01	38.0	10.85	38.8	10.94
	25	22.6	5.64	26.9	7.16	31.3	8.86	33.5	9.77	35.7	10.72	37.4	11.33	38.3	11.42
	27	22.6	6.03	26.9	7.63	31.3	9.46	33.5	10.45	35.7	11.47	36.9	11.80	37.7	11.91
	29	22.6	6.41	26.9	8.15	31.3	10.10	33.5	11.16	35.5	12.18	36.4	12.29	37.2	12.38
	31	22.6	6.83	26.9	8.69	31.3	10.78	33.5	11.91	35.1	12.66	35.8	12.77	36.6	12.88
	33	22.6	7.25	26.9	9.26	31.3	11.49	33.5	12.71	34.5	13.13	35.3	13.24	36.1	13.37
35	22.6	7.71	26.9	9.85	31.3	12.26	33.5	13.55	33.9	13.61	34.7	13.74	35.5	13.85	
37	22.6	8.20	26.9	10.49	31.3	13.06	32.9	14.03	33.4	14.10	34.2	14.23	34.9	14.34	
39	22.6	8.71	26.9	11.14	31.3	13.90	32.4	14.50	32.8	14.58	33.6	14.70	34.5	14.85	
41	22.6	9.12	26.9	11.55	31.3	14.41	31.9	14.61	32.5	14.80	33.0	15.05	34.0	15.16	
43	22.6	9.53	26.9	11.96	31.3	14.68	31.4	14.77	32.3	14.94	33.2	15.15	33.4	15.33	
45	22.6	10.07	26.9	12.50	31.3	14.93	30.7	14.98	32.1	15.21	33.0	15.38	32.7	15.53	
48	22.6	10.51	26.9	12.94	31.3	14.95	29.5	15.15	32.1	15.48	30.9	15.54	32.0	15.67	

Abbreviations:

CR: Combination ratio

TC: Total capacity (kW)

PI: Power input (compressor + outdoor fan motor) (kW)

Notes:

Shaded cells indicate rating condition.

Table continued on next page ...

Table 2-8.3: 12HP cooling capacity (continued)

Combination (%) (Capacity index)	Outdoor temperature (°C DB)	Indoor temperature(°C DB/WB)													
		DB:20.8,WB:14		DB:23.3,WB:16		DB:25.8,WB:18		DB:27,WB:19		DB:28.2,WB:20		DB:30.7,WB:22		DB:32,WB:24	
		TC kW	PI kW	TC kW	PI kW	TC kW	PI kW	TC kW	PI kW	TC kW	PI kW	TC kW	PI kW	TC kW	PI kW
90%	-5	20.3	3.76	24.3	4.52	28.2	5.33	30.2	5.81	32.1	6.18	36.0	7.11	40.0	8.14
	-2	20.3	3.80	24.3	4.56	28.2	5.40	30.2	5.89	32.1	6.26	36.0	7.18	40.0	8.22
	0	20.3	3.86	24.3	4.62	28.2	5.48	30.2	5.96	32.1	6.34	36.0	7.26	40.0	8.29
	2	20.3	3.91	24.3	4.68	28.2	5.54	30.2	6.06	32.1	6.44	36.0	7.41	40.0	8.41
	4	20.3	3.97	24.3	4.75	28.2	5.63	30.2	6.14	32.1	6.52	36.0	7.53	40.0	8.53
	6	20.3	4.03	24.3	4.84	28.2	5.73	30.2	6.25	32.1	6.63	36.0	7.64	40.0	8.67
	8	20.3	4.11	24.3	4.93	28.2	5.85	30.2	6.33	32.1	6.75	36.0	7.79	40.0	8.75
	10	20.3	4.18	24.3	5.04	28.2	5.95	30.2	6.43	32.1	6.90	36.0	7.89	40.0	8.89
	12	20.3	4.26	24.3	5.13	28.2	6.06	30.2	6.54	32.1	7.03	36.0	8.04	40.0	9.06
	14	20.3	4.33	24.3	5.22	28.2	6.17	30.2	6.67	32.1	7.16	36.0	8.18	40.0	9.22
	16	20.3	4.40	24.3	5.32	28.2	6.30	30.2	6.80	32.1	7.31	36.0	8.35	39.8	9.39
	18	20.3	4.47	24.3	5.43	28.2	6.41	30.2	6.92	32.1	7.45	36.0	8.51	39.4	9.68
	20	20.3	4.57	24.3	5.55	28.2	6.54	30.2	7.07	32.1	7.73	36.0	9.15	38.8	10.14
	21	20.3	4.60	24.3	5.59	28.2	6.65	30.2	7.31	32.1	8.00	36.0	9.48	38.5	10.37
	23	20.3	4.69	24.3	5.81	28.2	7.12	30.2	7.84	32.1	8.58	36.0	10.17	37.9	10.85
	25	20.3	4.95	24.3	6.21	28.2	7.62	30.2	8.38	32.1	9.17	36.0	10.89	37.4	11.32
	27	20.3	5.26	24.3	6.61	28.2	8.13	30.2	8.95	32.1	9.81	36.0	11.65	36.8	11.80
	29	20.3	5.61	24.3	7.05	28.2	8.68	30.2	9.55	32.1	10.48	35.7	12.18	36.4	12.27
	31	20.3	5.95	24.3	7.51	28.2	9.24	30.2	10.19	32.1	11.18	35.1	12.66	35.8	12.77
	33	20.3	6.32	24.3	7.98	28.2	9.86	30.2	10.87	32.1	11.93	34.6	13.15	35.3	13.24
35	20.3	6.72	24.3	8.49	28.2	10.50	30.2	11.58	32.1	12.71	34.0	13.63	34.7	13.74	
37	20.3	7.12	24.3	9.02	28.2	11.18	30.2	12.33	32.1	13.55	33.4	14.10	34.2	14.21	
39	20.3	7.56	24.3	9.61	28.2	11.89	30.2	13.13	32.1	14.43	32.9	14.59	33.6	14.70	
41	20.3	7.82	24.3	10.04	28.2	12.32	30.2	13.48	32.1	14.52	32.7	14.97	33.4	15.05	
43	20.3	8.20	24.3	10.48	28.2	12.76	30.2	13.83	32.1	14.83	32.5	15.16	33.1	15.28	
45	20.3	8.72	24.3	11.00	28.2	13.28	30.2	14.29	32.1	15.24	32.3	15.32	32.6	15.49	
48	20.3	9.20	24.3	11.50	28.2	13.78	30.2	14.47	32.1	15.37	32.1	15.53	31.7	15.70	
80%	-5	18.1	3.32	21.5	3.92	25.0	4.64	26.8	4.94	28.6	5.32	32.1	6.15	35.5	7.01
	-2	18.1	3.37	21.5	3.97	25.0	4.68	26.8	5.01	28.6	5.36	32.1	6.20	35.5	7.08
	0	18.1	3.42	21.5	4.02	25.0	4.74	26.8	5.07	28.6	5.46	32.1	6.29	35.5	7.18
	2	18.1	3.49	21.5	4.08	25.0	4.81	26.8	5.17	28.6	5.56	32.1	6.42	35.5	7.32
	4	18.1	3.55	21.5	4.15	25.0	4.90	26.8	5.29	28.6	5.66	32.1	6.54	35.5	7.41
	6	18.1	3.61	21.5	4.24	25.0	4.97	26.8	5.40	28.6	5.76	32.1	6.63	35.5	7.54
	8	18.1	3.68	21.5	4.34	25.0	5.09	26.8	5.49	28.6	5.89	32.1	6.73	35.5	7.69
	10	18.1	3.71	21.5	4.44	25.0	5.22	26.8	5.63	28.6	6.03	32.1	6.89	35.5	7.76
	12	18.1	3.76	21.5	4.51	25.0	5.32	26.8	5.74	28.6	6.16	32.1	7.01	35.5	7.91
	14	18.1	3.84	21.5	4.60	25.0	5.41	26.8	5.83	28.6	6.27	32.1	7.14	35.5	8.06
	16	18.1	3.89	21.5	4.68	25.0	5.52	26.8	5.94	28.6	6.38	32.1	7.29	35.5	8.20
	18	18.1	3.96	21.5	4.77	25.0	5.63	26.8	6.06	28.6	6.50	32.1	7.43	35.5	8.37
	20	18.1	4.04	21.5	4.86	25.0	5.74	26.8	6.17	28.6	6.63	32.1	7.71	35.5	8.95
	21	18.1	4.07	21.5	4.90	25.0	5.79	26.8	6.25	28.6	6.78	32.1	7.98	35.5	9.28
	23	18.1	4.15	21.5	5.01	25.0	6.06	26.8	6.65	28.6	7.25	32.1	8.55	35.5	9.96
	25	18.1	4.27	21.5	5.32	25.0	6.48	26.8	7.11	28.6	7.75	32.1	9.15	35.5	10.65
	27	18.1	4.55	21.5	5.66	25.0	6.91	26.8	7.58	28.6	8.27	32.1	9.77	35.5	11.40
	29	18.1	4.84	21.5	6.03	25.0	7.36	26.8	8.07	28.6	8.84	32.1	10.43	35.5	12.18
	31	18.1	5.13	21.5	6.41	25.0	7.84	26.8	8.60	28.6	9.43	32.1	11.14	34.9	12.66
	33	18.1	5.46	21.5	6.81	25.0	8.35	26.8	9.17	28.6	10.03	32.1	11.87	34.5	13.13
35	18.1	5.79	21.5	7.25	25.0	8.88	26.8	9.75	28.6	10.69	32.1	12.66	33.9	13.61	
37	18.1	6.14	21.5	7.69	25.0	9.44	26.8	10.39	28.6	11.38	32.1	13.50	33.4	14.08	
39	18.1	6.50	21.5	8.20	25.0	10.05	26.8	11.05	28.6	12.11	32.1	14.38	32.8	14.58	
41	18.1	6.65	21.5	8.27	25.0	10.19	26.8	11.34	28.6	12.33	32.1	14.74	32.6	14.83	
43	18.1	6.84	21.5	8.35	25.0	10.34	26.8	11.54	28.6	12.50	32.1	14.91	32.4	14.99	
45	18.1	7.04	21.5	8.45	25.0	10.54	26.8	11.78	28.6	12.72	32.1	15.08	32.0	15.24	
48	18.1	7.27	21.5	8.50	25.0	10.70	26.8	11.94	28.6	12.82	32.1	15.22	31.7	15.43	

Abbreviations:
 CR: Combination ratio
 TC: Total capacity (kW)
 PI: Power input (compressor + outdoor fan motor) (kW)

Notes:
 Shaded cells indicate rating condition.

Table continued on next page ...

Table 2-8.3: 12HP cooling capacity (continued)

Combination (%) (Capacity index)	Outdoor temperature (°C DB)	Indoor temperature(°C DB/WB)													
		DB:20.8,WB:14		DB:23.3,WB:16		DB:25.8,WB:18		DB:27,WB:19		DB:28.2,WB:20		DB:30.7,WB:22		DB:32,WB:24	
		TC kW	PI kW	TC kW	PI kW	TC kW	PI kW	TC kW	PI kW	TC kW	PI kW	TC kW	PI kW	TC kW	PI kW
70%	-5	15.8	2.96	18.9	3.47	21.9	3.93	23.5	4.22	25.0	4.50	28.0	5.15	31.1	5.92
	-2	15.8	2.98	18.9	3.49	21.9	3.96	23.5	4.30	25.0	4.58	28.0	5.23	31.1	6.00
	0	15.8	3.00	18.9	3.54	21.9	4.04	23.5	4.38	25.0	4.66	28.0	5.34	31.1	6.08
	2	15.8	3.02	18.9	3.55	21.9	4.10	23.5	4.46	25.0	4.74	28.0	5.45	31.1	6.18
	4	15.8	3.06	18.9	3.64	21.9	4.19	23.5	4.54	25.0	4.85	28.0	5.54	31.1	6.33
	6	15.8	3.11	18.9	3.70	21.9	4.30	23.5	4.69	25.0	4.96	28.0	5.64	31.1	6.45
	8	15.8	3.16	18.9	3.81	21.9	4.40	23.5	4.76	25.0	5.07	28.0	5.80	31.1	6.57
	10	15.8	3.23	18.9	3.87	21.9	4.51	23.5	4.86	25.0	5.21	28.0	5.92	31.1	6.65
	12	15.8	3.31	18.9	3.93	21.9	4.60	23.5	4.95	25.0	5.30	28.0	6.03	31.1	6.78
	14	15.8	3.36	18.9	4.00	21.9	4.68	23.5	5.02	25.0	5.39	28.0	6.14	31.1	6.91
	16	15.8	3.42	18.9	4.07	21.9	4.77	23.5	5.13	25.0	5.50	28.0	6.25	31.1	7.03
	18	15.8	3.47	18.9	4.15	21.9	4.86	23.5	5.22	25.0	5.59	28.0	6.37	31.1	7.18
	20	15.8	3.53	18.9	4.22	21.9	4.95	23.5	5.32	25.0	5.70	28.0	6.50	31.1	7.38
	21	15.8	3.56	18.9	4.26	21.9	4.99	23.5	5.37	25.0	5.75	28.0	6.59	31.1	7.64
	23	15.8	3.62	18.9	4.33	21.9	5.10	23.5	5.55	25.0	6.05	28.0	7.07	31.1	8.18
	25	15.8	3.69	18.9	4.51	21.9	5.43	23.5	5.94	25.0	6.45	28.0	7.56	31.1	8.75
	27	15.8	3.91	18.9	4.80	21.9	5.79	23.5	6.32	25.0	6.89	28.0	8.07	31.1	9.35
	29	15.8	4.15	18.9	5.10	21.9	6.16	23.5	6.74	25.0	7.33	28.0	8.60	31.1	9.99
	31	15.8	4.38	18.9	5.41	21.9	6.56	23.5	7.16	25.0	7.80	28.0	9.17	31.1	10.65
	33	15.8	4.66	18.9	5.75	21.9	6.98	23.5	7.62	25.0	8.31	28.0	9.77	31.1	11.36
35	15.8	4.93	18.9	6.10	21.9	7.40	23.5	8.11	25.0	8.84	28.0	10.41	31.1	12.11	
37	15.8	5.21	18.9	6.47	21.9	7.87	23.5	8.60	25.0	9.41	28.0	11.09	31.1	12.90	
39	15.8	5.52	18.9	6.85	21.9	8.35	23.5	9.15	25.0	9.99	28.0	11.78	31.1	13.74	
41	15.8	5.76	18.9	7.09	21.9	8.59	23.5	9.46	25.0	10.30	28.0	12.27	31.1	14.34	
43	15.8	6.23	18.9	7.58	21.9	8.95	23.5	9.96	25.0	10.60	28.0	12.71	31.1	14.79	
45	15.8	6.37	18.9	7.74	21.9	9.13	23.5	10.13	25.0	11.13	28.0	13.40	31.1	15.36	
48	15.8	6.49	18.9	7.79	21.9	9.25	23.5	10.30	25.0	11.44	28.0	14.03	31.1	15.73	
60%	-5	13.5	2.53	16.2	2.93	18.8	3.41	20.1	3.64	21.4	3.93	24.0	4.41	26.7	5.06
	-2	13.5	2.54	16.2	2.98	18.8	3.48	20.1	3.69	21.4	3.97	24.0	4.48	26.7	5.09
	0	13.5	2.58	16.2	3.01	18.8	3.52	20.1	3.74	21.4	4.03	24.0	4.54	26.7	5.16
	2	13.5	2.62	16.2	3.08	18.8	3.59	20.1	3.81	21.4	4.09	24.0	4.63	26.7	5.22
	4	13.5	2.70	16.2	3.14	18.8	3.66	20.1	3.85	21.4	4.15	24.0	4.71	26.7	5.30
	6	13.5	2.72	16.2	3.20	18.8	3.73	20.1	3.94	21.4	4.23	24.0	4.80	26.7	5.42
	8	13.5	2.78	16.2	3.25	18.8	3.80	20.1	4.01	21.4	4.32	24.0	4.89	26.7	5.51
	10	13.5	2.83	16.2	3.32	18.8	3.85	20.1	4.13	21.4	4.40	24.0	4.99	26.7	5.59
	12	13.5	2.89	16.2	3.38	18.8	3.93	20.1	4.20	21.4	4.47	24.0	5.08	26.7	5.68
	14	13.5	2.92	16.2	3.43	18.8	3.98	20.1	4.27	21.4	4.57	24.0	5.17	26.7	5.79
	16	13.5	2.96	16.2	3.49	18.8	4.05	20.1	4.35	21.4	4.64	24.0	5.26	26.7	5.90
	18	13.5	3.01	16.2	3.54	18.8	4.13	20.1	4.42	21.4	4.73	24.0	5.35	26.7	6.01
	20	13.5	3.05	16.2	3.62	18.8	4.20	20.1	4.51	21.4	4.82	24.0	5.46	26.7	6.14
	21	13.5	3.09	16.2	3.63	18.8	4.24	20.1	4.55	21.4	4.86	24.0	5.52	26.7	6.19
	23	13.5	3.12	16.2	3.71	18.8	4.31	20.1	4.64	21.4	4.95	24.0	5.73	26.7	6.59
	25	13.5	3.18	16.2	3.76	18.8	4.47	20.1	4.86	21.4	5.26	24.0	6.12	26.7	7.03
	27	13.5	3.31	16.2	4.00	18.8	4.77	20.1	5.19	21.4	5.61	24.0	6.52	26.7	7.51
	29	13.5	3.49	16.2	4.24	18.8	5.08	20.1	5.52	21.4	5.97	24.0	6.96	26.7	8.02
	31	13.5	3.71	16.2	4.49	18.8	5.39	20.1	5.86	21.4	6.36	24.0	7.40	26.7	8.53
	33	13.5	3.91	16.2	4.77	18.8	5.72	20.1	6.23	21.4	6.76	24.0	7.87	26.7	9.10
35	13.5	4.15	16.2	5.06	18.8	6.06	20.1	6.61	21.4	7.18	24.0	8.38	26.7	9.68	
37	13.5	4.38	16.2	5.35	18.8	6.43	20.1	7.01	21.4	7.62	24.0	8.91	26.7	10.30	
39	13.5	4.62	16.2	5.66	18.8	6.81	20.1	7.43	21.4	8.09	24.0	9.46	26.7	10.96	
41	13.5	4.77	16.2	5.91	18.8	7.06	20.1	7.73	21.4	8.39	24.0	9.91	26.7	11.45	
43	13.5	4.92	16.2	6.16	18.8	7.31	20.1	7.96	21.4	8.68	24.0	10.33	26.7	11.95	
45	13.5	5.15	16.2	6.47	18.8	7.61	20.1	8.26	21.4	9.11	24.0	10.79	26.7	12.61	
48	13.5	5.34	16.2	6.74	18.8	7.87	20.1	8.46	21.4	9.45	24.0	11.17	26.7	13.22	

Abbreviations:

CR: Combination ratio

TC: Total capacity (kW)

PI: Power input (compressor + outdoor fan motor) (kW)

Notes:

Shaded cells indicate rating condition.

Table continued on next page ...

Table 2-8.3: 12HP cooling capacity (continued)

Combination (%) (Capacity index)	Outdoor temperature (°C DB)	Indoor temperature(°C DB/WB)													
		DB:20.8,WB:14		DB:23.3,WB:16		DB:25.8,WB:18		DB:27,WB:19		DB:28.2,WB:20		DB:30.7,WB:22		DB:32,WB:24	
		TC	PI	TC	PI	TC	PI	TC	PI	TC	PI	TC	PI	TC	PI
50%	-5	11.3	2.19	13.5	2.54	15.7	2.91	16.8	3.05	17.8	3.22	20.0	3.66	22.3	3.95
	-2	11.3	2.21	13.5	2.59	15.7	2.95	16.8	3.09	17.8	3.28	20.0	3.71	22.3	4.00
	0	11.3	2.25	13.5	2.63	15.7	3.00	16.8	3.14	17.8	3.31	20.0	3.77	22.3	4.07
	2	11.3	2.28	13.5	2.66	15.7	3.05	16.8	3.18	17.8	3.37	20.0	3.79	22.3	4.14
	4	11.3	2.30	13.5	2.71	15.7	3.08	16.8	3.22	17.8	3.44	20.0	3.88	22.3	4.25
	6	11.3	2.34	13.5	2.75	15.7	3.13	16.8	3.29	17.8	3.50	20.0	3.94	22.3	4.38
	8	11.3	2.40	13.5	2.80	15.7	3.18	16.8	3.37	17.8	3.55	20.0	4.00	22.3	4.52
	10	11.3	2.45	13.5	2.83	15.7	3.23	16.8	3.42	17.8	3.65	20.0	4.11	22.3	4.58
	12	11.3	2.47	13.5	2.87	15.7	3.29	16.8	3.49	17.8	3.73	20.0	4.18	22.3	4.66
	14	11.3	2.50	13.5	2.90	15.7	3.32	16.8	3.56	17.8	3.78	20.0	4.26	22.3	4.75
	16	11.3	2.54	13.5	2.94	15.7	3.38	16.8	3.62	17.8	3.84	20.0	4.33	22.3	4.82
	18	11.3	2.58	13.5	3.00	15.7	3.43	16.8	3.67	17.8	3.91	20.0	4.40	22.3	4.91
	20	11.3	2.61	13.5	3.03	15.7	3.49	16.8	3.73	17.8	3.98	20.0	4.47	22.3	5.00
	21	11.3	2.63	13.5	3.07	15.7	3.52	16.8	3.76	17.8	4.02	20.0	4.53	22.3	5.06
	23	11.3	2.67	13.5	3.11	15.7	3.58	16.8	3.84	17.8	4.09	20.0	4.60	22.3	5.17
	25	11.3	2.70	13.5	3.16	15.7	3.65	16.8	3.91	17.8	4.22	20.0	4.84	22.3	5.52
	27	11.3	2.76	13.5	3.29	15.7	3.85	16.8	4.16	17.8	4.47	20.0	5.15	22.3	5.88
	29	11.3	2.90	13.5	3.47	15.7	4.09	16.8	4.42	17.8	4.77	20.0	5.48	22.3	6.26
	31	11.3	3.07	13.5	3.67	15.7	4.33	16.8	4.69	17.8	5.06	20.0	5.83	22.3	6.67
	33	11.3	3.25	13.5	3.89	15.7	4.60	16.8	4.97	17.8	5.37	20.0	6.19	22.3	7.09
35	11.3	3.43	13.5	4.11	15.7	4.86	16.8	5.26	17.8	5.68	20.0	6.58	22.3	7.53	
37	11.3	3.62	13.5	4.35	15.7	5.15	16.8	5.57	17.8	6.03	20.0	6.98	22.3	8.00	
39	11.3	3.82	13.5	4.58	15.7	5.44	16.8	5.90	17.8	6.39	20.0	7.40	22.3	8.49	
41	11.3	3.98	13.5	4.78	15.7	5.64	16.8	6.18	17.8	6.67	20.0	7.79	22.3	8.89	
43	11.3	4.24	13.5	5.11	15.7	5.84	16.8	6.45	17.8	6.84	20.0	8.19	22.3	9.28	
45	11.3	4.34	13.5	5.24	15.7	6.23	16.8	6.95	17.8	7.13	20.0	8.98	22.3	10.07	
48	11.3	4.42	13.5	5.37	15.7	6.58	16.8	7.42	17.8	7.47	20.0	9.68	22.3	10.84	

Abbreviations:

CR: Combination ratio

TC: Total capacity (kW)

PI: Power input (compressor + outdoor fan motor) (kW)

Notes:

Shaded cells indicate rating condition.

Table 2-8.4: 14HP cooling capacity

Combination (%) (Capacity index)	Outdoor temperature (°C DB)	Indoor temperature(°C DB/WB)													
		DB:20.8,WB:14		DB:23.3,WB:16		DB:25.8,WB:18		DB:27,WB:19		DB:28.2,WB:20		DB:30.7,WB:22		DB:32,WB:24	
		TC	PI	TC	PI	TC	PI	TC	PI	TC	PI	TC	PI	TC	PI
130%	-5	35.1	6.22	41.9	7.59	48.6	8.13	50.4	8.46	52.9	8.71	54.1	9.47	55.5	9.53
	-2	35.1	6.22	41.9	7.74	48.6	8.13	50.4	8.51	52.9	8.71	54.1	9.59	55.5	9.62
	0	35.1	6.32	41.9	7.87	48.6	8.43	50.4	8.98	52.9	9.21	54.1	9.70	55.5	9.75
	2	35.1	6.44	41.9	7.89	48.6	8.72	50.4	9.49	52.9	9.32	54.1	9.77	55.5	9.89
	4	35.1	6.58	41.9	8.04	48.6	9.02	50.4	9.53	52.9	9.44	54.1	9.92	55.5	10.08
	6	35.1	6.71	41.9	8.20	48.6	9.36	50.4	9.61	52.3	9.73	53.5	10.08	54.9	10.16
	8	35.1	6.87	41.9	8.39	48.6	9.82	50.4	10.08	51.6	10.05	52.9	10.11	54.2	10.26
	10	35.1	7.01	41.9	8.57	48.6	10.19	50.4	10.41	51.0	10.24	52.3	10.26	53.6	10.55
	12	35.1	7.13	41.9	8.73	48.6	10.39	49.7	10.57	50.4	10.39	51.6	10.42	52.9	10.62
	14	35.1	7.28	41.9	8.90	48.4	10.55	49.1	10.72	49.7	10.55	51.0	10.57	52.3	10.86
	16	35.1	7.40	41.9	9.08	47.9	10.70	48.4	10.86	49.0	10.86	50.3	10.73	51.6	11.03
	18	35.1	7.54	41.9	9.27	47.1	10.86	47.7	10.93	48.4	10.99	49.7	11.09	51.0	11.19
	20	35.1	7.71	41.9	9.86	46.4	11.40	47.1	11.46	47.7	11.52	49.0	11.62	50.3	11.75
	21	35.1	7.91	41.9	10.21	46.1	11.66	46.9	11.73	47.4	11.79	48.7	11.91	50.0	12.01
	23	35.1	8.49	41.9	10.95	45.6	12.20	46.1	12.26	46.7	12.32	48.0	12.44	49.3	12.57
	25	35.1	9.06	41.9	11.73	44.9	12.73	45.4	12.79	46.1	12.87	47.4	13.00	48.7	13.12
	27	35.1	9.68	41.9	12.55	44.3	13.26	44.9	13.34	45.4	13.41	46.7	13.55	48.0	13.69
	29	35.1	10.33	41.9	13.41	43.6	13.80	44.1	13.88	44.9	13.96	46.1	14.10	47.4	14.25
	31	35.1	11.03	41.7	14.18	42.9	14.35	43.6	14.43	44.1	14.49	45.4	14.66	46.7	14.82
	33	35.1	11.75	41.0	14.72	42.3	14.88	42.9	14.96	43.6	15.05	44.9	15.21	46.0	15.38
35	35.1	12.52	40.3	15.25	41.6	15.44	42.3	15.52	42.9	15.60	44.1	15.78	45.4	15.95	
37	35.1	13.33	39.7	15.80	41.0	15.99	41.6	16.07	42.3	16.17	43.4	16.36	44.7	16.54	
39	35.1	14.18	39.0	15.97	40.3	16.52	41.0	16.62	41.6	16.73	42.9	16.91	44.1	17.12	
41	35.1	14.93	38.6	16.12	39.9	16.68	40.6	16.78	41.1	16.88	42.4	16.95	42.4	17.27	
43	35.1	15.31	38.3	16.20	39.6	16.72	40.4	16.86	40.7	16.91	41.7	16.98	41.9	17.31	
45	35.1	16.07	38.1	16.36	39.2	16.88	39.9	16.97	40.1	16.98	40.5	17.04	41.1	17.64	
48	35.1	16.62	38.0	16.88	38.6	17.02	39.3	17.11	39.6	17.16	39.5	17.33	40.2	17.70	
120%	-5	32.4	6.01	38.6	7.27	44.9	8.60	48.0	9.38	50.3	9.78	51.4	10.09	52.6	10.36
	-2	32.4	6.06	38.6	7.35	44.9	8.69	48.0	9.43	50.3	9.89	51.4	10.17	52.6	10.39
	0	32.4	6.12	38.6	7.40	44.9	8.79	48.0	9.46	50.3	9.98	51.4	10.24	52.6	10.42
	2	32.4	6.13	38.6	7.48	44.9	8.85	48.0	9.55	50.3	10.02	51.4	10.31	52.6	10.44
	4	32.4	6.20	38.6	7.57	44.9	8.97	48.0	9.63	50.3	10.15	51.4	10.33	52.6	10.46
	6	32.4	6.26	38.6	7.63	44.9	9.08	48.0	9.74	50.3	10.26	51.4	10.42	52.6	10.50
	8	32.4	6.32	38.6	7.71	44.9	9.20	48.0	9.87	50.3	10.37	51.4	10.45	52.6	10.55
	10	32.4	6.40	38.6	7.81	44.9	9.29	48.0	10.04	50.3	10.37	51.4	10.48	52.6	10.59
	12	32.4	6.52	38.6	7.95	44.9	9.47	48.0	10.23	49.6	10.42	50.7	10.42	51.9	10.66
	14	32.4	6.64	38.6	8.12	44.9	9.65	48.0	10.43	48.9	10.48	50.1	10.58	51.3	10.79
	16	32.4	6.76	38.6	8.28	44.9	9.84	47.7	10.62	48.3	10.64	49.4	10.76	50.6	10.95
	18	32.4	6.89	38.6	8.45	44.9	10.17	47.0	10.86	47.6	10.90	48.7	11.01	50.0	11.11
	20	32.4	7.03	38.6	8.77	44.9	10.95	46.4	11.40	47.0	11.44	48.1	11.54	49.3	11.64
	21	32.4	7.09	38.6	9.08	44.9	11.34	46.0	11.66	46.6	11.70	47.9	11.81	49.0	11.93
	23	32.4	7.58	38.6	9.74	44.9	12.13	45.4	12.18	46.0	12.24	47.1	12.36	48.3	12.46
	25	32.4	8.10	38.6	10.41	44.1	12.67	44.7	12.71	45.3	12.77	46.6	12.89	47.7	13.02
	27	32.4	8.65	38.6	11.13	43.6	13.18	44.1	13.26	44.7	13.32	45.9	13.45	47.0	13.57
	29	32.4	9.22	38.6	11.89	42.9	13.71	43.4	13.79	44.0	13.86	45.1	14.00	46.4	14.12
	31	32.4	9.84	38.6	12.69	42.1	14.27	42.9	14.33	43.4	14.41	44.6	14.55	45.7	14.70
	33	32.4	10.47	38.6	13.53	41.6	14.80	42.1	14.88	42.7	14.94	43.9	15.11	45.0	15.25
35	32.4	11.15	38.6	14.43	40.9	15.33	41.4	15.41	42.1	15.50	43.3	15.66	44.4	15.82	
37	32.4	11.87	38.6	15.37	40.3	15.89	40.9	15.97	41.4	16.05	42.6	16.21	43.7	16.40	
39	32.4	12.63	38.4	16.23	39.6	16.42	40.1	16.52	40.7	16.60	42.0	16.79	43.1	16.95	
41	32.4	12.97	38.1	16.35	39.3	16.54	39.8	16.64	40.4	16.72	41.7	16.83	41.9	17.08	
43	32.4	13.17	37.9	16.47	39.0	16.64	39.5	16.70	40.1	16.78	41.0	16.88	41.3	17.42	
45	32.4	13.32	37.7	16.62	38.6	16.79	39.1	16.86	39.7	16.91	40.1	16.93	40.8	17.80	
48	32.4	13.41	37.4	16.80	38.1	16.94	38.5	16.96	39.3	17.06	39.5	17.11	40.3	18.02	

Abbreviations:

CR: Combination ratio

TC: Total capacity (kW)

PI: Power input (compressor + outdoor fan motor) (kW)

Notes:

Shaded cells indicate rating condition.

Table continued on next page ...

Table 2-8.4: 14HP cooling capacity (continued)

Combination (%) (Capacity index)	Outdoor temperature (°C DB)	Indoor temperature(°C DB/WB)													
		DB:20.8,WB:14		DB:23.3,WB:16		DB:25.8,WB:18		DB:27,WB:19		DB:28.2,WB:20		DB:30.7,WB:22		DB:32,WB:24	
		TC kW	PI kW	TC kW	PI kW	TC kW	PI kW	TC kW	PI kW	TC kW	PI kW	TC kW	PI kW	TC kW	PI kW
110%	-5	29.7	5.24	35.4	6.53	41.1	7.79	44.0	8.36	46.9	9.00	50.4	9.34	51.6	9.63
	-2	29.7	5.34	35.4	6.61	41.1	7.86	44.0	8.44	46.9	9.07	50.4	9.44	51.6	9.68
	0	29.7	5.40	35.4	6.65	41.1	7.92	44.0	8.50	46.9	9.17	50.4	9.53	51.6	9.80
	2	29.7	5.52	35.4	6.71	41.1	8.04	44.0	8.59	46.9	9.27	50.4	9.67	51.6	9.92
	4	29.7	5.63	35.4	6.79	41.1	8.12	44.0	8.70	46.9	9.41	50.4	9.80	51.6	10.01
	6	29.7	5.68	35.4	6.87	41.1	8.19	44.0	8.84	46.9	9.51	50.4	9.90	51.6	10.17
	8	29.7	5.73	35.4	6.98	41.1	8.29	44.0	8.93	46.9	9.62	50.4	9.97	51.6	10.27
	10	29.7	5.80	35.4	7.07	41.1	8.41	44.0	9.08	46.9	9.78	50.4	10.04	51.6	10.36
	12	29.7	5.92	35.4	7.22	41.1	8.57	44.0	9.27	46.9	9.96	49.9	10.19	50.9	10.50
	14	29.7	6.03	35.4	7.34	41.1	8.73	44.0	9.43	46.9	10.15	49.1	10.27	50.3	10.57
	16	29.7	6.13	35.4	7.48	41.1	8.90	44.0	9.61	46.9	10.35	48.6	10.39	49.6	10.69
	18	29.7	6.25	35.4	7.63	41.1	9.08	44.0	9.88	46.9	10.84	47.9	10.93	49.0	11.03
	20	29.7	6.37	35.4	7.79	41.1	9.61	44.0	10.62	46.1	11.38	47.3	11.46	48.3	11.56
	21	29.7	6.44	35.4	8.01	41.1	9.96	44.0	11.01	45.9	11.64	46.9	11.72	48.0	11.83
	23	29.7	6.74	35.4	8.59	41.1	10.68	44.0	11.81	45.1	12.16	46.3	12.28	47.3	12.38
	25	29.7	7.20	35.4	9.18	41.1	11.42	44.0	12.65	44.6	12.69	45.6	12.81	46.7	12.91
	27	29.7	7.67	35.4	9.82	41.1	12.22	43.3	13.18	43.9	13.22	45.0	13.34	46.0	13.47
	29	29.7	8.18	35.4	10.48	41.1	13.06	42.7	13.71	43.3	13.78	44.3	13.90	45.4	14.02
	31	29.7	8.71	35.4	11.17	41.1	13.94	42.0	14.25	42.6	14.31	43.7	14.43	44.7	14.57
	33	29.7	9.27	35.4	11.91	40.9	14.70	41.4	14.78	42.0	14.84	43.0	14.98	44.1	15.13
35	29.7	9.86	35.4	12.69	40.1	15.23	40.7	15.31	41.3	15.40	42.3	15.54	43.4	15.68	
37	29.7	10.50	35.4	13.51	39.6	15.78	40.1	15.85	40.6	15.93	41.7	16.09	42.7	16.23	
39	29.7	11.15	35.4	14.39	38.9	16.32	39.4	16.40	40.0	16.48	41.0	16.64	42.1	16.81	
41	29.7	11.27	35.4	14.51	38.6	16.43	39.1	16.51	39.7	16.60	40.5	16.76	40.9	16.92	
43	29.7	11.38	35.4	14.69	38.2	16.55	38.8	16.63	39.4	16.71	40.1	16.82	40.2	17.27	
45	29.7	11.75	35.4	14.77	37.9	16.70	38.4	16.83	39.0	16.86	39.7	17.28	39.9	17.67	
48	29.7	12.14	35.4	15.99	37.3	16.78	37.8	16.91	38.6	17.01	39.1	17.31	39.4	17.82	
100%	-5	27.0	4.78	32.1	5.75	37.4	6.84	40.0	7.33	42.6	7.95	47.9	9.06	50.6	9.46
	-2	27.0	4.83	32.1	5.83	37.4	6.92	40.0	7.47	42.6	8.06	47.9	9.17	50.6	9.52
	0	27.0	4.88	32.1	5.89	37.4	7.00	40.0	7.56	42.6	8.14	47.9	9.32	50.6	9.63
	2	27.0	4.98	32.1	5.97	37.4	7.07	40.0	7.66	42.6	8.23	47.9	9.46	50.6	9.78
	4	27.0	5.02	32.1	6.02	37.4	7.18	40.0	7.77	42.6	8.33	47.9	9.55	50.6	9.89
	6	27.0	5.09	32.1	6.14	37.4	7.27	40.0	7.91	42.6	8.46	47.9	9.69	50.6	10.04
	8	27.0	5.19	32.1	6.24	37.4	7.40	40.0	8.00	42.6	8.59	47.9	9.84	50.6	10.21
	10	27.0	5.25	32.1	6.35	37.4	7.52	40.0	8.14	42.6	8.75	47.9	10.00	50.6	10.35
	12	27.0	5.33	32.1	6.48	37.4	7.67	40.0	8.28	42.6	8.92	47.9	10.19	49.9	10.43
	14	27.0	5.43	32.1	6.60	37.4	7.81	40.0	8.45	42.6	9.08	47.9	10.39	49.3	10.56
	16	27.0	5.53	32.1	6.72	37.4	7.97	40.0	8.61	42.6	9.27	47.6	10.52	48.6	10.68
	18	27.0	5.64	32.1	6.85	37.4	8.12	40.0	8.77	42.6	9.45	47.0	10.86	48.0	10.95
	20	27.0	5.74	32.1	6.99	37.4	8.36	40.0	9.22	42.6	10.13	46.3	11.38	47.3	11.48
	21	27.0	5.80	32.1	7.05	37.4	8.67	40.0	9.55	42.6	10.47	46.0	11.64	47.0	11.74
	23	27.0	5.94	32.1	7.52	37.4	9.29	40.0	10.23	42.6	11.23	45.4	12.17	46.3	12.28
	25	27.0	6.33	32.1	8.03	37.4	9.94	40.0	10.97	42.6	12.03	44.7	12.71	45.7	12.81
	27	27.0	6.76	32.1	8.57	37.4	10.62	40.0	11.72	42.6	12.87	44.0	13.24	45.0	13.36
	29	27.0	7.19	32.1	9.14	37.4	11.34	40.0	12.52	42.4	13.67	43.4	13.79	44.4	13.90
	31	27.0	7.67	32.1	9.76	37.4	12.09	40.0	13.36	41.9	14.21	42.7	14.33	43.7	14.45
	33	27.0	8.14	32.1	10.39	37.4	12.89	40.0	14.27	41.1	14.74	42.1	14.86	43.1	15.00
35	27.0	8.65	32.1	11.05	37.4	13.75	40.0	15.21	40.4	15.27	41.4	15.41	42.4	15.54	
37	27.0	9.20	32.1	11.77	37.4	14.66	39.3	15.74	39.9	15.82	40.9	15.97	41.7	16.09	
39	27.0	9.78	32.1	12.50	37.4	15.60	38.7	16.28	39.1	16.36	40.1	16.50	41.1	16.66	
41	27.0	10.23	32.1	12.96	37.4	16.17	38.1	16.39	38.8	16.61	39.4	16.89	40.5	17.01	
43	27.0	10.69	32.1	13.42	37.4	16.47	37.5	16.58	38.6	16.77	39.7	17.00	39.8	17.20	
45	27.0	11.30	32.1	14.02	37.4	16.75	36.7	16.81	38.4	17.07	39.3	17.26	39.0	17.43	
48	27.0	11.79	32.1	14.52	37.4	16.78	35.2	17.00	38.3	17.38	36.9	17.44	38.2	17.59	

Abbreviations:
 CR: Combination ratio
 TC: Total capacity (kW)
 PI: Power input (compressor + outdoor fan motor) (kW)

Notes:
 Shaded cells indicate rating condition.

Table continued on next page ...

Table 2-8.4: 14HP cooling capacity (continued)

Combination (%) (Capacity index)	Outdoor temperature (°C DB)	Indoor temperature(°C DB/WB)													
		DB:20.8,WB:14		DB:23.3,WB:16		DB:25.8,WB:18		DB:27,WB:19		DB:28.2,WB:20		DB:30.7,WB:22		DB:32,WB:24	
		TC kW	PI kW	TC kW	PI kW	TC kW	PI kW	TC kW	PI kW	TC kW	PI kW	TC kW	PI kW	TC kW	PI kW
90%	-5	24.3	4.22	29.0	5.07	33.7	5.98	36.0	6.52	38.3	6.94	43.0	7.98	47.7	9.14
	-2	24.3	4.26	29.0	5.12	33.7	6.06	36.0	6.61	38.3	7.02	43.0	8.06	47.7	9.23
	0	24.3	4.33	29.0	5.18	33.7	6.15	36.0	6.69	38.3	7.11	43.0	8.15	47.7	9.30
	2	24.3	4.39	29.0	5.25	33.7	6.21	36.0	6.80	38.3	7.23	43.0	8.32	47.7	9.43
	4	24.3	4.46	29.0	5.33	33.7	6.32	36.0	6.89	38.3	7.32	43.0	8.45	47.7	9.57
	6	24.3	4.52	29.0	5.43	33.7	6.43	36.0	7.02	38.3	7.44	43.0	8.58	47.7	9.73
	8	24.3	4.61	29.0	5.54	33.7	6.56	36.0	7.11	38.3	7.57	43.0	8.74	47.7	9.82
	10	24.3	4.69	29.0	5.66	33.7	6.68	36.0	7.21	38.3	7.75	43.0	8.85	47.7	9.98
	12	24.3	4.78	29.0	5.76	33.7	6.81	36.0	7.34	38.3	7.89	43.0	9.02	47.7	10.17
	14	24.3	4.86	29.0	5.86	33.7	6.93	36.0	7.48	38.3	8.03	43.0	9.18	47.7	10.35
	16	24.3	4.94	29.0	5.96	33.7	7.07	36.0	7.63	38.3	8.20	43.0	9.37	47.6	10.53
	18	24.3	5.02	29.0	6.09	33.7	7.19	36.0	7.77	38.3	8.36	43.0	9.55	47.0	10.86
	20	24.3	5.12	29.0	6.23	33.7	7.34	36.0	7.93	38.3	8.67	43.0	10.27	46.3	11.38
	21	24.3	5.17	29.0	6.27	33.7	7.46	36.0	8.20	38.3	8.98	43.0	10.64	46.0	11.64
	23	24.3	5.27	29.0	6.52	33.7	7.99	36.0	8.79	38.3	9.63	43.0	11.42	45.3	12.17
	25	24.3	5.55	29.0	6.97	33.7	8.55	36.0	9.41	38.3	10.29	43.0	12.22	44.7	12.71
	27	24.3	5.90	29.0	7.42	33.7	9.12	36.0	10.04	38.3	11.01	43.0	13.08	44.0	13.24
	29	24.3	6.29	29.0	7.91	33.7	9.74	36.0	10.72	38.3	11.77	42.6	13.67	43.4	13.77
	31	24.3	6.68	29.0	8.42	33.7	10.37	36.0	11.44	38.3	12.54	41.9	14.20	42.7	14.33
	33	24.3	7.09	29.0	8.96	33.7	11.07	36.0	12.19	38.3	13.38	41.3	14.76	42.1	14.86
35	24.3	7.54	29.0	9.53	33.7	11.78	36.0	12.99	38.3	14.27	40.6	15.29	41.4	15.41	
37	24.3	7.99	29.0	10.13	33.7	12.54	36.0	13.84	38.3	15.21	39.9	15.82	40.9	15.95	
39	24.3	8.49	29.0	10.78	33.7	13.34	36.0	14.74	38.3	16.19	39.3	16.38	40.1	16.50	
41	24.3	8.78	29.0	11.27	33.7	13.83	36.0	15.13	38.3	16.29	39.0	16.79	39.9	16.89	
43	24.3	9.20	29.0	11.76	33.7	14.32	36.0	15.52	38.3	16.64	38.8	17.01	39.5	17.15	
45	24.3	9.78	29.0	12.34	33.7	14.90	36.0	16.04	38.3	17.10	38.6	17.19	38.9	17.38	
48	24.3	10.33	29.0	12.91	33.7	15.46	36.0	16.24	38.3	17.25	38.3	17.43	37.9	17.61	
80%	-5	21.6	3.72	25.7	4.40	29.9	5.21	32.0	5.54	34.1	5.97	38.3	6.90	42.4	7.87
	-2	21.6	3.78	25.7	4.46	29.9	5.25	32.0	5.63	34.1	6.02	38.3	6.96	42.4	7.95
	0	21.6	3.84	25.7	4.51	29.9	5.32	32.0	5.69	34.1	6.13	38.3	7.06	42.4	8.06
	2	21.6	3.92	25.7	4.58	29.9	5.40	32.0	5.80	34.1	6.24	38.3	7.20	42.4	8.21
	4	21.6	3.98	25.7	4.65	29.9	5.50	32.0	5.93	34.1	6.35	38.3	7.33	42.4	8.32
	6	21.6	4.05	25.7	4.76	29.9	5.58	32.0	6.06	34.1	6.47	38.3	7.44	42.4	8.46
	8	21.6	4.13	25.7	4.87	29.9	5.71	32.0	6.16	34.1	6.61	38.3	7.55	42.4	8.63
	10	21.6	4.16	25.7	4.98	29.9	5.86	32.0	6.31	34.1	6.76	38.3	7.73	42.4	8.71
	12	21.6	4.22	25.7	5.06	29.9	5.96	32.0	6.44	34.1	6.91	38.3	7.87	42.4	8.88
	14	21.6	4.31	25.7	5.17	29.9	6.07	32.0	6.54	34.1	7.03	38.3	8.01	42.4	9.04
	16	21.6	4.37	25.7	5.25	29.9	6.19	32.0	6.66	34.1	7.15	38.3	8.18	42.4	9.20
	18	21.6	4.45	25.7	5.35	29.9	6.31	32.0	6.81	34.1	7.30	38.3	8.34	42.4	9.39
	20	21.6	4.53	25.7	5.45	29.9	6.44	32.0	6.93	34.1	7.44	38.3	8.65	42.4	10.04
	21	21.6	4.57	25.7	5.49	29.9	6.50	32.0	7.01	34.1	7.61	38.3	8.96	42.4	10.41
	23	21.6	4.65	25.7	5.62	29.9	6.81	32.0	7.46	34.1	8.14	38.3	9.59	42.4	11.17
	25	21.6	4.80	25.7	5.96	29.9	7.28	32.0	7.97	34.1	8.69	38.3	10.27	42.4	11.95
	27	21.6	5.10	25.7	6.35	29.9	7.75	32.0	8.51	34.1	9.29	38.3	10.97	42.4	12.79
	29	21.6	5.43	25.7	6.76	29.9	8.26	32.0	9.06	34.1	9.92	38.3	11.70	42.4	13.67
	31	21.6	5.76	25.7	7.19	29.9	8.79	32.0	9.65	34.1	10.58	38.3	12.50	41.7	14.21
	33	21.6	6.13	25.7	7.65	29.9	9.37	32.0	10.29	34.1	11.25	38.3	13.32	41.1	14.74
35	21.6	6.50	25.7	8.14	29.9	9.96	32.0	10.95	34.1	11.99	38.3	14.21	40.4	15.27	
37	21.6	6.89	25.7	8.63	29.9	10.60	32.0	11.66	34.1	12.77	38.3	15.15	39.9	15.80	
39	21.6	7.30	25.7	9.20	29.9	11.27	32.0	12.40	34.1	13.59	38.3	16.13	39.1	16.36	
41	21.6	7.46	25.7	9.29	29.9	11.44	32.0	12.73	34.1	13.84	38.3	16.54	38.9	16.65	
43	21.6	7.68	25.7	9.37	29.9	11.60	32.0	12.95	34.1	14.03	38.3	16.73	38.7	16.82	
45	21.6	7.90	25.7	9.48	29.9	11.83	32.0	13.22	34.1	14.27	38.3	16.92	38.2	17.10	
48	21.6	8.15	25.7	9.53	29.9	12.01	32.0	13.40	34.1	14.38	38.3	17.08	37.9	17.32	

Abbreviations:

CR: Combination ratio

TC: Total capacity (kW)

PI: Power input (compressor + outdoor fan motor) (kW)

Notes:

Shaded cells indicate rating condition.

Table continued on next page ...

Table 2-8.4: 14HP cooling capacity (continued)

Combination (%) (Capacity index)	Outdoor temperature (°C DB)	Indoor temperature(°C DB/WB)													
		DB:20.8,WB:14		DB:23.3,WB:16		DB:25.8,WB:18		DB:27,WB:19		DB:28.2,WB:20		DB:30.7,WB:22		DB:32,WB:24	
		TC kW	PI kW	TC kW	PI kW	TC kW	PI kW	TC kW	PI kW	TC kW	PI kW	TC kW	PI kW	TC kW	PI kW
70%	-5	18.9	3.32	22.6	3.90	26.1	4.41	28.0	4.73	29.9	5.05	33.4	5.78	37.1	6.64
	-2	18.9	3.35	22.6	3.91	26.1	4.44	28.0	4.82	29.9	5.14	33.4	5.87	37.1	6.73
	0	18.9	3.37	22.6	3.97	26.1	4.53	28.0	4.91	29.9	5.23	33.4	5.99	37.1	6.83
	2	18.9	3.39	22.6	3.99	26.1	4.61	28.0	5.01	29.9	5.32	33.4	6.12	37.1	6.94
	4	18.9	3.43	22.6	4.09	26.1	4.71	28.0	5.10	29.9	5.44	33.4	6.22	37.1	7.10
	6	18.9	3.49	22.6	4.16	26.1	4.82	28.0	5.26	29.9	5.57	33.4	6.33	37.1	7.24
	8	18.9	3.55	22.6	4.28	26.1	4.93	28.0	5.34	29.9	5.69	33.4	6.51	37.1	7.37
	10	18.9	3.62	22.6	4.35	26.1	5.06	28.0	5.45	29.9	5.84	33.4	6.64	37.1	7.46
	12	18.9	3.71	22.6	4.41	26.1	5.17	28.0	5.56	29.9	5.94	33.4	6.76	37.1	7.60
	14	18.9	3.77	22.6	4.49	26.1	5.25	28.0	5.64	29.9	6.05	33.4	6.89	37.1	7.75
	16	18.9	3.83	22.6	4.57	26.1	5.35	28.0	5.76	29.9	6.17	33.4	7.01	37.1	7.89
	18	18.9	3.89	22.6	4.65	26.1	5.45	28.0	5.86	29.9	6.27	33.4	7.15	37.1	8.06
	20	18.9	3.96	22.6	4.74	26.1	5.56	28.0	5.96	29.9	6.40	33.4	7.30	37.1	8.28
	21	18.9	4.00	22.6	4.78	26.1	5.60	28.0	6.03	29.9	6.46	33.4	7.40	37.1	8.57
	23	18.9	4.06	22.6	4.86	26.1	5.72	28.0	6.23	29.9	6.78	33.4	7.93	37.1	9.18
	25	18.9	4.14	22.6	5.06	26.1	6.09	28.0	6.66	29.9	7.24	33.4	8.49	37.1	9.82
	27	18.9	4.39	22.6	5.39	26.1	6.50	28.0	7.09	29.9	7.73	33.4	9.06	37.1	10.50
	29	18.9	4.65	22.6	5.72	26.1	6.91	28.0	7.56	29.9	8.22	33.4	9.65	37.1	11.21
	31	18.9	4.92	22.6	6.07	26.1	7.36	28.0	8.04	29.9	8.75	33.4	10.29	37.1	11.95
	33	18.9	5.23	22.6	6.46	26.1	7.83	28.0	8.55	29.9	9.33	33.4	10.97	37.1	12.75
35	18.9	5.53	22.6	6.85	26.1	8.30	28.0	9.10	29.9	9.92	33.4	11.68	37.1	13.59	
37	18.9	5.84	22.6	7.26	26.1	8.83	28.0	9.65	29.9	10.56	33.4	12.44	37.1	14.47	
39	18.9	6.19	22.6	7.69	26.1	9.37	28.0	10.27	29.9	11.21	33.4	13.22	37.1	15.41	
41	18.9	6.46	22.6	7.96	26.1	9.64	28.0	10.61	29.9	11.55	33.4	13.77	37.1	16.10	
43	18.9	6.99	22.6	8.51	26.1	10.04	28.0	11.18	29.9	11.90	33.4	14.27	37.1	16.60	
45	18.9	7.14	22.6	8.69	26.1	10.25	28.0	11.36	29.9	12.49	33.4	15.04	37.1	17.23	
48	18.9	7.28	22.6	8.74	26.1	10.38	28.0	11.56	29.9	12.83	33.4	15.74	37.1	17.66	
60%	-5	16.1	2.83	19.3	3.29	22.4	3.83	24.0	4.08	25.6	4.41	28.7	4.95	31.9	5.68
	-2	16.1	2.85	19.3	3.34	22.4	3.90	24.0	4.14	25.6	4.45	28.7	5.02	31.9	5.71
	0	16.1	2.89	19.3	3.38	22.4	3.95	24.0	4.19	25.6	4.53	28.7	5.10	31.9	5.79
	2	16.1	2.95	19.3	3.46	22.4	4.02	24.0	4.27	25.6	4.59	28.7	5.20	31.9	5.86
	4	16.1	3.03	19.3	3.52	22.4	4.10	24.0	4.33	25.6	4.65	28.7	5.28	31.9	5.94
	6	16.1	3.06	19.3	3.59	22.4	4.18	24.0	4.42	25.6	4.75	28.7	5.39	31.9	6.08
	8	16.1	3.12	19.3	3.65	22.4	4.26	24.0	4.50	25.6	4.84	28.7	5.49	31.9	6.18
	10	16.1	3.18	19.3	3.73	22.4	4.32	24.0	4.63	25.6	4.94	28.7	5.59	31.9	6.27
	12	16.1	3.24	19.3	3.79	22.4	4.41	24.0	4.71	25.6	5.02	28.7	5.70	31.9	6.37
	14	16.1	3.28	19.3	3.85	22.4	4.47	24.0	4.80	25.6	5.12	28.7	5.80	31.9	6.50
	16	16.1	3.32	19.3	3.91	22.4	4.55	24.0	4.88	25.6	5.21	28.7	5.90	31.9	6.62
	18	16.1	3.38	19.3	3.98	22.4	4.63	24.0	4.96	25.6	5.31	28.7	6.00	31.9	6.74
	20	16.1	3.42	19.3	4.06	22.4	4.71	24.0	5.06	25.6	5.41	28.7	6.13	31.9	6.89
	21	16.1	3.46	19.3	4.08	22.4	4.75	24.0	5.10	25.6	5.45	28.7	6.19	31.9	6.95
	23	16.1	3.50	19.3	4.16	22.4	4.84	24.0	5.21	25.6	5.55	28.7	6.44	31.9	7.40
	25	16.1	3.57	19.3	4.22	22.4	5.02	24.0	5.45	25.6	5.90	28.7	6.87	31.9	7.89
	27	16.1	3.71	19.3	4.49	22.4	5.35	24.0	5.82	25.6	6.29	28.7	7.32	31.9	8.42
	29	16.1	3.91	19.3	4.75	22.4	5.70	24.0	6.19	25.6	6.70	28.7	7.81	31.9	9.00
	31	16.1	4.16	19.3	5.04	22.4	6.05	24.0	6.58	25.6	7.13	28.7	8.30	31.9	9.57
	33	16.1	4.39	19.3	5.35	22.4	6.41	24.0	6.99	25.6	7.58	28.7	8.83	31.9	10.21
35	16.1	4.65	19.3	5.68	22.4	6.80	24.0	7.42	25.6	8.05	28.7	9.41	31.9	10.86	
37	16.1	4.92	19.3	6.00	22.4	7.21	24.0	7.87	25.6	8.55	28.7	10.00	31.9	11.56	
39	16.1	5.19	19.3	6.35	22.4	7.64	24.0	8.34	25.6	9.08	28.7	10.62	31.9	12.30	
41	16.1	5.35	19.3	6.63	22.4	7.92	24.0	8.68	25.6	9.41	28.7	11.12	31.9	12.85	
43	16.1	5.52	19.3	6.91	22.4	8.20	24.0	8.93	25.6	9.74	28.7	11.59	31.9	13.41	
45	16.1	5.78	19.3	7.26	22.4	8.53	24.0	9.27	25.6	10.22	28.7	12.11	31.9	14.15	
48	16.1	5.99	19.3	7.57	22.4	8.83	24.0	9.50	25.6	10.61	28.7	12.54	31.9	14.84	

Abbreviations:
 CR: Combination ratio
 TC: Total capacity (kW)
 PI: Power input (compressor + outdoor fan motor) (kW)

Notes:
 Shaded cells indicate rating condition.

Table continued on next page ...

Table 2-8.4: 14HP cooling capacity (continued)

Combination (%) (Capacity index)	Outdoor temperature (°C DB)	Indoor temperature(°C DB/WB)													
		DB:20.8,WB:14		DB:23.3,WB:16		DB:25.8,WB:18		DB:27,WB:19		DB:28.2,WB:20		DB:30.7,WB:22		DB:32,WB:24	
		TC kW	PI kW	TC kW	PI kW	TC kW	PI kW	TC kW	PI kW	TC kW	PI kW	TC kW	PI kW	TC kW	PI kW
50%	-5	13.5	2.46	16.1	2.85	18.7	3.27	20.0	3.42	21.3	3.61	23.9	4.11	26.6	4.43
	-2	13.5	2.48	16.1	2.90	18.7	3.31	20.0	3.47	21.3	3.68	23.9	4.16	26.6	4.49
	0	13.5	2.52	16.1	2.95	18.7	3.36	20.0	3.52	21.3	3.72	23.9	4.23	26.6	4.56
	2	13.5	2.56	16.1	2.99	18.7	3.42	20.0	3.57	21.3	3.78	23.9	4.25	26.6	4.65
	4	13.5	2.58	16.1	3.04	18.7	3.46	20.0	3.61	21.3	3.86	23.9	4.36	26.6	4.77
	6	13.5	2.63	16.1	3.09	18.7	3.51	20.0	3.70	21.3	3.93	23.9	4.42	26.6	4.91
	8	13.5	2.69	16.1	3.14	18.7	3.57	20.0	3.78	21.3	3.98	23.9	4.49	26.6	5.07
	10	13.5	2.75	16.1	3.18	18.7	3.63	20.0	3.84	21.3	4.10	23.9	4.61	26.6	5.14
	12	13.5	2.77	16.1	3.22	18.7	3.69	20.0	3.91	21.3	4.18	23.9	4.69	26.6	5.23
	14	13.5	2.81	16.1	3.26	18.7	3.73	20.0	4.00	21.3	4.24	23.9	4.78	26.6	5.33
	16	13.5	2.85	16.1	3.30	18.7	3.79	20.0	4.06	21.3	4.30	23.9	4.86	26.6	5.41
	18	13.5	2.89	16.1	3.36	18.7	3.85	20.0	4.12	21.3	4.39	23.9	4.94	26.6	5.51
	20	13.5	2.93	16.1	3.40	18.7	3.91	20.0	4.18	21.3	4.47	23.9	5.02	26.6	5.62
	21	13.5	2.95	16.1	3.44	18.7	3.96	20.0	4.22	21.3	4.51	23.9	5.08	26.6	5.68
	23	13.5	2.99	16.1	3.48	18.7	4.02	20.0	4.30	21.3	4.59	23.9	5.16	26.6	5.80
	25	13.5	3.03	16.1	3.55	18.7	4.10	20.0	4.39	21.3	4.73	23.9	5.43	26.6	6.19
	27	13.5	3.09	16.1	3.69	18.7	4.32	20.0	4.67	21.3	5.02	23.9	5.78	26.6	6.60
	29	13.5	3.26	16.1	3.89	18.7	4.59	20.0	4.96	21.3	5.35	23.9	6.15	26.6	7.03
	31	13.5	3.44	16.1	4.12	18.7	4.86	20.0	5.27	21.3	5.68	23.9	6.54	26.6	7.48
	33	13.5	3.65	16.1	4.37	18.7	5.16	20.0	5.57	21.3	6.03	23.9	6.95	26.6	7.95
35	13.5	3.85	16.1	4.61	18.7	5.45	20.0	5.90	21.3	6.37	23.9	7.38	26.6	8.44	
37	13.5	4.06	16.1	4.88	18.7	5.78	20.0	6.25	21.3	6.76	23.9	7.83	26.6	8.98	
39	13.5	4.28	16.1	5.14	18.7	6.11	20.0	6.62	21.3	7.17	23.9	8.30	26.6	9.53	
41	13.5	4.46	16.1	5.37	18.7	6.33	20.0	6.93	21.3	7.48	23.9	8.74	26.6	9.97	
43	13.5	4.76	16.1	5.73	18.7	6.55	20.0	7.24	21.3	7.68	23.9	9.19	26.6	10.42	
45	13.5	4.86	16.1	5.88	18.7	6.99	20.0	7.80	21.3	8.00	23.9	10.07	26.6	11.30	
48	13.5	4.96	16.1	6.02	18.7	7.38	20.0	8.32	21.3	8.38	23.9	10.86	26.6	12.16	

Abbreviations:

CR: Combination ratio

TC: Total capacity (kW)

PI: Power input (compressor + outdoor fan motor) (kW)

Notes:

Shaded cells indicate rating condition.

Table 2-8.5: 16HP cooling capacity

Combination (%) (Capacity index)	Outdoor temperature (°C DB)	Indoor temperature(°C DB/WB)													
		DB:20.8,WB:14		DB:23.3,WB:16		DB:25.8,WB:18		DB:27,WB:19		DB:28.2,WB:20		DB:30.7,WB:22		DB:32,WB:24	
		TC	PI	TC	PI	TC	PI	TC	PI	TC	PI	TC	PI	TC	PI
130%	-5	39.5	8.48	47.1	10.35	54.6	11.09	56.7	11.54	59.5	11.87	60.9	12.91	62.4	12.99
	-2	39.5	8.48	47.1	10.55	54.6	11.09	56.7	11.61	59.5	11.87	60.9	13.07	62.4	13.12
	0	39.5	8.62	47.1	10.73	54.6	11.50	56.7	12.25	59.5	12.56	60.9	13.23	62.4	13.29
	2	39.5	8.78	47.1	10.75	54.6	11.89	56.7	12.94	59.5	12.70	60.9	13.33	62.4	13.49
	4	39.5	8.97	47.1	10.96	54.6	12.30	56.7	12.99	59.5	12.87	60.9	13.53	62.4	13.75
	6	39.5	9.15	47.1	11.18	54.6	12.76	56.7	13.10	58.8	13.27	60.2	13.74	61.8	13.85
	8	39.5	9.36	47.1	11.44	54.6	13.40	56.7	13.74	58.1	13.70	59.5	13.78	61.0	13.98
	10	39.5	9.56	47.1	11.68	54.6	13.89	56.7	14.20	57.4	13.96	58.8	13.99	60.3	14.39
	12	39.5	9.73	47.1	11.91	54.6	14.17	55.9	14.41	56.7	14.17	58.0	14.21	59.5	14.48
	14	39.5	9.92	47.1	12.13	54.5	14.38	55.3	14.62	55.9	14.38	57.4	14.42	58.8	14.81
	16	39.5	10.09	47.1	12.38	53.8	14.59	54.5	14.81	55.1	14.80	56.6	14.63	58.0	15.04
	18	39.5	10.29	47.1	12.63	53.0	14.81	53.7	14.90	54.5	14.98	55.9	15.12	57.4	15.26
	20	39.5	10.51	47.1	13.44	52.2	15.54	53.0	15.62	53.7	15.71	55.1	15.85	56.6	16.01
	21	39.5	10.79	47.1	13.92	51.9	15.90	52.7	15.99	53.4	16.07	54.8	16.24	56.2	16.38
	23	39.5	11.57	47.1	14.93	51.3	16.63	51.9	16.71	52.6	16.80	54.0	16.96	55.4	17.13
	25	39.5	12.35	47.1	15.99	50.5	17.36	51.1	17.44	51.9	17.55	53.4	17.72	54.8	17.89
	27	39.5	13.19	47.1	17.11	49.8	18.08	50.5	18.19	51.1	18.28	52.6	18.48	54.0	18.67
	29	39.5	14.09	47.1	18.28	49.0	18.81	49.7	18.92	50.5	19.03	51.9	19.23	53.4	19.43
	31	39.5	15.04	46.9	19.34	48.2	19.57	49.0	19.68	49.7	19.76	51.1	19.98	52.6	20.21
	33	39.5	16.01	46.1	20.07	47.6	20.29	48.2	20.40	49.0	20.52	50.5	20.74	51.7	20.96
35	39.5	17.08	45.3	20.79	46.8	21.05	47.6	21.16	48.2	21.27	49.7	21.52	51.1	21.74	
37	39.5	18.17	44.7	21.55	46.1	21.80	46.8	21.91	47.6	22.05	48.9	22.31	50.3	22.56	
39	39.5	19.34	43.9	21.77	45.3	22.53	46.1	22.67	46.8	22.81	48.2	23.06	49.7	23.34	
41	39.5	20.36	43.4	21.99	44.8	22.74	45.6	22.88	46.3	23.02	47.7	23.10	47.8	23.55	
43	39.5	20.87	43.1	22.09	44.6	22.80	45.4	22.98	45.8	23.05	46.9	23.15	47.2	23.60	
45	39.5	21.91	42.8	22.30	44.1	23.01	44.9	23.13	45.1	23.16	45.6	23.23	46.3	24.05	
48	39.5	22.67	42.7	23.01	43.4	23.21	44.2	23.32	44.6	23.40	44.4	23.63	45.2	24.14	
120%	-5	36.5	8.19	43.4	9.92	50.5	11.73	54.0	12.79	56.6	13.33	57.9	13.76	59.1	14.12
	-2	36.5	8.27	43.4	10.02	50.5	11.84	54.0	12.86	56.6	13.49	57.9	13.87	59.1	14.17
	0	36.5	8.34	43.4	10.09	50.5	11.98	54.0	12.89	56.6	13.61	57.9	13.96	59.1	14.20
	2	36.5	8.36	43.4	10.19	50.5	12.06	54.0	13.02	56.6	13.66	57.9	14.06	59.1	14.23
	4	36.5	8.45	43.4	10.32	50.5	12.23	54.0	13.14	56.6	13.84	57.9	14.09	59.1	14.27
	6	36.5	8.54	43.4	10.40	50.5	12.38	54.0	13.28	56.6	13.99	57.9	14.20	59.1	14.31
	8	36.5	8.62	43.4	10.51	50.5	12.55	54.0	13.45	56.6	14.13	57.9	14.25	59.1	14.38
	10	36.5	8.72	43.4	10.65	50.5	12.66	54.0	13.69	56.6	14.14	57.9	14.29	59.1	14.45
	12	36.5	8.89	43.4	10.84	50.5	12.91	54.0	13.95	55.8	14.20	57.1	14.21	58.3	14.54
	14	36.5	9.06	43.4	11.07	50.5	13.16	54.0	14.23	55.0	14.29	56.4	14.43	57.7	14.71
	16	36.5	9.22	43.4	11.29	50.5	13.42	53.7	14.48	54.3	14.50	55.6	14.67	56.9	14.93
	18	36.5	9.39	43.4	11.52	50.5	13.86	52.9	14.81	53.5	14.87	54.8	15.01	56.2	15.15
	20	36.5	9.59	43.4	11.96	50.5	14.92	52.2	15.54	52.9	15.59	54.2	15.74	55.4	15.87
	21	36.5	9.67	43.4	12.38	50.5	15.46	51.7	15.90	52.4	15.96	53.8	16.10	55.1	16.27
	23	36.5	10.34	43.4	13.27	50.5	16.54	51.1	16.60	51.7	16.69	53.0	16.85	54.3	16.99
	25	36.5	11.04	43.4	14.20	49.7	17.27	50.3	17.33	50.9	17.41	52.4	17.58	53.7	17.75
	27	36.5	11.79	43.4	15.18	49.0	17.97	49.7	18.08	50.3	18.17	51.6	18.33	52.9	18.50
	29	36.5	12.58	43.4	16.21	48.2	18.70	48.9	18.81	49.5	18.89	50.8	19.09	52.2	19.26
	31	36.5	13.42	43.4	17.30	47.4	19.45	48.2	19.54	48.9	19.65	50.1	19.84	51.4	20.04
	33	36.5	14.28	43.4	18.45	46.8	20.18	47.4	20.29	48.1	20.37	49.3	20.60	50.6	20.79
35	36.5	15.20	43.4	19.68	46.0	20.90	46.6	21.02	47.4	21.13	48.7	21.35	50.0	21.58	
37	36.5	16.18	43.4	20.96	45.3	21.66	46.0	21.77	46.6	21.88	47.9	22.11	49.2	22.36	
39	36.5	17.22	43.2	22.14	44.5	22.39	45.2	22.53	45.8	22.64	47.2	22.89	48.5	23.11	
41	36.5	17.69	42.9	22.29	44.2	22.55	44.8	22.68	45.5	22.80	46.9	22.95	47.1	23.29	
43	36.5	17.95	42.7	22.45	43.8	22.68	44.5	22.77	45.1	22.88	46.1	23.02	46.4	23.75	
45	36.5	18.16	42.4	22.66	43.4	22.89	44.0	22.98	44.7	23.05	45.2	23.09	45.9	24.27	
48	36.5	18.29	42.1	22.91	42.8	23.09	43.3	23.12	44.2	23.27	44.5	23.33	45.3	24.57	

Abbreviations:

CR: Combination ratio

TC: Total capacity (kW)

PI: Power input (compressor + outdoor fan motor) (kW)

Notes:

Shaded cells indicate rating condition.

Table continued on next page ...

Table 2-8.5: 16HP cooling capacity (continued)

Combination (%) (Capacity index)	Outdoor temperature (°C DB)	Indoor temperature(°C DB/WB)													
		DB:20.8,WB:14		DB:23.3,WB:16		DB:25.8,WB:18		DB:27,WB:19		DB:28.2,WB:20		DB:30.7,WB:22		DB:32,WB:24	
		TC	PI	TC	PI	TC	PI	TC	PI	TC	PI	TC	PI	TC	PI
110%	-5	33.4	7.15	39.9	8.90	46.3	10.62	49.5	11.40	52.7	12.27	56.7	12.74	58.0	13.13
	-2	33.4	7.29	39.9	9.02	46.3	10.71	49.5	11.51	52.7	12.36	56.7	12.87	58.0	13.20
	0	33.4	7.36	39.9	9.07	46.3	10.79	49.5	11.59	52.7	12.50	56.7	12.99	58.0	13.36
	2	33.4	7.52	39.9	9.15	46.3	10.96	49.5	11.71	52.7	12.63	56.7	13.18	58.0	13.53
	4	33.4	7.67	39.9	9.26	46.3	11.07	49.5	11.86	52.7	12.83	56.7	13.36	58.0	13.65
	6	33.4	7.75	39.9	9.36	46.3	11.17	49.5	12.05	52.7	12.97	56.7	13.50	58.0	13.86
	8	33.4	7.82	39.9	9.51	46.3	11.30	49.5	12.17	52.7	13.12	56.7	13.59	58.0	14.01
	10	33.4	7.91	39.9	9.64	46.3	11.46	49.5	12.38	52.7	13.33	56.7	13.69	58.0	14.13
	12	33.4	8.08	39.9	9.84	46.3	11.68	49.5	12.63	52.7	13.58	56.1	13.89	57.2	14.31
	14	33.4	8.22	39.9	10.01	46.3	11.91	49.5	12.86	52.7	13.84	55.3	14.00	56.6	14.42
	16	33.4	8.36	39.9	10.20	46.3	12.13	49.5	13.11	52.7	14.11	54.6	14.17	55.8	14.57
	18	33.4	8.52	39.9	10.40	46.3	12.38	49.5	13.47	52.7	14.79	53.8	14.90	55.1	15.04
	20	33.4	8.69	39.9	10.62	46.3	13.11	49.5	14.48	51.9	15.51	53.2	15.62	54.3	15.76
	21	33.4	8.78	39.9	10.93	46.3	13.58	49.5	15.01	51.6	15.88	52.7	15.99	54.0	16.13
	23	33.4	9.19	39.9	11.71	46.3	14.56	49.5	16.10	50.8	16.57	52.1	16.74	53.2	16.88
	25	33.4	9.81	39.9	12.52	46.3	15.57	49.5	17.25	50.1	17.30	51.3	17.47	52.6	17.61
	27	33.4	10.45	39.9	13.39	46.3	16.66	48.7	17.97	49.3	18.03	50.6	18.20	51.8	18.36
	29	33.4	11.15	39.9	14.28	46.3	17.80	48.1	18.70	48.7	18.78	49.8	18.95	51.1	19.12
	31	33.4	11.88	39.9	15.23	46.3	19.01	47.3	19.43	47.9	19.51	49.2	19.68	50.3	19.87
	33	33.4	12.63	39.9	16.24	46.0	20.04	46.6	20.15	47.3	20.24	48.4	20.43	49.7	20.63
35	33.4	13.44	39.9	17.30	45.2	20.77	45.8	20.88	46.4	20.99	47.6	21.19	48.9	21.38	
37	33.4	14.31	39.9	18.42	44.5	21.52	45.2	21.60	45.6	21.72	46.9	21.94	48.1	22.14	
39	33.4	15.20	39.9	19.62	43.7	22.25	44.4	22.36	45.0	22.47	46.1	22.69	47.4	22.92	
41	33.4	15.36	39.9	19.78	43.4	22.40	44.0	22.52	44.7	22.63	45.5	22.85	46.0	23.07	
43	33.4	15.52	39.9	20.03	43.0	22.56	43.7	22.67	44.3	22.78	45.1	22.93	45.3	23.54	
45	33.4	16.02	39.9	20.14	42.6	22.77	43.2	22.95	43.9	22.99	44.7	23.56	44.9	24.09	
48	33.4	16.55	39.9	21.81	42.0	22.87	42.5	23.06	43.4	23.20	43.9	23.60	44.3	24.30	
100%	-5	30.4	6.51	36.2	7.84	42.1	9.33	45.0	10.00	47.9	10.85	53.8	12.36	56.9	12.90
	-2	30.4	6.59	36.2	7.94	42.1	9.44	45.0	10.18	47.9	10.99	53.8	12.50	56.9	12.98
	0	30.4	6.66	36.2	8.03	42.1	9.54	45.0	10.31	47.9	11.09	53.8	12.71	56.9	13.13
	2	30.4	6.79	36.2	8.14	42.1	9.64	45.0	10.44	47.9	11.22	53.8	12.90	56.9	13.33
	4	30.4	6.84	36.2	8.21	42.1	9.79	45.0	10.60	47.9	11.36	53.8	13.02	56.9	13.48
	6	30.4	6.94	36.2	8.38	42.1	9.91	45.0	10.78	47.9	11.53	53.8	13.21	56.9	13.69
	8	30.4	7.07	36.2	8.50	42.1	10.09	45.0	10.91	47.9	11.72	53.8	13.42	56.9	13.91
	10	30.4	7.15	36.2	8.66	42.1	10.26	45.0	11.09	47.9	11.93	53.8	13.64	56.9	14.11
	12	30.4	7.27	36.2	8.83	42.1	10.45	45.0	11.29	47.9	12.16	53.8	13.89	56.1	14.22
	14	30.4	7.41	36.2	9.00	42.1	10.65	45.0	11.52	47.9	12.38	53.8	14.17	55.4	14.40
	16	30.4	7.55	36.2	9.17	42.1	10.87	45.0	11.74	47.9	12.63	53.5	14.34	54.6	14.56
	18	30.4	7.69	36.2	9.33	42.1	11.07	45.0	11.96	47.9	12.88	52.9	14.81	54.0	14.92
	20	30.4	7.83	36.2	9.53	42.1	11.40	45.0	12.58	47.9	13.81	52.1	15.51	53.2	15.65
	21	30.4	7.91	36.2	9.61	42.1	11.82	45.0	13.02	47.9	14.28	51.8	15.87	52.9	16.01
	23	30.4	8.10	36.2	10.26	42.1	12.66	45.0	13.95	47.9	15.31	51.1	16.60	52.1	16.74
	25	30.4	8.64	36.2	10.96	42.1	13.55	45.0	14.95	47.9	16.41	50.3	17.33	51.4	17.47
	27	30.4	9.22	36.2	11.68	42.1	14.48	45.0	15.99	47.9	17.55	49.5	18.05	50.6	18.22
	29	30.4	9.81	36.2	12.47	42.1	15.46	45.0	17.08	47.7	18.64	48.9	18.81	50.0	18.95
	31	30.4	10.45	36.2	13.30	42.1	16.49	45.0	18.22	47.1	19.37	48.1	19.53	49.2	19.70
	33	30.4	11.09	36.2	14.17	42.1	17.58	45.0	19.45	46.3	20.09	47.4	20.26	48.5	20.46
35	30.4	11.79	36.2	15.06	42.1	18.75	45.0	20.74	45.5	20.82	46.6	21.02	47.7	21.19	
37	30.4	12.55	36.2	16.04	42.1	19.98	44.2	21.46	44.8	21.58	46.0	21.77	46.9	21.94	
39	30.4	13.33	36.2	17.05	42.1	21.27	43.6	22.19	44.0	22.30	45.2	22.50	46.3	22.72	
41	30.4	13.95	36.2	17.67	42.1	22.05	42.9	22.35	43.7	22.65	44.4	23.03	45.6	23.19	
43	30.4	14.57	36.2	18.29	42.1	22.45	42.2	22.61	43.4	22.86	44.6	23.18	44.8	23.45	
45	30.4	15.40	36.2	19.12	42.1	22.84	41.3	22.92	43.2	23.28	44.3	23.53	43.9	23.76	
48	30.4	16.08	36.2	19.79	42.1	22.88	39.6	23.18	43.1	23.69	41.6	23.78	42.9	23.98	

Abbreviations:

CR: Combination ratio

TC: Total capacity (kW)

PI: Power input (compressor + outdoor fan motor) (kW)

Notes:

Shaded cells indicate rating condition.

Table continued on next page ...

Table 2-8.5: 16HP cooling capacity (continued)

Combination (%) (Capacity index)	Outdoor temperature (°C DB)	Indoor temperature(°C DB/WB)													
		DB:20.8,WB:14		DB:23.3,WB:16		DB:25.8,WB:18		DB:27,WB:19		DB:28.2,WB:20		DB:30.7,WB:22		DB:32,WB:24	
		TC kW	PI kW	TC kW	PI kW	TC kW	PI kW	TC kW	PI kW	TC kW	PI kW	TC kW	PI kW	TC kW	PI kW
90%	-5	27.3	5.76	32.6	6.91	37.9	8.15	40.5	8.89	43.1	9.46	48.4	10.88	53.7	12.46
	-2	27.3	5.81	32.6	6.98	37.9	8.26	40.5	9.02	43.1	9.58	48.4	10.99	53.7	12.58
	0	27.3	5.90	32.6	7.07	37.9	8.38	40.5	9.12	43.1	9.70	48.4	11.11	53.7	12.68
	2	27.3	5.99	32.6	7.16	37.9	8.47	40.5	9.27	43.1	9.85	48.4	11.34	53.7	12.86
	4	27.3	6.08	32.6	7.26	37.9	8.61	40.5	9.39	43.1	9.98	48.4	11.52	53.7	13.05
	6	27.3	6.16	32.6	7.41	37.9	8.77	40.5	9.57	43.1	10.15	48.4	11.70	53.7	13.27
	8	27.3	6.28	32.6	7.55	37.9	8.95	40.5	9.69	43.1	10.33	48.4	11.91	53.7	13.39
	10	27.3	6.40	32.6	7.71	37.9	9.11	40.5	9.84	43.1	10.56	48.4	12.07	53.7	13.61
	12	27.3	6.51	32.6	7.85	37.9	9.28	40.5	10.00	43.1	10.76	48.4	12.30	53.7	13.86
	14	27.3	6.62	32.6	7.99	37.9	9.45	40.5	10.20	43.1	10.96	48.4	12.52	53.7	14.11
	16	27.3	6.73	32.6	8.13	37.9	9.64	40.5	10.40	43.1	11.18	48.4	12.77	53.5	14.36
	18	27.3	6.85	32.6	8.30	37.9	9.81	40.5	10.59	43.1	11.40	48.4	13.02	52.9	14.81
	20	27.3	6.99	32.6	8.49	37.9	10.01	40.5	10.82	43.1	11.82	48.4	14.00	52.1	15.51
	21	27.3	7.04	32.6	8.55	37.9	10.17	40.5	11.18	43.1	12.24	48.4	14.50	51.8	15.87
	23	27.3	7.18	32.6	8.89	37.9	10.90	40.5	11.99	43.1	13.13	48.4	15.57	50.9	16.60
	25	27.3	7.57	32.6	9.50	37.9	11.65	40.5	12.83	43.1	14.03	48.4	16.66	50.3	17.33
	27	27.3	8.05	32.6	10.12	37.9	12.44	40.5	13.69	43.1	15.01	48.4	17.83	49.5	18.05
	29	27.3	8.58	32.6	10.79	37.9	13.27	40.5	14.62	43.1	16.04	47.9	18.64	48.9	18.78
	31	27.3	9.11	32.6	11.49	37.9	14.14	40.5	15.59	43.1	17.10	47.1	19.37	48.1	19.53
	33	27.3	9.67	32.6	12.21	37.9	15.09	40.5	16.63	43.1	18.25	46.4	20.12	47.4	20.26
35	27.3	10.28	32.6	12.99	37.9	16.07	40.5	17.72	43.1	19.45	45.6	20.85	46.6	21.02	
37	27.3	10.90	32.6	13.81	37.9	17.10	40.5	18.86	43.1	20.74	44.8	21.58	46.0	21.74	
39	27.3	11.57	32.6	14.70	37.9	18.19	40.5	20.09	43.1	22.08	44.2	22.33	45.2	22.50	
41	27.3	11.97	32.6	15.37	37.9	18.86	40.5	20.63	43.1	22.21	43.9	22.90	44.9	23.03	
43	27.3	12.54	32.6	16.03	37.9	19.52	40.5	21.16	43.1	22.68	43.7	23.20	44.5	23.39	
45	27.3	13.34	32.6	16.83	37.9	20.32	40.5	21.87	43.1	23.31	43.4	23.44	43.8	23.70	
48	27.3	14.08	32.6	17.60	37.9	21.08	40.5	22.14	43.1	23.51	43.1	23.77	42.6	24.02	
80%	-5	24.3	5.07	28.9	6.00	33.6	7.10	36.0	7.55	38.4	8.13	43.1	9.40	47.7	10.73
	-2	24.3	5.15	28.9	6.07	33.6	7.16	36.0	7.67	38.4	8.21	43.1	9.49	47.7	10.84
	0	24.3	5.24	28.9	6.15	33.6	7.25	36.0	7.76	38.4	8.36	43.1	9.63	47.7	10.98
	2	24.3	5.34	28.9	6.24	33.6	7.36	36.0	7.91	38.4	8.51	43.1	9.82	47.7	11.19
	4	24.3	5.43	28.9	6.34	33.6	7.50	36.0	8.09	38.4	8.66	43.1	10.00	47.7	11.34
	6	24.3	5.52	28.9	6.49	33.6	7.61	36.0	8.27	38.4	8.82	43.1	10.15	47.7	11.54
	8	24.3	5.63	28.9	6.64	33.6	7.79	36.0	8.40	38.4	9.01	43.1	10.30	47.7	11.76
	10	24.3	5.67	28.9	6.79	33.6	7.99	36.0	8.61	38.4	9.22	43.1	10.54	47.7	11.88
	12	24.3	5.76	28.9	6.90	33.6	8.13	36.0	8.78	38.4	9.42	43.1	10.73	47.7	12.10
	14	24.3	5.87	28.9	7.04	33.6	8.27	36.0	8.92	38.4	9.59	43.1	10.93	47.7	12.32
	16	24.3	5.95	28.9	7.15	33.6	8.44	36.0	9.08	38.4	9.75	43.1	11.15	47.7	12.55
	18	24.3	6.07	28.9	7.30	33.6	8.61	36.0	9.28	38.4	9.95	43.1	11.38	47.7	12.80
	20	24.3	6.18	28.9	7.43	33.6	8.78	36.0	9.45	38.4	10.15	43.1	11.79	47.7	13.69
	21	24.3	6.23	28.9	7.49	33.6	8.86	36.0	9.56	38.4	10.37	43.1	12.21	47.7	14.20
	23	24.3	6.34	28.9	7.66	33.6	9.28	36.0	10.17	38.4	11.09	43.1	13.08	47.7	15.23
	25	24.3	6.54	28.9	8.13	33.6	9.92	36.0	10.87	38.4	11.85	43.1	14.00	47.7	16.29
	27	24.3	6.96	28.9	8.66	33.6	10.57	36.0	11.60	38.4	12.66	43.1	14.95	47.7	17.44
	29	24.3	7.41	28.9	9.22	33.6	11.26	36.0	12.35	38.4	13.53	43.1	15.96	47.7	18.64
	31	24.3	7.85	28.9	9.81	33.6	11.99	36.0	13.16	38.4	14.42	43.1	17.05	46.9	19.37
	33	24.3	8.36	28.9	10.42	33.6	12.77	36.0	14.03	38.4	15.34	43.1	18.17	46.3	20.09
35	24.3	8.86	28.9	11.09	33.6	13.58	36.0	14.92	38.4	16.35	43.1	19.37	45.5	20.82	
37	24.3	9.39	28.9	11.77	33.6	14.45	36.0	15.90	38.4	17.41	43.1	20.65	44.8	21.55	
39	24.3	9.95	28.9	12.55	33.6	15.37	36.0	16.91	38.4	18.53	43.1	22.00	44.0	22.30	
41	24.3	10.17	28.9	12.66	33.6	15.60	36.0	17.36	38.4	18.87	43.1	22.56	43.8	22.70	
43	24.3	10.47	28.9	12.77	33.6	15.82	36.0	17.66	38.4	19.13	43.1	22.82	43.5	22.94	
45	24.3	10.77	28.9	12.92	33.6	16.13	36.0	18.03	38.4	19.46	43.1	23.07	43.0	23.32	
48	24.3	11.12	28.9	13.00	33.6	16.37	36.0	18.27	38.4	19.61	43.1	23.28	42.6	23.61	

Abbreviations:
 CR: Combination ratio
 TC: Total capacity (kW)
 PI: Power input (compressor + outdoor fan motor) (kW)

Notes:
 Shaded cells indicate rating condition.

Table continued on next page ...

Table 2-8.5: 16HP cooling capacity (continued)

Combination (%) (Capacity index)	Outdoor temperature (°C DB)	Indoor temperature(°C DB/WB)													
		DB:20.8,WB:14		DB:23.3,WB:16		DB:25.8,WB:18		DB:27,WB:19		DB:28.2,WB:20		DB:30.7,WB:22		DB:32,WB:24	
		TC kW	PI kW	TC kW	PI kW	TC kW	PI kW	TC kW	PI kW	TC kW	PI kW	TC kW	PI kW	TC kW	PI kW
70%	-5	21.2	4.53	25.4	5.31	29.4	6.02	31.5	6.45	33.6	6.89	37.6	7.88	41.8	9.06
	-2	21.2	4.57	25.4	5.34	29.4	6.06	31.5	6.58	33.6	7.01	37.6	8.00	41.8	9.18
	0	21.2	4.59	25.4	5.41	29.4	6.18	31.5	6.70	33.6	7.14	37.6	8.17	41.8	9.31
	2	21.2	4.62	25.4	5.44	29.4	6.28	31.5	6.83	33.6	7.26	37.6	8.34	41.8	9.46
	4	21.2	4.68	25.4	5.57	29.4	6.42	31.5	6.95	33.6	7.42	37.6	8.48	41.8	9.68
	6	21.2	4.75	25.4	5.67	29.4	6.58	31.5	7.17	33.6	7.59	37.6	8.62	41.8	9.87
	8	21.2	4.84	25.4	5.83	29.4	6.73	31.5	7.28	33.6	7.76	37.6	8.87	41.8	10.05
	10	21.2	4.94	25.4	5.93	29.4	6.90	31.5	7.43	33.6	7.97	37.6	9.06	41.8	10.17
	12	21.2	5.06	25.4	6.01	29.4	7.04	31.5	7.57	33.6	8.11	37.6	9.22	41.8	10.37
	14	21.2	5.14	25.4	6.12	29.4	7.16	31.5	7.69	33.6	8.24	37.6	9.39	41.8	10.57
	16	21.2	5.23	25.4	6.23	29.4	7.29	31.5	7.85	33.6	8.41	37.6	9.56	41.8	10.76
	18	21.2	5.31	25.4	6.34	29.4	7.43	31.5	7.99	33.6	8.55	37.6	9.75	41.8	10.98
	20	21.2	5.39	25.4	6.46	29.4	7.57	31.5	8.13	33.6	8.72	37.6	9.95	41.8	11.29
	21	21.2	5.45	25.4	6.51	29.4	7.63	31.5	8.22	33.6	8.80	37.6	10.09	41.8	11.68
	23	21.2	5.53	25.4	6.62	29.4	7.80	31.5	8.50	33.6	9.25	37.6	10.82	41.8	12.52
	25	21.2	5.65	25.4	6.90	29.4	8.30	31.5	9.08	33.6	9.87	37.6	11.57	41.8	13.39
	27	21.2	5.98	25.4	7.35	29.4	8.86	31.5	9.67	33.6	10.54	37.6	12.35	41.8	14.31
	29	21.2	6.34	25.4	7.80	29.4	9.42	31.5	10.31	33.6	11.21	37.6	13.16	41.8	15.29
	31	21.2	6.71	25.4	8.27	29.4	10.03	31.5	10.96	33.6	11.93	37.6	14.03	41.8	16.29
	33	21.2	7.13	25.4	8.80	29.4	10.68	31.5	11.65	33.6	12.72	37.6	14.95	41.8	17.38
35	21.2	7.55	25.4	9.34	29.4	11.32	31.5	12.41	33.6	13.53	37.6	15.93	41.8	18.53	
37	21.2	7.97	25.4	9.89	29.4	12.05	31.5	13.16	33.6	14.39	37.6	16.96	41.8	19.73	
39	21.2	8.44	25.4	10.48	29.4	12.77	31.5	14.00	33.6	15.29	37.6	18.03	41.8	21.02	
41	21.2	8.81	25.4	10.85	29.4	13.15	31.5	14.47	33.6	15.75	37.6	18.77	41.8	21.95	
43	21.2	9.53	25.4	11.60	29.4	13.69	31.5	15.24	33.6	16.22	37.6	19.45	41.8	22.63	
45	21.2	9.74	25.4	11.85	29.4	13.97	31.5	15.49	33.6	17.03	37.6	20.51	41.8	23.50	
48	21.2	9.93	25.4	11.91	29.4	14.15	31.5	15.76	33.6	17.50	37.6	21.47	41.8	24.07	
60%	-5	18.2	3.86	21.7	4.48	25.2	5.22	27.0	5.56	28.8	6.01	32.3	6.75	35.8	7.74
	-2	18.2	3.88	21.7	4.55	25.2	5.32	27.0	5.64	28.8	6.07	32.3	6.85	35.8	7.79
	0	18.2	3.95	21.7	4.61	25.2	5.39	27.0	5.72	28.8	6.17	32.3	6.95	35.8	7.89
	2	18.2	4.02	21.7	4.71	25.2	5.49	27.0	5.83	28.8	6.25	32.3	7.09	35.8	7.99
	4	18.2	4.13	21.7	4.80	25.2	5.59	27.0	5.90	28.8	6.35	32.3	7.20	35.8	8.10
	6	18.2	4.17	21.7	4.90	25.2	5.70	27.0	6.03	28.8	6.47	32.3	7.35	35.8	8.29
	8	18.2	4.25	21.7	4.98	25.2	5.81	27.0	6.14	28.8	6.61	32.3	7.49	35.8	8.43
	10	18.2	4.33	21.7	5.09	25.2	5.90	27.0	6.32	28.8	6.73	32.3	7.63	35.8	8.55
	12	18.2	4.42	21.7	5.17	25.2	6.01	27.0	6.43	28.8	6.85	32.3	7.77	35.8	8.69
	14	18.2	4.47	21.7	5.25	25.2	6.09	27.0	6.54	28.8	6.99	32.3	7.91	35.8	8.86
	16	18.2	4.53	21.7	5.34	25.2	6.20	27.0	6.65	28.8	7.10	32.3	8.05	35.8	9.03
	18	18.2	4.61	21.7	5.42	25.2	6.32	27.0	6.76	28.8	7.24	32.3	8.19	35.8	9.19
	20	18.2	4.67	21.7	5.53	25.2	6.43	27.0	6.90	28.8	7.38	32.3	8.36	35.8	9.39
	21	18.2	4.72	21.7	5.56	25.2	6.48	27.0	6.96	28.8	7.43	32.3	8.44	35.8	9.47
	23	18.2	4.78	21.7	5.67	25.2	6.59	27.0	7.10	28.8	7.57	32.3	8.77	35.8	10.09
	25	18.2	4.86	21.7	5.76	25.2	6.85	27.0	7.43	28.8	8.05	32.3	9.36	35.8	10.76
	27	18.2	5.06	21.7	6.12	25.2	7.29	27.0	7.94	28.8	8.58	32.3	9.98	35.8	11.48
	29	18.2	5.34	21.7	6.48	25.2	7.77	27.0	8.44	28.8	9.14	32.3	10.65	35.8	12.27
	31	18.2	5.67	21.7	6.87	25.2	8.24	27.0	8.97	28.8	9.72	32.3	11.32	35.8	13.05
	33	18.2	5.98	21.7	7.29	25.2	8.75	27.0	9.53	28.8	10.34	32.3	12.04	35.8	13.92
35	18.2	6.34	21.7	7.74	25.2	9.28	27.0	10.12	28.8	10.98	32.3	12.83	35.8	14.81	
37	18.2	6.71	21.7	8.19	25.2	9.84	27.0	10.73	28.8	11.65	32.3	13.64	35.8	15.76	
39	18.2	7.07	21.7	8.66	25.2	10.42	27.0	11.37	28.8	12.38	32.3	14.47	35.8	16.77	
41	18.2	7.30	21.7	9.04	25.2	10.80	27.0	11.83	28.8	12.83	32.3	15.16	35.8	17.53	
43	18.2	7.53	21.7	9.42	25.2	11.18	27.0	12.18	28.8	13.28	32.3	15.80	35.8	18.28	
45	18.2	7.88	21.7	9.90	25.2	11.64	27.0	12.64	28.8	13.94	32.3	16.51	35.8	19.30	
48	18.2	8.17	21.7	10.32	25.2	12.04	27.0	12.95	28.8	14.47	32.3	17.10	35.8	20.23	

Abbreviations:

CR: Combination ratio

TC: Total capacity (kW)

PI: Power input (compressor + outdoor fan motor) (kW)

Notes:

Shaded cells indicate rating condition.

Table continued on next page ...

Table 2-8.5: 16HP cooling capacity (continued)

Combination (%) (Capacity index)	Outdoor temperature (°C DB)	Indoor temperature(°C DB/WB)													
		DB:20.8,WB:14		DB:23.3,WB:16		DB:25.8,WB:18		DB:27,WB:19		DB:28.2,WB:20		DB:30.7,WB:22		DB:32,WB:24	
		TC	PI	TC	PI	TC	PI	TC	PI	TC	PI	TC	PI	TC	PI
		kW	kW	kW	kW	kW	kW	kW	kW	kW	kW	kW	kW	kW	kW
50%	-5	15.2	3.36	18.2	3.88	21.1	4.46	22.5	4.67	23.9	4.93	26.8	5.60	29.9	6.04
	-2	15.2	3.38	18.2	3.96	21.1	4.51	22.5	4.73	23.9	5.01	26.8	5.67	29.9	6.12
	0	15.2	3.44	18.2	4.02	21.1	4.59	22.5	4.80	23.9	5.07	26.8	5.77	29.9	6.22
	2	15.2	3.48	18.2	4.07	21.1	4.67	22.5	4.87	23.9	5.16	26.8	5.79	29.9	6.34
	4	15.2	3.52	18.2	4.14	21.1	4.72	22.5	4.93	23.9	5.26	26.8	5.94	29.9	6.50
	6	15.2	3.58	18.2	4.21	21.1	4.79	22.5	5.04	23.9	5.36	26.8	6.03	29.9	6.70
	8	15.2	3.67	18.2	4.28	21.1	4.87	22.5	5.15	23.9	5.43	26.8	6.13	29.9	6.91
	10	15.2	3.74	18.2	4.33	21.1	4.95	22.5	5.23	23.9	5.59	26.8	6.29	29.9	7.01
	12	15.2	3.77	18.2	4.39	21.1	5.03	22.5	5.34	23.9	5.70	26.8	6.40	29.9	7.13
	14	15.2	3.83	18.2	4.44	21.1	5.09	22.5	5.45	23.9	5.79	26.8	6.51	29.9	7.27
	16	15.2	3.88	18.2	4.50	21.1	5.17	22.5	5.53	23.9	5.87	26.8	6.62	29.9	7.38
	18	15.2	3.94	18.2	4.58	21.1	5.25	22.5	5.62	23.9	5.98	26.8	6.73	29.9	7.52
	20	15.2	4.00	18.2	4.64	21.1	5.34	22.5	5.70	23.9	6.09	26.8	6.85	29.9	7.66
	21	15.2	4.02	18.2	4.69	21.1	5.39	22.5	5.76	23.9	6.15	26.8	6.93	29.9	7.74
	23	15.2	4.08	18.2	4.75	21.1	5.48	22.5	5.87	23.9	6.26	26.8	7.04	29.9	7.91
	25	15.2	4.14	18.2	4.83	21.1	5.59	22.5	5.98	23.9	6.46	26.8	7.41	29.9	8.44
	27	15.2	4.22	18.2	5.03	21.1	5.90	22.5	6.37	23.9	6.85	26.8	7.88	29.9	9.00
	29	15.2	4.44	18.2	5.31	21.1	6.26	22.5	6.76	23.9	7.29	26.8	8.38	29.9	9.59
	31	15.2	4.69	18.2	5.62	21.1	6.62	22.5	7.18	23.9	7.74	26.8	8.91	29.9	10.20
	33	15.2	4.97	18.2	5.95	21.1	7.04	22.5	7.60	23.9	8.22	26.8	9.47	29.9	10.84
35	15.2	5.25	18.2	6.29	21.1	7.43	22.5	8.05	23.9	8.69	26.8	10.06	29.9	11.51	
37	15.2	5.53	18.2	6.65	21.1	7.88	22.5	8.52	23.9	9.22	26.8	10.68	29.9	12.24	
39	15.2	5.84	18.2	7.01	21.1	8.33	22.5	9.03	23.9	9.78	26.8	11.32	29.9	12.99	
41	15.2	6.08	18.2	7.32	21.1	8.63	22.5	9.45	23.9	10.20	26.8	11.92	29.9	13.60	
43	15.2	6.48	18.2	7.82	21.1	8.93	22.5	9.87	23.9	10.47	26.8	12.53	29.9	14.20	
45	15.2	6.63	18.2	8.02	21.1	9.53	22.5	10.64	23.9	10.91	26.8	13.73	29.9	15.41	
48	15.2	6.76	18.2	8.21	21.1	10.06	22.5	11.35	23.9	11.43	26.8	14.81	29.9	16.58	

Abbreviations:

CR: Combination ratio

TC: Total capacity (kW)

PI: Power input (compressor + outdoor fan motor) (kW)

Notes:

Shaded cells indicate rating condition.

Table 2-8.6: 18HP cooling capacity

Combination (%) (Capacity index)	Outdoor temperature (°C DB)	Indoor temperature(°C DB/WB)													
		DB:20.8,WB:14		DB:23.3,WB:16		DB:25.8,WB:18		DB:27,WB:19		DB:28.2,WB:20		DB:30.7,WB:22		DB:32,WB:24	
		TC	PI	TC	PI	TC	PI	TC	PI	TC	PI	TC	PI	TC	PI
130%	-5	43.9	8.87	52.3	10.82	60.7	11.60	63.0	12.07	66.1	12.42	67.7	13.50	69.4	13.59
	-2	43.9	8.87	52.3	11.03	60.7	11.60	63.0	12.14	66.1	12.42	67.7	13.67	69.4	13.72
	0	43.9	9.02	52.3	11.22	60.7	12.03	63.0	12.81	66.1	13.14	67.7	13.84	69.4	13.91
	2	43.9	9.18	52.3	11.25	60.7	12.44	63.0	13.53	66.1	13.29	67.7	13.94	69.4	14.11
	4	43.9	9.39	52.3	11.47	60.7	12.87	63.0	13.59	66.1	13.46	67.7	14.15	69.4	14.38
	6	43.9	9.57	52.3	11.69	60.7	13.34	63.0	13.70	65.3	13.88	66.8	14.37	68.6	14.48
	8	43.9	9.80	52.3	11.96	60.7	14.01	63.0	14.37	64.5	14.33	66.1	14.42	67.7	14.63
	10	43.9	10.00	52.3	12.22	60.7	14.53	63.0	14.85	63.7	14.60	65.4	14.64	67.0	15.05
	12	43.9	10.17	52.3	12.45	60.7	14.82	62.1	15.07	63.0	14.82	64.5	14.86	66.1	15.14
	14	43.9	10.38	52.3	12.69	60.5	15.04	61.4	15.29	62.1	15.04	63.7	15.08	65.4	15.49
	16	43.9	10.55	52.3	12.95	59.8	15.26	60.5	15.49	61.2	15.48	62.9	15.30	64.5	15.73
	18	43.9	10.76	52.3	13.21	58.9	15.49	59.6	15.58	60.5	15.67	62.1	15.82	63.7	15.96
	20	43.9	10.99	52.3	14.06	58.0	16.26	58.9	16.34	59.6	16.43	61.2	16.58	62.9	16.75
	21	43.9	11.28	52.3	14.56	57.7	16.64	58.6	16.72	59.3	16.81	60.9	16.99	62.5	17.13
	23	43.9	12.10	52.3	15.61	57.0	17.40	57.7	17.48	58.4	17.57	60.0	17.74	61.6	17.92
	25	43.9	12.92	52.3	16.72	56.1	18.15	56.8	18.24	57.7	18.36	59.3	18.53	60.9	18.71
	27	43.9	13.80	52.3	17.89	55.4	18.92	56.1	19.03	56.8	19.12	58.4	19.32	60.0	19.53
	29	43.9	14.73	52.3	19.12	54.5	19.67	55.2	19.79	56.1	19.91	57.7	20.12	59.3	20.32
	31	43.9	15.73	52.1	20.23	53.6	20.46	54.5	20.58	55.2	20.67	56.8	20.90	58.4	21.14
	33	43.9	16.75	51.2	20.99	52.9	21.22	53.6	21.34	54.5	21.46	56.1	21.69	57.5	21.93
35	43.9	17.86	50.4	21.75	52.0	22.01	52.9	22.13	53.6	22.25	55.2	22.51	56.8	22.74	
37	43.9	19.00	49.6	22.54	51.2	22.80	52.0	22.92	52.9	23.07	54.3	23.33	55.9	23.59	
39	43.9	20.23	48.7	22.78	50.4	23.56	51.2	23.71	52.0	23.86	53.6	24.12	55.2	24.41	
41	43.9	21.29	48.2	23.00	49.8	23.78	50.7	23.93	51.4	24.08	53.0	24.17	53.1	24.63	
43	43.9	21.83	47.9	23.11	49.6	23.85	50.5	24.04	50.9	24.11	52.1	24.21	52.4	24.69	
45	43.9	22.92	47.6	23.33	49.0	24.07	49.9	24.20	50.2	24.22	50.7	24.30	51.4	25.15	
48	43.9	23.71	47.4	24.07	48.2	24.27	49.1	24.40	49.5	24.48	49.3	24.72	50.2	25.25	
120%	-5	40.5	8.56	48.2	10.37	56.1	12.27	60.0	13.38	62.9	13.94	64.3	14.39	65.7	14.77
	-2	40.5	8.65	48.2	10.48	56.1	12.39	60.0	13.45	62.9	14.11	64.3	14.51	65.7	14.82
	0	40.5	8.73	48.2	10.55	56.1	12.53	60.0	13.49	62.9	14.23	64.3	14.60	65.7	14.85
	2	40.5	8.75	48.2	10.66	56.1	12.62	60.0	13.62	62.9	14.29	64.3	14.70	65.7	14.88
	4	40.5	8.84	48.2	10.80	56.1	12.79	60.0	13.74	62.9	14.48	64.3	14.74	65.7	14.92
	6	40.5	8.93	48.2	10.88	56.1	12.95	60.0	13.89	62.9	14.64	64.3	14.86	65.7	14.97
	8	40.5	9.01	48.2	10.99	56.1	13.12	60.0	14.07	62.9	14.78	64.3	14.90	65.7	15.04
	10	40.5	9.12	48.2	11.14	56.1	13.24	60.0	14.32	62.9	14.80	64.3	14.95	65.7	15.11
	12	40.5	9.30	48.2	11.34	56.1	13.50	60.0	14.59	62.0	14.86	63.4	14.87	64.8	15.21
	14	40.5	9.47	48.2	11.58	56.1	13.77	60.0	14.88	61.1	14.95	62.7	15.09	64.1	15.39
	16	40.5	9.65	48.2	11.81	56.1	14.03	59.6	15.14	60.4	15.17	61.8	15.34	63.2	15.62
	18	40.5	9.82	48.2	12.04	56.1	14.50	58.8	15.49	59.5	15.55	60.9	15.70	62.5	15.84
	20	40.5	10.03	48.2	12.51	56.1	15.61	58.0	16.25	58.8	16.31	60.2	16.46	61.6	16.60
	21	40.5	10.11	48.2	12.95	56.1	16.17	57.5	16.63	58.2	16.69	59.8	16.84	61.3	17.01
	23	40.5	10.82	48.2	13.88	56.1	17.31	56.8	17.36	57.5	17.45	58.9	17.63	60.4	17.77
	25	40.5	11.55	48.2	14.85	55.2	18.07	55.9	18.13	56.6	18.21	58.2	18.39	59.6	18.56
	27	40.5	12.34	48.2	15.87	54.5	18.80	55.2	18.91	55.9	19.00	57.3	19.18	58.8	19.35
	29	40.5	13.16	48.2	16.96	53.6	19.56	54.3	19.67	55.0	19.76	56.4	19.97	58.0	20.14
	31	40.5	14.03	48.2	18.09	52.7	20.35	53.6	20.43	54.3	20.55	55.7	20.75	57.1	20.96
	33	40.5	14.94	48.2	19.30	52.0	21.11	52.7	21.22	53.4	21.31	54.8	21.55	56.2	21.75
35	40.5	15.90	48.2	20.58	51.1	21.86	51.8	21.98	52.7	22.10	54.1	22.34	55.5	22.57	
37	40.5	16.93	48.2	21.92	50.4	22.66	51.1	22.77	51.8	22.89	53.2	23.12	54.6	23.39	
39	40.5	18.01	48.0	23.15	49.5	23.42	50.2	23.56	50.9	23.68	52.5	23.94	53.9	24.18	
41	40.5	18.50	47.6	23.32	49.1	23.58	49.8	23.73	50.5	23.84	52.1	24.01	52.4	24.36	
43	40.5	18.78	47.4	23.48	48.7	23.72	49.4	23.82	50.1	23.93	51.2	24.07	51.6	24.85	
45	40.5	19.00	47.1	23.70	48.2	23.94	48.9	24.04	49.7	24.11	50.2	24.15	51.0	25.38	
48	40.5	19.13	46.7	23.96	47.6	24.16	48.1	24.18	49.1	24.34	49.4	24.40	50.4	25.70	

Abbreviations:

CR: Combination ratio

TC: Total capacity (kW)

PI: Power input (compressor + outdoor fan motor) (kW)

Notes:

Shaded cells indicate rating condition.

Table continued on next page ...

Table 2-8.6: 18HP cooling capacity (continued)

Combination (%) (Capacity index)	Outdoor temperature (°C DB)	Indoor temperature(°C DB/WB)													
		DB:20.8,WB:14		DB:23.3,WB:16		DB:25.8,WB:18		DB:27,WB:19		DB:28.2,WB:20		DB:30.7,WB:22		DB:32,WB:24	
		TC kW	PI kW	TC kW	PI kW	TC kW	PI kW	TC kW	PI kW	TC kW	PI kW	TC kW	PI kW	TC kW	PI kW
110%	-5	37.1	7.48	44.3	9.31	51.4	11.11	55.0	11.92	58.6	12.83	63.0	13.33	64.5	13.74
	-2	37.1	7.62	44.3	9.43	51.4	11.20	55.0	12.04	58.6	12.93	63.0	13.46	64.5	13.81
	0	37.1	7.70	44.3	9.48	51.4	11.29	55.0	12.12	58.6	13.07	63.0	13.59	64.5	13.98
	2	37.1	7.87	44.3	9.57	51.4	11.47	55.0	12.25	58.6	13.21	63.0	13.78	64.5	14.15
	4	37.1	8.02	44.3	9.68	51.4	11.57	55.0	12.40	58.6	13.42	63.0	13.98	64.5	14.28
	6	37.1	8.10	44.3	9.79	51.4	11.69	55.0	12.60	58.6	13.57	63.0	14.12	64.5	14.50
	8	37.1	8.18	44.3	9.95	51.4	11.82	55.0	12.73	58.6	13.72	63.0	14.22	64.5	14.65
	10	37.1	8.27	44.3	10.08	51.4	11.99	55.0	12.95	58.6	13.95	63.0	14.32	64.5	14.78
	12	37.1	8.45	44.3	10.29	51.4	12.22	55.0	13.21	58.6	14.21	62.3	14.53	63.6	14.97
	14	37.1	8.60	44.3	10.47	51.4	12.45	55.0	13.45	58.6	14.47	61.4	14.65	62.9	15.08
	16	37.1	8.74	44.3	10.67	51.4	12.69	55.0	13.71	58.6	14.76	60.7	14.82	62.0	15.24
	18	37.1	8.92	44.3	10.88	51.4	12.95	55.0	14.09	58.6	15.47	59.8	15.58	61.3	15.73
	20	37.1	9.09	44.3	11.11	51.4	13.71	55.0	15.14	57.7	16.23	59.1	16.34	60.4	16.49
	21	37.1	9.18	44.3	11.43	51.4	14.21	55.0	15.70	57.3	16.61	58.6	16.72	60.0	16.87
	23	37.1	9.62	44.3	12.25	51.4	15.23	55.0	16.84	56.4	17.34	57.9	17.51	59.1	17.66
	25	37.1	10.26	44.3	13.10	51.4	16.28	55.0	18.04	55.7	18.10	57.0	18.27	58.4	18.42
	27	37.1	10.93	44.3	14.00	51.4	17.42	54.1	18.80	54.8	18.86	56.3	19.03	57.5	19.21
	29	37.1	11.66	44.3	14.94	51.4	18.62	53.4	19.56	54.1	19.65	55.4	19.82	56.8	20.00
	31	37.1	12.42	44.3	15.93	51.4	19.88	52.5	20.32	53.2	20.41	54.6	20.58	55.9	20.79
	33	37.1	13.21	44.3	16.99	51.1	20.96	51.8	21.08	52.5	21.17	53.8	21.37	55.2	21.58
	35	37.1	14.06	44.3	18.10	50.2	21.72	50.9	21.84	51.6	21.96	52.9	22.16	54.3	22.36
	37	37.1	14.97	44.3	19.27	49.5	22.51	50.2	22.60	50.7	22.72	52.1	22.95	53.4	23.15
	39	37.1	15.90	44.3	20.52	48.6	23.27	49.3	23.39	50.0	23.50	51.3	23.74	52.7	23.97
	41	37.1	16.07	44.3	20.69	48.2	23.43	48.9	23.55	49.6	23.67	50.6	23.90	51.1	24.14
	43	37.1	16.23	44.3	20.95	47.8	23.60	48.5	23.72	49.2	23.83	50.1	23.99	50.3	24.63
	45	37.1	16.76	44.3	21.07	47.3	23.82	48.0	24.00	48.8	24.05	49.6	24.64	49.8	25.20
	48	37.1	17.31	44.3	22.81	46.6	23.93	47.3	24.12	48.2	24.26	48.8	24.68	49.2	25.42
	100%	-5	33.8	6.81	40.2	8.20	46.8	9.76	50.0	10.45	53.2	11.34	59.8	12.93	63.2
-2		33.8	6.89	40.2	8.31	46.8	9.87	50.0	10.65	53.2	11.50	59.8	13.08	63.2	13.58
0		33.8	6.96	40.2	8.39	46.8	9.98	50.0	10.78	53.2	11.60	59.8	13.30	63.2	13.73
2		33.8	7.10	40.2	8.51	46.8	10.09	50.0	10.92	53.2	11.73	59.8	13.49	63.2	13.95
4		33.8	7.15	40.2	8.59	46.8	10.24	50.0	11.08	53.2	11.89	59.8	13.62	63.2	14.10
6		33.8	7.26	40.2	8.76	46.8	10.37	50.0	11.28	53.2	12.06	59.8	13.82	63.2	14.32
8		33.8	7.40	40.2	8.89	46.8	10.56	50.0	11.41	53.2	12.26	59.8	14.03	63.2	14.55
10		33.8	7.48	40.2	9.06	46.8	10.73	50.0	11.60	53.2	12.48	59.8	14.27	63.2	14.76
12		33.8	7.60	40.2	9.24	46.8	10.93	50.0	11.81	53.2	12.72	59.8	14.53	62.3	14.88
14		33.8	7.75	40.2	9.41	46.8	11.14	50.0	12.04	53.2	12.95	59.8	14.82	61.6	15.06
16		33.8	7.89	40.2	9.59	46.8	11.37	50.0	12.28	53.2	13.21	59.5	15.00	60.7	15.23
18		33.8	8.04	40.2	9.76	46.8	11.58	50.0	12.51	53.2	13.48	58.8	15.49	60.0	15.61
20		33.8	8.19	40.2	9.97	46.8	11.93	50.0	13.15	53.2	14.44	57.9	16.22	59.1	16.37
21		33.8	8.27	40.2	10.06	46.8	12.37	50.0	13.62	53.2	14.94	57.5	16.60	58.8	16.75
23		33.8	8.48	40.2	10.73	46.8	13.24	50.0	14.59	53.2	16.02	56.8	17.36	57.9	17.51
25		33.8	9.03	40.2	11.46	46.8	14.18	50.0	15.64	53.2	17.16	55.9	18.12	57.1	18.27
27		33.8	9.65	40.2	12.22	46.8	15.14	50.0	16.72	53.2	18.36	55.0	18.88	56.3	19.06
29		33.8	10.26	40.2	13.04	46.8	16.17	50.0	17.86	53.0	19.50	54.3	19.67	55.5	19.82
31		33.8	10.93	40.2	13.91	46.8	17.25	50.0	19.06	52.3	20.26	53.4	20.43	54.6	20.61
33		33.8	11.60	40.2	14.82	46.8	18.39	50.0	20.35	51.4	21.02	52.7	21.19	53.9	21.40
35		33.8	12.34	40.2	15.76	46.8	19.62	50.0	21.69	50.5	21.78	51.8	21.98	53.0	22.16
37		33.8	13.13	40.2	16.78	46.8	20.90	49.1	22.45	49.8	22.57	51.1	22.77	52.1	22.95
39		33.8	13.94	40.2	17.83	46.8	22.25	48.4	23.21	48.9	23.33	50.2	23.53	51.4	23.77
41		33.8	14.59	40.2	18.48	46.8	23.06	47.6	23.37	48.6	23.69	49.3	24.09	50.7	24.25
43		33.8	15.24	40.2	19.13	46.8	23.49	46.9	23.65	48.2	23.92	49.6	24.24	49.8	24.53
45		33.8	16.11	40.2	20.00	46.8	23.89	45.9	23.97	48.0	24.35	49.2	24.62	48.8	24.85
48		33.8	16.82	40.2	20.70	46.8	23.93	44.0	24.24	47.9	24.78	46.2	24.87	47.7	25.08

Abbreviations:
 CR: Combination ratio
 TC: Total capacity (kW)
 PI: Power input (compressor + outdoor fan motor) (kW)

Notes:
 Shaded cells indicate rating condition.

Table continued on next page ...

Table 2-8.6: 18HP cooling capacity (continued)

Combination (%) (Capacity index)	Outdoor temperature (°C DB)	Indoor temperature(°C DB/WB)													
		DB:20.8,WB:14		DB:23.3,WB:16		DB:25.8,WB:18		DB:27,WB:19		DB:28.2,WB:20		DB:30.7,WB:22		DB:32,WB:24	
		TC kW	PI kW	TC kW	PI kW	TC kW	PI kW	TC kW	PI kW	TC kW	PI kW	TC kW	PI kW	TC kW	PI kW
90%	-5	30.4	6.02	36.3	7.23	42.1	8.53	45.0	9.30	47.9	9.90	53.7	11.38	59.6	13.03
	-2	30.4	6.08	36.3	7.30	42.1	8.64	45.0	9.43	47.9	10.02	53.7	11.49	59.6	13.16
	0	30.4	6.17	36.3	7.39	42.1	8.77	45.0	9.54	47.9	10.14	53.7	11.62	59.6	13.26
	2	30.4	6.26	36.3	7.49	42.1	8.86	45.0	9.69	47.9	10.30	53.7	11.86	59.6	13.45
	4	30.4	6.36	36.3	7.60	42.1	9.01	45.0	9.82	47.9	10.43	53.7	12.05	59.6	13.65
	6	30.4	6.45	36.3	7.75	42.1	9.17	45.0	10.01	47.9	10.62	53.7	12.23	59.6	13.88
	8	30.4	6.57	36.3	7.89	42.1	9.36	45.0	10.14	47.9	10.80	53.7	12.46	59.6	14.01
	10	30.4	6.69	36.3	8.07	42.1	9.53	45.0	10.29	47.9	11.05	53.7	12.62	59.6	14.23
	12	30.4	6.81	36.3	8.21	42.1	9.71	45.0	10.46	47.9	11.25	53.7	12.86	59.6	14.50
	14	30.4	6.93	36.3	8.36	42.1	9.88	45.0	10.67	47.9	11.46	53.7	13.10	59.6	14.76
	16	30.4	7.04	36.3	8.51	42.1	10.09	45.0	10.87	47.9	11.69	53.7	13.36	59.5	15.02
	18	30.4	7.16	36.3	8.68	42.1	10.26	45.0	11.08	47.9	11.93	53.7	13.62	58.8	15.49
	20	30.4	7.31	36.3	8.88	42.1	10.47	45.0	11.31	47.9	12.36	53.7	14.64	57.9	16.22
	21	30.4	7.37	36.3	8.94	42.1	10.64	45.0	11.69	47.9	12.80	53.7	15.17	57.5	16.60
	23	30.4	7.51	36.3	9.30	42.1	11.40	45.0	12.54	47.9	13.74	53.7	16.28	56.6	17.36
	25	30.4	7.92	36.3	9.94	42.1	12.19	45.0	13.42	47.9	14.67	53.7	17.42	55.9	18.12
	27	30.4	8.42	36.3	10.58	42.1	13.01	45.0	14.32	47.9	15.70	53.7	18.65	55.0	18.88
	29	30.4	8.97	36.3	11.28	42.1	13.88	45.0	15.29	47.9	16.78	53.2	19.50	54.3	19.64
	31	30.4	9.53	36.3	12.01	42.1	14.79	45.0	16.31	47.9	17.89	52.3	20.26	53.4	20.43
	33	30.4	10.11	36.3	12.77	42.1	15.78	45.0	17.39	47.9	19.09	51.6	21.05	52.7	21.19
35	30.4	10.76	36.3	13.59	42.1	16.81	45.0	18.53	47.9	20.35	50.7	21.81	51.8	21.98	
37	30.4	11.40	36.3	14.44	42.1	17.89	45.0	19.73	47.9	21.69	49.8	22.57	51.1	22.74	
39	30.4	12.10	36.3	15.38	42.1	19.03	45.0	21.02	47.9	23.09	49.1	23.36	50.2	23.53	
41	30.4	12.52	36.3	16.07	42.1	19.72	45.0	21.57	47.9	23.23	48.8	23.95	49.8	24.09	
43	30.4	13.12	36.3	16.77	42.1	20.42	45.0	22.13	47.9	23.73	48.5	24.26	49.4	24.46	
45	30.4	13.96	36.3	17.60	42.1	21.25	45.0	22.87	47.9	24.39	48.2	24.52	48.7	24.79	
48	30.4	14.73	36.3	18.41	42.1	22.05	45.0	23.16	47.9	24.59	47.8	24.86	47.3	25.12	
80%	-5	27.0	5.31	32.1	6.28	37.3	7.43	40.0	7.90	42.7	8.51	47.9	9.83	53.0	11.22
	-2	27.0	5.39	32.1	6.35	37.3	7.49	40.0	8.02	42.7	8.59	47.9	9.93	53.0	11.33
	0	27.0	5.48	32.1	6.43	37.3	7.59	40.0	8.12	42.7	8.74	47.9	10.07	53.0	11.49
	2	27.0	5.59	32.1	6.53	37.3	7.70	40.0	8.27	42.7	8.90	47.9	10.27	53.0	11.71
	4	27.0	5.68	32.1	6.63	37.3	7.84	40.0	8.46	42.7	9.05	47.9	10.46	53.0	11.86
	6	27.0	5.78	32.1	6.79	37.3	7.96	40.0	8.65	42.7	9.23	47.9	10.62	53.0	12.07
	8	27.0	5.89	32.1	6.95	37.3	8.15	40.0	8.79	42.7	9.43	47.9	10.77	53.0	12.30
	10	27.0	5.93	32.1	7.10	37.3	8.36	40.0	9.00	42.7	9.65	47.9	11.02	53.0	12.42
	12	27.0	6.02	32.1	7.22	37.3	8.51	40.0	9.18	42.7	9.85	47.9	11.23	53.0	12.66
	14	27.0	6.14	32.1	7.37	37.3	8.65	40.0	9.33	42.7	10.03	47.9	11.43	53.0	12.89
	16	27.0	6.23	32.1	7.48	37.3	8.83	40.0	9.50	42.7	10.20	47.9	11.66	53.0	13.13
	18	27.0	6.34	32.1	7.63	37.3	9.00	40.0	9.71	42.7	10.41	47.9	11.90	53.0	13.39
	20	27.0	6.46	32.1	7.78	37.3	9.18	40.0	9.88	42.7	10.61	47.9	12.34	53.0	14.32
	21	27.0	6.52	32.1	7.84	37.3	9.27	40.0	10.00	42.7	10.85	47.9	12.78	53.0	14.85
	23	27.0	6.64	32.1	8.01	37.3	9.71	40.0	10.64	42.7	11.61	47.9	13.68	53.0	15.93
	25	27.0	6.84	32.1	8.51	37.3	10.38	40.0	11.37	42.7	12.40	47.9	14.65	53.0	17.04
	27	27.0	7.28	32.1	9.06	37.3	11.05	40.0	12.13	42.7	13.24	47.9	15.64	53.0	18.24
	29	27.0	7.75	32.1	9.65	37.3	11.78	40.0	12.92	42.7	14.15	47.9	16.69	53.0	19.50
	31	27.0	8.21	32.1	10.26	37.3	12.54	40.0	13.77	42.7	15.08	47.9	17.83	52.1	20.26
	33	27.0	8.74	32.1	10.90	37.3	13.36	40.0	14.68	42.7	16.05	47.9	19.00	51.4	21.02
35	27.0	9.27	32.1	11.61	37.3	14.21	40.0	15.61	42.7	17.10	47.9	20.26	50.5	21.78	
37	27.0	9.82	32.1	12.31	37.3	15.11	40.0	16.63	42.7	18.21	47.9	21.60	49.8	22.54	
39	27.0	10.41	32.1	13.13	37.3	16.08	40.0	17.69	42.7	19.38	47.9	23.01	48.9	23.33	
41	27.0	10.64	32.1	13.24	37.3	16.31	40.0	18.16	42.7	19.73	47.9	23.59	48.6	23.74	
43	27.0	10.95	32.1	13.36	37.3	16.55	40.0	18.47	42.7	20.01	47.9	23.87	48.3	23.99	
45	27.0	11.27	32.1	13.52	37.3	16.87	40.0	18.86	42.7	20.35	47.9	24.13	47.7	24.39	
48	27.0	11.63	32.1	13.60	37.3	17.13	40.0	19.11	42.7	20.51	47.9	24.35	47.3	24.70	

Abbreviations:

CR: Combination ratio

TC: Total capacity (kW)

PI: Power input (compressor + outdoor fan motor) (kW)

Notes:

Shaded cells indicate rating condition.

Table continued on next page ...

Table 2-8.6: 18HP cooling capacity (continued)

Combination (%) (Capacity index)	Outdoor temperature (°C DB)	Indoor temperature(°C DB/WB)													
		DB:20.8,WB:14		DB:23.3,WB:16		DB:25.8,WB:18		DB:27,WB:19		DB:28.2,WB:20		DB:30.7,WB:22		DB:32,WB:24	
		TC kW	PI kW	TC kW	PI kW	TC kW	PI kW	TC kW	PI kW	TC kW	PI kW	TC kW	PI kW	TC kW	PI kW
70%	-5	23.6	4.74	28.2	5.56	32.7	6.30	35.0	6.75	37.3	7.20	41.8	8.24	46.4	9.48
	-2	23.6	4.78	28.2	5.58	32.7	6.33	35.0	6.88	37.3	7.33	41.8	8.37	46.4	9.61
	0	23.6	4.80	28.2	5.66	32.7	6.46	35.0	7.01	37.3	7.46	41.8	8.54	46.4	9.73
	2	23.6	4.83	28.2	5.69	32.7	6.57	35.0	7.14	37.3	7.59	41.8	8.72	46.4	9.89
	4	23.6	4.89	28.2	5.83	32.7	6.71	35.0	7.27	37.3	7.76	41.8	8.87	46.4	10.12
	6	23.6	4.97	28.2	5.93	32.7	6.88	35.0	7.50	37.3	7.94	41.8	9.02	46.4	10.32
	8	23.6	5.06	28.2	6.10	32.7	7.04	35.0	7.62	37.3	8.11	41.8	9.28	46.4	10.51
	10	23.6	5.17	28.2	6.20	32.7	7.22	35.0	7.78	37.3	8.33	41.8	9.47	46.4	10.64
	12	23.6	5.29	28.2	6.28	32.7	7.37	35.0	7.92	37.3	8.48	41.8	9.65	46.4	10.85
	14	23.6	5.38	28.2	6.40	32.7	7.48	35.0	8.04	37.3	8.62	41.8	9.82	46.4	11.05
	16	23.6	5.47	28.2	6.52	32.7	7.63	35.0	8.21	37.3	8.80	41.8	10.00	46.4	11.25
	18	23.6	5.55	28.2	6.64	32.7	7.78	35.0	8.36	37.3	8.95	41.8	10.20	46.4	11.49
	20	23.6	5.64	28.2	6.75	32.7	7.92	35.0	8.51	37.3	9.12	41.8	10.41	46.4	11.81
	21	23.6	5.70	28.2	6.81	32.7	7.98	35.0	8.60	37.3	9.21	41.8	10.55	46.4	12.22
	23	23.6	5.79	28.2	6.93	32.7	8.16	35.0	8.89	37.3	9.68	41.8	11.31	46.4	13.10
	25	23.6	5.91	28.2	7.22	32.7	8.68	35.0	9.50	37.3	10.32	41.8	12.10	46.4	14.00
	27	23.6	6.26	28.2	7.69	32.7	9.27	35.0	10.12	37.3	11.02	41.8	12.92	46.4	14.97
	29	23.6	6.64	28.2	8.16	32.7	9.85	35.0	10.79	37.3	11.72	41.8	13.77	46.4	15.99
	31	23.6	7.02	28.2	8.65	32.7	10.50	35.0	11.46	37.3	12.48	41.8	14.67	46.4	17.04
	33	23.6	7.45	28.2	9.21	32.7	11.17	35.0	12.19	37.3	13.30	41.8	15.64	46.4	18.18
35	23.6	7.89	28.2	9.76	32.7	11.84	35.0	12.98	37.3	14.15	41.8	16.66	46.4	19.38	
37	23.6	8.33	28.2	10.35	32.7	12.60	35.0	13.77	37.3	15.06	41.8	17.74	46.4	20.64	
39	23.6	8.83	28.2	10.96	32.7	13.36	35.0	14.65	37.3	15.99	41.8	18.86	46.4	21.98	
41	23.6	9.22	28.2	11.35	32.7	13.75	35.0	15.13	37.3	16.48	41.8	19.63	46.4	22.96	
43	23.6	9.97	28.2	12.13	32.7	14.32	35.0	15.94	37.3	16.96	41.8	20.35	46.4	23.67	
45	23.6	10.19	28.2	12.39	32.7	14.62	35.0	16.20	37.3	17.81	41.8	21.45	46.4	24.58	
48	23.6	10.38	28.2	12.46	32.7	14.80	35.0	16.48	37.3	18.30	41.8	22.46	46.4	25.18	
60%	-5	20.2	4.04	24.1	4.69	28.0	5.46	30.0	5.82	32.0	6.28	35.9	7.06	39.8	8.09
	-2	20.2	4.06	24.1	4.76	28.0	5.56	30.0	5.90	32.0	6.35	35.9	7.16	39.8	8.15
	0	20.2	4.13	24.1	4.82	28.0	5.64	30.0	5.98	32.0	6.45	35.9	7.27	39.8	8.25
	2	20.2	4.20	24.1	4.93	28.0	5.74	30.0	6.09	32.0	6.54	35.9	7.42	39.8	8.36
	4	20.2	4.32	24.1	5.03	28.0	5.85	30.0	6.17	32.0	6.64	35.9	7.53	39.8	8.48
	6	20.2	4.36	24.1	5.12	28.0	5.96	30.0	6.31	32.0	6.77	35.9	7.68	39.8	8.68
	8	20.2	4.44	24.1	5.21	28.0	6.07	30.0	6.42	32.0	6.91	35.9	7.83	39.8	8.81
	10	20.2	4.53	24.1	5.32	28.0	6.17	30.0	6.61	32.0	7.04	35.9	7.98	39.8	8.94
	12	20.2	4.62	24.1	5.41	28.0	6.28	30.0	6.72	32.0	7.16	35.9	8.13	39.8	9.09
	14	20.2	4.68	24.1	5.49	28.0	6.37	30.0	6.84	32.0	7.31	35.9	8.27	39.8	9.27
	16	20.2	4.73	24.1	5.58	28.0	6.49	30.0	6.96	32.0	7.42	35.9	8.42	39.8	9.44
	18	20.2	4.82	24.1	5.67	28.0	6.61	30.0	7.07	32.0	7.57	35.9	8.56	39.8	9.62
	20	20.2	4.88	24.1	5.79	28.0	6.72	30.0	7.22	32.0	7.72	35.9	8.74	39.8	9.82
	21	20.2	4.94	24.1	5.82	28.0	6.78	30.0	7.28	32.0	7.77	35.9	8.83	39.8	9.91
	23	20.2	5.00	24.1	5.93	28.0	6.90	30.0	7.42	32.0	7.92	35.9	9.18	39.8	10.55
	25	20.2	5.09	24.1	6.02	28.0	7.16	30.0	7.77	32.0	8.42	35.9	9.79	39.8	11.25
	27	20.2	5.29	24.1	6.40	28.0	7.63	30.0	8.30	32.0	8.97	35.9	10.43	39.8	12.01
	29	20.2	5.58	24.1	6.78	28.0	8.13	30.0	8.83	32.0	9.56	35.9	11.14	39.8	12.83
	31	20.2	5.93	24.1	7.19	28.0	8.62	30.0	9.38	32.0	10.17	35.9	11.84	39.8	13.65
	33	20.2	6.26	24.1	7.63	28.0	9.15	30.0	9.97	32.0	10.81	35.9	12.60	39.8	14.56
35	20.2	6.64	24.1	8.10	28.0	9.70	30.0	10.58	32.0	11.49	35.9	13.42	39.8	15.49	
37	20.2	7.02	24.1	8.56	28.0	10.29	30.0	11.22	32.0	12.19	35.9	14.26	39.8	16.48	
39	20.2	7.39	24.1	9.06	28.0	10.90	30.0	11.90	32.0	12.95	35.9	15.14	39.8	17.54	
41	20.2	7.63	24.1	9.45	28.0	11.30	30.0	12.37	32.0	13.42	35.9	15.85	39.8	18.33	
43	20.2	7.87	24.1	9.85	28.0	11.70	30.0	12.74	32.0	13.89	35.9	16.53	39.8	19.12	
45	20.2	8.24	24.1	10.35	28.0	12.17	30.0	13.22	32.0	14.58	35.9	17.27	39.8	20.18	
48	20.2	8.55	24.1	10.79	28.0	12.59	30.0	13.54	32.0	15.13	35.9	17.88	39.8	21.16	

Abbreviations:
 CR: Combination ratio
 TC: Total capacity (kW)
 PI: Power input (compressor + outdoor fan motor) (kW)

Notes:
 Shaded cells indicate rating condition.

Table continued on next page ...

Table 2-8.6: 18HP cooling capacity (continued)

Combination (%) (Capacity index)	Outdoor temperature (°C DB)	Indoor temperature(°C DB/WB)													
		DB:20.8,WB:14		DB:23.3,WB:16		DB:25.8,WB:18		DB:27,WB:19		DB:28.2,WB:20		DB:30.7,WB:22		DB:32,WB:24	
		TC	PI	TC	PI	TC	PI	TC	PI	TC	PI	TC	PI	TC	PI
50%	-5	16.9	3.51	20.2	4.06	23.4	4.66	25.0	4.88	26.6	5.15	29.8	5.86	33.2	6.31
	-2	16.9	3.54	20.2	4.14	23.4	4.71	25.0	4.95	26.6	5.24	29.8	5.94	33.2	6.40
	0	16.9	3.59	20.2	4.21	23.4	4.80	25.0	5.02	26.6	5.30	29.8	6.04	33.2	6.51
	2	16.9	3.65	20.2	4.26	23.4	4.88	25.0	5.09	26.6	5.40	29.8	6.06	33.2	6.63
	4	16.9	3.68	20.2	4.34	23.4	4.93	25.0	5.15	26.6	5.51	29.8	6.21	33.2	6.80
	6	16.9	3.75	20.2	4.40	23.4	5.01	25.0	5.27	26.6	5.61	29.8	6.31	33.2	7.00
	8	16.9	3.84	20.2	4.48	23.4	5.09	25.0	5.39	26.6	5.68	29.8	6.41	33.2	7.23
	10	16.9	3.92	20.2	4.53	23.4	5.17	25.0	5.47	26.6	5.85	29.8	6.58	33.2	7.34
	12	16.9	3.95	20.2	4.59	23.4	5.26	25.0	5.58	26.6	5.96	29.8	6.69	33.2	7.45
	14	16.9	4.00	20.2	4.65	23.4	5.32	25.0	5.70	26.6	6.05	29.8	6.81	33.2	7.60
	16	16.9	4.06	20.2	4.71	23.4	5.41	25.0	5.79	26.6	6.14	29.8	6.93	33.2	7.72
	18	16.9	4.12	20.2	4.79	23.4	5.50	25.0	5.88	26.6	6.26	29.8	7.04	33.2	7.86
	20	16.9	4.18	20.2	4.85	23.4	5.58	25.0	5.96	26.6	6.37	29.8	7.16	33.2	8.01
	21	16.9	4.21	20.2	4.91	23.4	5.64	25.0	6.02	26.6	6.43	29.8	7.25	33.2	8.10
	23	16.9	4.27	20.2	4.97	23.4	5.73	25.0	6.14	26.6	6.55	29.8	7.37	33.2	8.27
	25	16.9	4.33	20.2	5.06	23.4	5.85	25.0	6.26	26.6	6.75	29.8	7.75	33.2	8.83
	27	16.9	4.41	20.2	5.26	23.4	6.17	25.0	6.66	26.6	7.16	29.8	8.24	33.2	9.41
	29	16.9	4.65	20.2	5.55	23.4	6.55	25.0	7.07	26.6	7.63	29.8	8.77	33.2	10.03
	31	16.9	4.91	20.2	5.88	23.4	6.93	25.0	7.51	26.6	8.10	29.8	9.32	33.2	10.67
	33	16.9	5.20	20.2	6.23	23.4	7.37	25.0	7.95	26.6	8.59	29.8	9.91	33.2	11.34
35	16.9	5.50	20.2	6.58	23.4	7.78	25.0	8.42	26.6	9.09	29.8	10.52	33.2	12.04	
37	16.9	5.79	20.2	6.96	23.4	8.24	25.0	8.91	26.6	9.65	29.8	11.17	33.2	12.80	
39	16.9	6.11	20.2	7.34	23.4	8.71	25.0	9.44	26.6	10.23	29.8	11.84	33.2	13.59	
41	16.9	6.36	20.2	7.65	23.4	9.03	25.0	9.88	26.6	10.67	29.8	12.47	33.2	14.22	
43	16.9	6.78	20.2	8.18	23.4	9.34	25.0	10.32	26.6	10.95	29.8	13.10	33.2	14.85	
45	16.9	6.94	20.2	8.39	23.4	9.97	25.0	11.12	26.6	11.41	29.8	14.36	33.2	16.12	
48	16.9	7.07	20.2	8.59	23.4	10.52	25.0	11.87	26.6	11.95	29.8	15.49	33.2	17.34	

Abbreviations:

CR: Combination ratio

TC: Total capacity (kW)

PI: Power input (compressor + outdoor fan motor) (kW)

Notes:

Shaded cells indicate rating condition.

Table 2-8.7: 20HP cooling capacity

Combination (%) (Capacity index)	Outdoor temperature (°C DB)	Indoor temperature(°C DB/WB)													
		DB:20.8,WB:14		DB:23.3,WB:16		DB:25.8,WB:18		DB:27,WB:19		DB:28.2,WB:20		DB:30.7,WB:22		DB:32,WB:24	
		TC kW	PI kW	TC kW	PI kW	TC kW	PI kW	TC kW	PI kW	TC kW	PI kW	TC kW	PI kW	TC kW	PI kW
130%	-5	49.2	12.11	58.6	14.78	68.0	15.85	70.6	16.49	74.0	16.96	75.8	18.44	77.7	18.56
	-2	49.2	12.11	58.6	15.07	68.0	15.85	70.6	16.59	74.0	16.96	75.8	18.68	77.7	18.74
	0	49.2	12.32	58.6	15.33	68.0	16.43	70.6	17.50	74.0	17.95	75.8	18.90	77.7	18.99
	2	49.2	12.54	58.6	15.36	68.0	16.99	70.6	18.48	74.0	18.15	75.8	19.04	77.7	19.28
	4	49.2	12.82	58.6	15.66	68.0	17.58	70.6	18.56	74.0	18.39	75.8	19.33	77.7	19.64
	6	49.2	13.07	58.6	15.97	68.0	18.23	70.6	18.72	73.2	18.96	74.9	19.63	76.9	19.79
	8	49.2	13.38	58.6	16.34	68.0	19.14	70.6	19.63	72.3	19.58	74.1	19.69	75.9	19.98
	10	49.2	13.66	58.6	16.69	68.0	19.85	70.6	20.29	71.4	19.94	73.2	19.99	75.0	20.56
	12	49.2	13.90	58.6	17.01	68.0	20.25	69.6	20.59	70.6	20.24	72.2	20.30	74.0	20.69
	14	49.2	14.18	58.6	17.33	67.8	20.55	68.8	20.89	69.6	20.55	71.4	20.60	73.2	21.16
	16	49.2	14.42	58.6	17.69	67.0	20.85	67.8	21.16	68.6	21.15	70.4	20.90	72.2	21.49
	18	49.2	14.70	58.6	18.05	66.0	21.16	66.8	21.29	67.8	21.41	69.6	21.61	71.4	21.81
	20	49.2	15.02	58.6	19.21	65.0	22.20	66.0	22.32	66.8	22.44	68.6	22.64	70.4	22.88
	21	49.2	15.41	58.6	19.89	64.6	22.72	65.6	22.84	66.4	22.96	68.2	23.20	70.0	23.40
	23	49.2	16.53	58.6	21.33	63.8	23.76	64.6	23.88	65.4	24.00	67.2	24.24	69.0	24.48
	25	49.2	17.65	58.6	22.84	62.8	24.80	63.6	24.92	64.6	25.08	66.4	25.32	68.2	25.56
	27	49.2	18.85	58.6	24.44	62.0	25.84	62.8	26.00	63.6	26.12	65.4	26.40	67.2	26.68
	29	49.2	20.13	58.6	26.12	61.0	26.88	61.8	27.04	62.8	27.20	64.6	27.48	66.4	27.76
	31	49.2	21.49	58.4	27.63	60.0	27.95	61.0	28.11	61.8	28.23	63.6	28.55	65.4	28.87
	33	49.2	22.88	57.4	28.67	59.2	28.99	60.0	29.15	61.0	29.31	62.8	29.63	64.4	29.95
35	49.2	24.40	56.4	29.71	58.2	30.07	59.2	30.23	60.0	30.39	61.8	30.75	63.6	31.07	
37	49.2	25.96	55.6	30.79	57.4	31.15	58.2	31.31	59.2	31.51	60.8	31.87	62.6	32.23	
39	49.2	27.63	54.6	31.11	56.4	32.19	57.4	32.39	58.2	32.59	60.0	32.95	61.8	33.34	
41	49.2	29.09	54.0	31.41	55.8	32.49	56.8	32.69	57.6	32.89	59.4	33.01	59.4	33.65	
43	49.2	29.82	53.6	31.56	55.5	32.58	56.5	32.84	57.0	32.93	58.3	33.07	58.7	33.72	
45	49.2	31.31	53.3	31.87	54.9	32.88	55.9	33.05	56.2	33.08	56.7	33.19	57.6	34.36	
48	49.2	32.39	53.1	32.88	54.0	33.16	55.0	33.32	55.5	33.44	55.2	33.77	56.2	34.48	
120%	-5	45.4	11.70	54.0	14.17	62.8	16.76	67.2	18.27	70.4	19.05	72.0	19.66	73.6	20.18
	-2	45.4	11.81	54.0	14.32	62.8	16.92	67.2	18.38	70.4	19.27	72.0	19.82	73.6	20.25
	0	45.4	11.92	54.0	14.41	62.8	17.12	67.2	18.42	70.4	19.44	72.0	19.94	73.6	20.29
	2	45.4	11.95	54.0	14.56	62.8	17.24	67.2	18.60	70.4	19.52	72.0	20.09	73.6	20.33
	4	45.4	12.07	54.0	14.75	62.8	17.48	67.2	18.77	70.4	19.78	72.0	20.13	73.6	20.39
	6	45.4	12.20	54.0	14.86	62.8	17.69	67.2	18.98	70.4	19.99	72.0	20.29	73.6	20.45
	8	45.4	12.31	54.0	15.01	62.8	17.93	67.2	19.22	70.4	20.19	72.0	20.36	73.6	20.55
	10	45.4	12.46	54.0	15.21	62.8	18.09	67.2	19.57	70.4	20.21	72.0	20.42	73.6	20.64
	12	45.4	12.70	54.0	15.50	62.8	18.45	67.2	19.93	69.4	20.29	71.0	20.31	72.6	20.77
	14	45.4	12.94	54.0	15.81	62.8	18.81	67.2	20.33	68.4	20.42	70.2	20.62	71.8	21.02
	16	45.4	13.18	54.0	16.13	62.8	19.17	66.8	20.68	67.6	20.72	69.2	20.96	70.8	21.34
	18	45.4	13.42	54.0	16.45	62.8	19.81	65.8	21.16	66.6	21.24	68.2	21.44	70.0	21.64
	20	45.4	13.70	54.0	17.09	62.8	21.32	65.0	22.20	65.8	22.28	67.4	22.48	69.0	22.68
	21	45.4	13.82	54.0	17.69	62.8	22.08	64.4	22.72	65.2	22.80	67.0	23.00	68.6	23.24
	23	45.4	14.77	54.0	18.97	62.8	23.64	63.6	23.72	64.4	23.84	66.0	24.08	67.6	24.28
	25	45.4	15.77	54.0	20.29	61.8	24.68	62.6	24.76	63.4	24.88	65.2	25.12	66.8	25.36
	27	45.4	16.85	54.0	21.68	61.0	25.68	61.8	25.84	62.6	25.96	64.2	26.19	65.8	26.44
	29	45.4	17.97	54.0	23.16	60.0	26.71	60.8	26.87	61.6	26.99	63.2	27.27	65.0	27.51
	31	45.4	19.17	54.0	24.72	59.0	27.79	60.0	27.91	60.8	28.07	62.4	28.35	64.0	28.63
	33	45.4	20.41	54.0	26.36	58.2	28.83	59.0	28.99	59.8	29.11	61.4	29.43	63.0	29.71
35	45.4	21.72	54.0	28.11	57.2	29.86	58.0	30.03	59.0	30.19	60.6	30.51	62.2	30.83	
37	45.4	23.12	54.0	29.95	56.4	30.95	57.2	31.11	58.0	31.27	59.6	31.59	61.2	31.95	
39	45.4	24.60	53.8	31.63	55.4	31.99	56.2	32.19	57.0	32.35	58.8	32.71	60.4	33.02	
41	45.4	25.27	53.4	31.85	55.0	32.21	55.8	32.41	56.6	32.57	58.4	32.80	58.7	33.27	
43	45.4	25.65	53.1	32.08	54.5	32.41	55.3	32.53	56.1	32.69	57.3	32.89	57.8	33.94	
45	45.4	25.95	52.8	32.38	54.0	32.71	54.8	32.84	55.6	32.94	56.2	32.99	57.2	34.68	
48	45.4	26.13	52.3	32.73	53.3	33.00	53.9	33.03	55.0	33.24	55.3	33.33	56.4	35.10	

Abbreviations:

CR: Combination ratio

TC: Total capacity (kW)

PI: Power input (compressor + outdoor fan motor) (kW)

Notes:

Shaded cells indicate rating condition.

Table continued on next page ...

Table 2-8.7: 20HP cooling capacity (continued)

Combination (%) (Capacity index)	Outdoor temperature (°C DB)	Indoor temperature(°C DB/WB)													
		DB:20.8,WB:14		DB:23.3,WB:16		DB:25.8,WB:18		DB:27,WB:19		DB:28.2,WB:20		DB:30.7,WB:22		DB:32,WB:24	
		TC	PI	TC	PI	TC	PI	TC	PI	TC	PI	TC	PI	TC	PI
110%	-5	41.6	10.21	49.6	12.72	57.6	15.18	61.6	16.29	65.6	17.53	70.6	18.20	72.2	18.76
	-2	41.6	10.41	49.6	12.88	57.6	15.30	61.6	16.45	65.6	17.66	70.6	18.38	72.2	18.87
	0	41.6	10.52	49.6	12.96	57.6	15.42	61.6	16.56	65.6	17.86	70.6	18.56	72.2	19.09
	2	41.6	10.75	49.6	13.08	57.6	15.66	61.6	16.74	65.6	18.05	70.6	18.83	72.2	19.33
	4	41.6	10.96	49.6	13.23	57.6	15.81	61.6	16.94	65.6	18.33	70.6	19.09	72.2	19.51
	6	41.6	11.07	49.6	13.38	57.6	15.96	61.6	17.21	65.6	18.53	70.6	19.29	72.2	19.81
	8	41.6	11.17	49.6	13.59	57.6	16.14	61.6	17.39	65.6	18.74	70.6	19.42	72.2	20.02
	10	41.6	11.30	49.6	13.78	57.6	16.37	61.6	17.69	65.6	19.05	70.6	19.56	72.2	20.19
	12	41.6	11.54	49.6	14.06	57.6	16.69	61.6	18.05	65.6	19.41	69.8	19.85	71.2	20.45
	14	41.6	11.74	49.6	14.30	57.6	17.01	61.6	18.37	65.6	19.77	68.8	20.01	70.4	20.60
	16	41.6	11.94	49.6	14.58	57.6	17.33	61.6	18.73	65.6	20.17	68.0	20.25	69.4	20.82
	18	41.6	12.18	49.6	14.86	57.6	17.69	61.6	19.25	65.6	21.13	67.0	21.28	68.6	21.48
	20	41.6	12.42	49.6	15.18	57.6	18.73	61.6	20.68	64.6	22.16	66.2	22.32	67.6	22.52
	21	41.6	12.54	49.6	15.61	57.6	19.41	61.6	21.45	64.2	22.68	65.6	22.84	67.2	23.04
	23	41.6	13.14	49.6	16.73	57.6	20.81	61.6	23.00	63.2	23.68	64.8	23.92	66.2	24.12
	25	41.6	14.02	49.6	17.89	57.6	22.24	61.6	24.64	62.4	24.72	63.8	24.96	65.4	25.16
	27	41.6	14.94	49.6	19.13	57.6	23.80	60.6	25.68	61.4	25.76	63.0	26.00	64.4	26.24
	29	41.6	15.93	49.6	20.41	57.6	25.44	59.8	26.72	60.6	26.84	62.0	27.07	63.6	27.32
	31	41.6	16.97	49.6	21.76	57.6	27.16	58.8	27.75	59.6	27.87	61.2	28.11	62.6	28.39
	33	41.6	18.05	49.6	23.20	57.2	28.63	58.0	28.79	58.8	28.91	60.2	29.19	61.8	29.47
35	41.6	19.21	49.6	24.72	56.2	29.67	57.0	29.83	57.8	29.99	59.2	30.27	60.8	30.55	
37	41.6	20.45	49.6	26.32	55.4	30.75	56.2	30.87	56.8	31.03	58.4	31.35	59.8	31.63	
39	41.6	21.72	49.6	28.04	54.4	31.79	55.2	31.95	56.0	32.11	57.4	32.43	59.0	32.75	
41	41.6	21.95	49.6	28.26	54.0	32.01	54.8	32.17	55.6	32.33	56.7	32.65	57.2	32.97	
43	41.6	22.17	49.6	28.62	53.5	32.24	54.3	32.40	55.1	32.55	56.2	32.77	56.3	33.64	
45	41.6	22.89	49.6	28.78	53.0	32.53	53.8	32.79	54.7	32.85	55.6	33.66	55.8	34.42	
48	41.6	23.64	49.6	31.16	52.2	32.68	52.9	32.95	54.0	33.14	54.7	33.72	55.1	34.72	
100%	-5	37.8	9.30	45.0	11.20	52.4	13.33	56.0	14.28	59.6	15.50	67.0	17.66	70.8	18.43
	-2	37.8	9.42	45.0	11.35	52.4	13.48	56.0	14.55	59.6	15.70	67.0	17.87	70.8	18.55
	0	37.8	9.51	45.0	11.47	52.4	13.63	56.0	14.73	59.6	15.85	67.0	18.16	70.8	18.76
	2	37.8	9.70	45.0	11.62	52.4	13.78	56.0	14.92	59.6	16.03	67.0	18.43	70.8	19.05
	4	37.8	9.77	45.0	11.73	52.4	13.99	56.0	15.14	59.6	16.24	67.0	18.61	70.8	19.26
	6	37.8	9.91	45.0	11.97	52.4	14.16	56.0	15.41	59.6	16.47	67.0	18.87	70.8	19.56
	8	37.8	10.10	45.0	12.15	52.4	14.42	56.0	15.59	59.6	16.74	67.0	19.17	70.8	19.88
	10	37.8	10.22	45.0	12.38	52.4	14.65	56.0	15.85	59.6	17.05	67.0	19.49	70.8	20.17
	12	37.8	10.38	45.0	12.62	52.4	14.93	56.0	16.13	59.6	17.37	67.0	19.85	69.8	20.32
	14	37.8	10.58	45.0	12.86	52.4	15.21	56.0	16.45	59.6	17.69	67.0	20.24	69.0	20.57
	16	37.8	10.78	45.0	13.10	52.4	15.53	56.0	16.77	59.6	18.05	66.6	20.49	68.0	20.81
	18	37.8	10.98	45.0	13.34	52.4	15.81	56.0	17.09	59.6	18.41	65.8	21.16	67.2	21.32
	20	37.8	11.18	45.0	13.62	52.4	16.29	56.0	17.97	59.6	19.73	64.8	22.16	66.2	22.36
	21	37.8	11.30	45.0	13.74	52.4	16.89	56.0	18.61	59.6	20.41	64.4	22.68	65.8	22.88
	23	37.8	11.58	45.0	14.65	52.4	18.09	56.0	19.93	59.6	21.88	63.6	23.72	64.8	23.92
	25	37.8	12.34	45.0	15.65	52.4	19.37	56.0	21.36	59.6	23.44	62.6	24.76	64.0	24.96
	27	37.8	13.18	45.0	16.69	52.4	20.68	56.0	22.84	59.6	25.08	61.6	25.80	63.0	26.04
	29	37.8	14.01	45.0	17.81	52.4	22.08	56.0	24.40	59.4	26.63	60.8	26.87	62.2	27.07
	31	37.8	14.93	45.0	19.01	52.4	23.56	56.0	26.04	58.6	27.67	59.8	27.91	61.2	28.15
	33	37.8	15.85	45.0	20.25	52.4	25.12	56.0	27.79	57.6	28.71	59.0	28.95	60.4	29.23
35	37.8	16.85	45.0	21.52	52.4	26.79	56.0	29.63	56.6	29.75	58.0	30.03	59.4	30.27	
37	37.8	17.93	45.0	22.92	52.4	28.55	55.0	30.67	55.8	30.83	57.2	31.10	58.4	31.35	
39	37.8	19.05	45.0	24.36	52.4	30.39	54.2	31.71	54.8	31.87	56.2	32.15	57.6	32.47	
41	37.8	19.93	45.0	25.25	52.4	31.50	53.4	31.93	54.4	32.36	55.2	32.90	56.8	33.13	
43	37.8	20.82	45.0	26.14	52.4	32.08	52.5	32.30	54.0	32.67	55.6	33.12	55.8	33.50	
45	37.8	22.01	45.0	27.32	52.4	32.63	51.4	32.74	53.7	33.26	55.1	33.63	54.6	33.95	
48	37.8	22.98	45.0	28.28	52.4	32.68	49.3	33.12	53.6	33.85	51.7	33.98	53.4	34.26	

Abbreviations:

CR: Combination ratio

TC: Total capacity (kW)

PI: Power input (compressor + outdoor fan motor) (kW)

Notes:

Shaded cells indicate rating condition.

Table continued on next page ...

Table 2-8.7: 20HP cooling capacity (continued)

Combination (%) (Capacity index)	Outdoor temperature (°C DB)	Indoor temperature(°C DB/WB)													
		DB:20.8,WB:14		DB:23.3,WB:16		DB:25.8,WB:18		DB:27,WB:19		DB:28.2,WB:20		DB:30.7,WB:22		DB:32,WB:24	
		TC kW	PI kW	TC kW	PI kW	TC kW	PI kW	TC kW	PI kW	TC kW	PI kW	TC kW	PI kW	TC kW	PI kW
90%	-5	34.0	8.23	40.6	9.87	47.2	11.65	50.4	12.71	53.6	13.52	60.2	15.54	66.8	17.80
	-2	34.0	8.30	40.6	9.97	47.2	11.80	50.4	12.89	53.6	13.68	60.2	15.70	66.8	17.97
	0	34.0	8.43	40.6	10.10	47.2	11.97	50.4	13.04	53.6	13.86	60.2	15.87	66.8	18.11
	2	34.0	8.56	40.6	10.23	47.2	12.10	50.4	13.24	53.6	14.08	60.2	16.20	66.8	18.38
	4	34.0	8.69	40.6	10.38	47.2	12.30	50.4	13.42	53.6	14.25	60.2	16.46	66.8	18.65
	6	34.0	8.80	40.6	10.58	47.2	12.53	50.4	13.67	53.6	14.50	60.2	16.71	66.8	18.96
	8	34.0	8.97	40.6	10.78	47.2	12.79	50.4	13.85	53.6	14.76	60.2	17.02	66.8	19.14
	10	34.0	9.14	40.6	11.02	47.2	13.02	50.4	14.06	53.6	15.09	60.2	17.24	66.8	19.44
	12	34.0	9.30	40.6	11.22	47.2	13.26	50.4	14.29	53.6	15.37	60.2	17.57	66.8	19.80
	14	34.0	9.46	40.6	11.42	47.2	13.50	50.4	14.57	53.6	15.65	60.2	17.89	66.8	20.16
	16	34.0	9.62	40.6	11.62	47.2	13.78	50.4	14.86	53.6	15.97	60.2	18.25	66.6	20.52
	18	34.0	9.78	40.6	11.86	47.2	14.01	50.4	15.13	53.6	16.29	60.2	18.61	65.8	21.16
	20	34.0	9.98	40.6	12.13	47.2	14.30	50.4	15.45	53.6	16.89	60.2	20.00	64.8	22.16
	21	34.0	10.06	40.6	12.22	47.2	14.53	50.4	15.97	53.6	17.49	60.2	20.72	64.4	22.68
	23	34.0	10.26	40.6	12.70	47.2	15.57	50.4	17.13	53.6	18.77	60.2	22.24	63.4	23.72
	25	34.0	10.82	40.6	13.58	47.2	16.65	50.4	18.33	53.6	20.04	60.2	23.80	62.6	24.76
	27	34.0	11.50	40.6	14.46	47.2	17.77	50.4	19.57	53.6	21.44	60.2	25.48	61.6	25.79
	29	34.0	12.26	40.6	15.41	47.2	18.97	50.4	20.88	53.6	22.92	59.6	26.63	60.8	26.83
	31	34.0	13.02	40.6	16.41	47.2	20.20	50.4	22.28	53.6	24.44	58.6	27.67	59.8	27.91
	33	34.0	13.81	40.6	17.45	47.2	21.56	50.4	23.76	53.6	26.08	57.8	28.75	59.0	28.95
35	34.0	14.69	40.6	18.57	47.2	22.96	50.4	25.32	53.6	27.79	56.8	29.79	58.0	30.03	
37	34.0	15.57	40.6	19.73	47.2	24.44	50.4	26.95	53.6	29.63	55.8	30.83	57.2	31.06	
39	34.0	16.53	40.6	21.00	47.2	25.99	50.4	28.71	53.6	31.55	55.0	31.91	56.2	32.14	
41	34.0	17.10	40.6	21.95	47.2	26.94	50.4	29.47	53.6	31.74	54.6	32.72	55.8	32.90	
43	34.0	17.92	40.6	22.90	47.2	27.89	50.4	30.23	53.6	32.41	54.3	33.14	55.3	33.41	
45	34.0	19.06	40.6	24.04	47.2	29.03	50.4	31.24	53.6	33.31	54.0	33.49	54.5	33.86	
48	34.0	20.12	40.6	25.15	47.2	30.13	50.4	31.64	53.6	33.60	53.6	33.96	53.0	34.32	
80%	-5	30.2	7.25	36.0	8.57	41.8	10.15	44.8	10.79	47.8	11.62	53.6	13.43	59.4	15.33
	-2	30.2	7.36	36.0	8.68	41.8	10.24	44.8	10.96	47.8	11.73	53.6	13.56	59.4	15.48
	0	30.2	7.48	36.0	8.79	41.8	10.36	44.8	11.09	47.8	11.94	53.6	13.75	59.4	15.69
	2	30.2	7.63	36.0	8.91	41.8	10.51	44.8	11.30	47.8	12.15	53.6	14.03	59.4	15.99
	4	30.2	7.76	36.0	9.06	41.8	10.71	44.8	11.56	47.8	12.37	53.6	14.29	59.4	16.21
	6	30.2	7.89	36.0	9.28	41.8	10.88	44.8	11.81	47.8	12.60	53.6	14.50	59.4	16.48
	8	30.2	8.04	36.0	9.49	41.8	11.13	44.8	12.01	47.8	12.88	53.6	14.71	59.4	16.80
	10	30.2	8.11	36.0	9.70	41.8	11.42	44.8	12.30	47.8	13.18	53.6	15.06	59.4	16.97
	12	30.2	8.23	36.0	9.86	41.8	11.62	44.8	12.54	47.8	13.46	53.6	15.33	59.4	17.29
	14	30.2	8.39	36.0	10.06	41.8	11.82	44.8	12.74	47.8	13.70	53.6	15.61	59.4	17.61
	16	30.2	8.51	36.0	10.22	41.8	12.06	44.8	12.98	47.8	13.94	53.6	15.93	59.4	17.93
	18	30.2	8.67	36.0	10.42	41.8	12.30	44.8	13.26	47.8	14.22	53.6	16.25	59.4	18.29
	20	30.2	8.83	36.0	10.62	41.8	12.54	44.8	13.50	47.8	14.50	53.6	16.85	59.4	19.57
	21	30.2	8.91	36.0	10.70	41.8	12.66	44.8	13.66	47.8	14.82	53.6	17.45	59.4	20.29
	23	30.2	9.07	36.0	10.94	41.8	13.26	44.8	14.53	47.8	15.85	53.6	18.69	59.4	21.76
	25	30.2	9.34	36.0	11.62	41.8	14.18	44.8	15.53	47.8	16.93	53.6	20.01	59.4	23.28
	27	30.2	9.94	36.0	12.38	41.8	15.10	44.8	16.57	47.8	18.09	53.6	21.36	59.4	24.92
	29	30.2	10.58	36.0	13.18	41.8	16.09	44.8	17.65	47.8	19.33	53.6	22.80	59.4	26.64
	31	30.2	11.22	36.0	14.02	41.8	17.13	44.8	18.81	47.8	20.61	53.6	24.36	58.4	27.67
	33	30.2	11.94	36.0	14.90	41.8	18.25	44.8	20.05	47.8	21.92	53.6	25.96	57.6	28.71
35	30.2	12.66	36.0	15.85	41.8	19.41	44.8	21.32	47.8	23.36	53.6	27.67	56.6	29.75	
37	30.2	13.42	36.0	16.81	41.8	20.65	44.8	22.72	47.8	24.88	53.6	29.51	55.8	30.79	
39	30.2	14.22	36.0	17.93	41.8	21.96	44.8	24.16	47.8	26.48	53.6	31.43	54.8	31.87	
41	30.2	14.54	36.0	18.09	41.8	22.28	44.8	24.80	47.8	26.96	53.6	32.23	54.5	32.43	
43	30.2	14.96	36.0	18.25	41.8	22.60	44.8	25.23	47.8	27.33	53.6	32.60	54.1	32.77	
45	30.2	15.39	36.0	18.46	41.8	23.04	44.8	25.76	47.8	27.80	53.6	32.96	53.5	33.31	
48	30.2	15.89	36.0	18.57	41.8	23.39	44.8	26.10	47.8	28.02	53.6	33.27	53.0	33.74	

Abbreviations:

CR: Combination ratio

TC: Total capacity (kW)

PI: Power input (compressor + outdoor fan motor) (kW)

Notes:

Shaded cells indicate rating condition.

Table continued on next page ...

Table 2-8.7: 20HP cooling capacity (continued)

Combination (%) (Capacity index)	Outdoor temperature (°C DB)	Indoor temperature(°C DB/WB)													
		DB:20.8,WB:14		DB:23.3,WB:16		DB:25.8,WB:18		DB:27,WB:19		DB:28.2,WB:20		DB:30.7,WB:22		DB:32,WB:24	
		TC kW	PI kW	TC kW	PI kW	TC kW	PI kW	TC kW	PI kW	TC kW	PI kW	TC kW	PI kW	TC kW	PI kW
70%	-5	26.4	6.47	31.6	7.59	36.6	8.60	39.2	9.22	41.8	9.84	46.8	11.26	52.0	12.94
	-2	26.4	6.52	31.6	7.62	36.6	8.65	39.2	9.40	41.8	10.02	46.8	11.44	52.0	13.12
	0	26.4	6.56	31.6	7.73	36.6	8.83	39.2	9.57	41.8	10.19	46.8	11.67	52.0	13.30
	2	26.4	6.60	31.6	7.77	36.6	8.97	39.2	9.75	41.8	10.37	46.8	11.91	52.0	13.51
	4	26.4	6.68	31.6	7.96	36.6	9.17	39.2	9.93	41.8	10.60	46.8	12.11	52.0	13.83
	6	26.4	6.79	31.6	8.10	36.6	9.40	39.2	10.25	41.8	10.85	46.8	12.32	52.0	14.10
	8	26.4	6.91	31.6	8.33	36.6	9.61	39.2	10.41	41.8	11.08	46.8	12.68	52.0	14.36
	10	26.4	7.06	31.6	8.47	36.6	9.86	39.2	10.62	41.8	11.38	46.8	12.94	52.0	14.54
	12	26.4	7.23	31.6	8.59	36.6	10.06	39.2	10.82	41.8	11.58	46.8	13.18	52.0	14.82
	14	26.4	7.35	31.6	8.74	36.6	10.22	39.2	10.98	41.8	11.78	46.8	13.42	52.0	15.10
	16	26.4	7.47	31.6	8.91	36.6	10.42	39.2	11.22	41.8	12.02	46.8	13.66	52.0	15.37
	18	26.4	7.59	31.6	9.07	36.6	10.62	39.2	11.42	41.8	12.22	46.8	13.94	52.0	15.69
	20	26.4	7.71	31.6	9.23	36.6	10.82	39.2	11.62	41.8	12.46	46.8	14.22	52.0	16.13
	21	26.4	7.79	31.6	9.30	36.6	10.90	39.2	11.74	41.8	12.58	46.8	14.42	52.0	16.69
	23	26.4	7.91	31.6	9.46	36.6	11.14	39.2	12.14	41.8	13.22	46.8	15.45	52.0	17.89
	25	26.4	8.07	31.6	9.86	36.6	11.86	39.2	12.98	41.8	14.10	46.8	16.53	52.0	19.13
	27	26.4	8.55	31.6	10.50	36.6	12.66	39.2	13.82	41.8	15.05	46.8	17.65	52.0	20.45
	29	26.4	9.07	31.6	11.14	36.6	13.46	39.2	14.74	41.8	16.01	46.8	18.81	52.0	21.84
	31	26.4	9.58	31.6	11.82	36.6	14.34	39.2	15.65	41.8	17.05	46.8	20.05	52.0	23.28
	33	26.4	10.18	31.6	12.58	36.6	15.26	39.2	16.65	41.8	18.17	46.8	21.37	52.0	24.84
35	26.4	10.78	31.6	13.34	36.6	16.17	39.2	17.73	41.8	19.33	46.8	22.76	52.0	26.47	
37	26.4	11.38	31.6	14.14	36.6	17.21	39.2	18.81	41.8	20.57	46.8	24.24	52.0	28.19	
39	26.4	12.06	31.6	14.98	36.6	18.25	39.2	20.01	41.8	21.84	46.8	25.76	52.0	30.03	
41	26.4	12.59	31.6	15.51	36.6	18.78	39.2	20.67	41.8	22.51	46.8	26.82	52.0	31.36	
43	26.4	13.62	31.6	16.57	36.6	19.56	39.2	21.78	41.8	23.17	46.8	27.80	52.0	32.33	
45	26.4	13.92	31.6	16.93	36.6	19.97	39.2	22.13	41.8	24.33	46.8	29.30	52.0	33.58	
48	26.4	14.18	31.6	17.02	36.6	20.21	39.2	22.52	41.8	25.00	46.8	30.67	52.0	34.40	
60%	-5	22.6	5.52	27.0	6.40	31.4	7.46	33.6	7.95	35.8	8.59	40.2	9.64	44.6	11.06
	-2	22.6	5.55	27.0	6.50	31.4	7.60	33.6	8.06	35.8	8.67	40.2	9.78	44.6	11.13
	0	22.6	5.64	27.0	6.58	31.4	7.70	33.6	8.17	35.8	8.82	40.2	9.93	44.6	11.27
	2	22.6	5.74	27.0	6.74	31.4	7.84	33.6	8.33	35.8	8.94	40.2	10.13	44.6	11.42
	4	22.6	5.90	27.0	6.87	31.4	7.99	33.6	8.43	35.8	9.07	40.2	10.29	44.6	11.58
	6	22.6	5.95	27.0	7.00	31.4	8.15	33.6	8.61	35.8	9.25	40.2	10.50	44.6	11.85
	8	22.6	6.07	27.0	7.11	31.4	8.30	33.6	8.77	35.8	9.44	40.2	10.70	44.6	12.04
	10	22.6	6.19	27.0	7.27	31.4	8.42	33.6	9.02	35.8	9.62	40.2	10.90	44.6	12.22
	12	22.6	6.31	27.0	7.39	31.4	8.58	33.6	9.18	35.8	9.78	40.2	11.10	44.6	12.42
	14	22.6	6.39	27.0	7.51	31.4	8.70	33.6	9.34	35.8	9.98	40.2	11.30	44.6	12.66
	16	22.6	6.47	27.0	7.63	31.4	8.86	33.6	9.50	35.8	10.14	40.2	11.50	44.6	12.90
	18	22.6	6.59	27.0	7.75	31.4	9.02	33.6	9.66	35.8	10.34	40.2	11.70	44.6	13.14
	20	22.6	6.67	27.0	7.91	31.4	9.18	33.6	9.86	35.8	10.54	40.2	11.94	44.6	13.42
	21	22.6	6.75	27.0	7.94	31.4	9.26	33.6	9.94	35.8	10.62	40.2	12.06	44.6	13.54
	23	22.6	6.83	27.0	8.11	31.4	9.42	33.6	10.14	35.8	10.82	40.2	12.54	44.6	14.41
	25	22.6	6.95	27.0	8.23	31.4	9.78	33.6	10.62	35.8	11.50	40.2	13.38	44.6	15.37
	27	22.6	7.23	27.0	8.74	31.4	10.42	33.6	11.34	35.8	12.26	40.2	14.25	44.6	16.41
	29	22.6	7.63	27.0	9.26	31.4	11.10	33.6	12.06	35.8	13.06	40.2	15.21	44.6	17.53
	31	22.6	8.11	27.0	9.82	31.4	11.78	33.6	12.82	35.8	13.89	40.2	16.17	44.6	18.64
	33	22.6	8.54	27.0	10.42	31.4	12.50	33.6	13.62	35.8	14.77	40.2	17.21	44.6	19.88
35	22.6	9.06	27.0	11.06	31.4	13.26	33.6	14.45	35.8	15.69	40.2	18.33	44.6	21.16	
37	22.6	9.58	27.0	11.70	31.4	14.05	33.6	15.33	35.8	16.65	40.2	19.48	44.6	22.52	
39	22.6	10.10	27.0	12.38	31.4	14.89	33.6	16.25	35.8	17.69	40.2	20.68	44.6	23.96	
41	22.6	10.43	27.0	12.91	31.4	15.43	33.6	16.90	35.8	18.34	40.2	21.66	44.6	25.04	
43	22.6	10.75	27.0	13.46	31.4	15.98	33.6	17.41	35.8	18.98	40.2	22.58	44.6	26.12	
45	22.6	11.26	27.0	14.14	31.4	16.63	33.6	18.06	35.8	19.92	40.2	23.59	44.6	27.57	
48	22.6	11.68	27.0	14.74	31.4	17.20	33.6	18.50	35.8	20.67	40.2	24.43	44.6	28.91	

Abbreviations:

CR: Combination ratio

TC: Total capacity (kW)

PI: Power input (compressor + outdoor fan motor) (kW)

Notes:

Shaded cells indicate rating condition.

Table continued on next page ...

Table 2-8.7: 20HP cooling capacity (continued)

Combination (%) (Capacity index)	Outdoor temperature (°C DB)	Indoor temperature(°C DB/WB)													
		DB:20.8,WB:14		DB:23.3,WB:16		DB:25.8,WB:18		DB:27,WB:19		DB:28.2,WB:20		DB:30.7,WB:22		DB:32,WB:24	
		TC kW	PI kW	TC kW	PI kW	TC kW	PI kW	TC kW	PI kW	TC kW	PI kW	TC kW	PI kW	TC kW	PI kW
50%	-5	18.9	4.80	22.6	5.54	26.2	6.37	28.0	6.67	29.8	7.04	33.4	8.00	37.2	8.62
	-2	18.9	4.83	22.6	5.66	26.2	6.44	28.0	6.76	29.8	7.16	33.4	8.11	37.2	8.74
	0	18.9	4.91	22.6	5.75	26.2	6.55	28.0	6.85	29.8	7.24	33.4	8.24	37.2	8.89
	2	18.9	4.98	22.6	5.82	26.2	6.67	28.0	6.96	29.8	7.37	33.4	8.28	37.2	9.06
	4	18.9	5.03	22.6	5.92	26.2	6.74	28.0	7.04	29.8	7.52	33.4	8.49	37.2	9.29
	6	18.9	5.12	22.6	6.01	26.2	6.84	28.0	7.20	29.8	7.66	33.4	8.62	37.2	9.57
	8	18.9	5.24	22.6	6.12	26.2	6.96	28.0	7.36	29.8	7.76	33.4	8.75	37.2	9.87
	10	18.9	5.35	22.6	6.19	26.2	7.07	28.0	7.47	29.8	7.99	33.4	8.98	37.2	10.02
	12	18.9	5.39	22.6	6.27	26.2	7.19	28.0	7.63	29.8	8.14	33.4	9.14	37.2	10.18
	14	18.9	5.47	22.6	6.35	26.2	7.27	28.0	7.79	29.8	8.27	33.4	9.30	37.2	10.38
	16	18.9	5.55	22.6	6.43	26.2	7.39	28.0	7.91	29.8	8.39	33.4	9.46	37.2	10.54
	18	18.9	5.63	22.6	6.55	26.2	7.51	28.0	8.03	29.8	8.55	33.4	9.62	37.2	10.74
	20	18.9	5.71	22.6	6.63	26.2	7.63	28.0	8.14	29.8	8.70	33.4	9.78	37.2	10.94
	21	18.9	5.75	22.6	6.71	26.2	7.71	28.0	8.23	29.8	8.78	33.4	9.90	37.2	11.06
	23	18.9	5.83	22.6	6.79	26.2	7.83	28.0	8.39	29.8	8.94	33.4	10.06	37.2	11.30
	25	18.9	5.91	22.6	6.91	26.2	7.99	28.0	8.55	29.8	9.22	33.4	10.58	37.2	12.06
	27	18.9	6.03	22.6	7.19	26.2	8.42	28.0	9.10	29.8	9.78	33.4	11.26	37.2	12.86
	29	18.9	6.35	22.6	7.59	26.2	8.94	28.0	9.66	29.8	10.42	33.4	11.98	37.2	13.70
	31	18.9	6.71	22.6	8.03	26.2	9.46	28.0	10.26	29.8	11.06	33.4	12.74	37.2	14.57
	33	18.9	7.11	22.6	8.50	26.2	10.06	28.0	10.86	29.8	11.74	33.4	13.54	37.2	15.49
35	18.9	7.51	22.6	8.98	26.2	10.62	28.0	11.50	29.8	12.42	33.4	14.37	37.2	16.45	
37	18.9	7.91	22.6	9.50	26.2	11.26	28.0	12.18	29.8	13.18	33.4	15.25	37.2	17.49	
39	18.9	8.35	22.6	10.02	26.2	11.90	28.0	12.90	29.8	13.98	33.4	16.17	37.2	18.57	
41	18.9	8.69	22.6	10.45	26.2	12.33	28.0	13.50	29.8	14.58	33.4	17.03	37.2	19.43	
43	18.9	9.26	22.6	11.17	26.2	12.76	28.0	14.10	29.8	14.95	33.4	17.90	37.2	20.29	
45	18.9	9.48	22.6	11.46	26.2	13.62	28.0	15.20	29.8	15.58	33.4	19.62	37.2	22.02	
48	18.9	9.66	22.6	11.73	26.2	14.37	28.0	16.21	29.8	16.33	33.4	21.16	37.2	23.69	

Abbreviations:

CR: Combination ratio

TC: Total capacity (kW)

PI: Power input (compressor + outdoor fan motor) (kW)

Notes:

Shaded cells indicate rating condition.

Table 2-8.8: 22HP cooling capacity

Combination (%) (Capacity index)	Outdoor temperature (°C DB)	Indoor temperature(°C DB/WB)													
		DB:20.8,WB:14		DB:23.3,WB:16		DB:25.8,WB:18		DB:27,WB:19		DB:28.2,WB:20		DB:30.7,WB:22		DB:32,WB:24	
		TC	PI	TC	PI	TC	PI	TC	PI	TC	PI	TC	PI	TC	PI
130%	-5	51.8	14.14	61.7	17.25	71.6	18.50	74.4	19.25	78.0	19.80	79.9	21.52	81.9	21.66
	-2	51.8	14.14	61.7	17.59	71.6	18.50	74.4	19.36	78.0	19.80	79.9	21.80	81.9	21.88
	0	51.8	14.38	61.7	17.89	71.6	19.17	74.4	20.42	78.0	20.95	79.9	22.06	81.9	22.17
	2	51.8	14.64	61.7	17.93	71.6	19.83	74.4	21.57	78.0	21.19	79.9	22.23	81.9	22.50
	4	51.8	14.96	61.7	18.28	71.6	20.52	74.4	21.67	78.0	21.46	79.9	22.57	81.9	22.93
	6	51.8	15.25	61.7	18.65	71.6	21.27	74.4	21.85	77.1	22.13	78.9	22.91	81.0	23.09
	8	51.8	15.62	61.7	19.07	71.6	22.34	74.4	22.91	76.1	22.85	78.0	22.99	79.9	23.32
	10	51.8	15.94	61.7	19.48	71.6	23.17	74.4	23.68	75.2	23.27	77.1	23.34	79.0	23.99
	12	51.8	16.22	61.7	19.86	71.6	23.63	73.3	24.03	74.4	23.63	76.1	23.69	78.0	24.15
	14	51.8	16.55	61.7	20.23	71.4	23.98	72.5	24.39	73.3	23.98	75.2	24.04	77.1	24.69
	16	51.8	16.83	61.7	20.65	70.6	24.34	71.4	24.70	72.3	24.69	74.2	24.40	76.1	25.08
	18	51.8	17.15	61.7	21.07	69.5	24.70	70.4	24.84	71.4	24.99	73.3	25.22	75.2	25.45
	20	51.8	17.53	61.7	22.42	68.5	25.92	69.5	26.06	70.4	26.20	72.3	26.43	74.2	26.71
	21	51.8	17.99	61.7	23.21	68.1	26.52	69.1	26.66	70.0	26.80	71.8	27.08	73.7	27.31
	23	51.8	19.30	61.7	24.89	67.2	27.73	68.1	27.87	68.9	28.01	70.8	28.29	72.7	28.57
	25	51.8	20.60	61.7	26.66	66.2	28.95	67.0	29.09	68.1	29.27	70.0	29.55	71.8	29.83
	27	51.8	22.00	61.7	28.53	65.3	30.16	66.2	30.34	67.0	30.48	68.9	30.81	70.8	31.14
	29	51.8	23.49	61.7	30.48	64.3	31.37	65.1	31.56	66.2	31.74	68.1	32.07	70.0	32.40
	31	51.8	25.08	61.5	32.25	63.2	32.63	64.3	32.81	65.1	32.95	67.0	33.33	68.9	33.70
	33	51.8	26.71	60.5	33.47	62.4	33.84	63.2	34.03	64.3	34.21	66.2	34.59	67.8	34.96
35	51.8	28.48	59.4	34.68	61.3	35.10	62.4	35.29	63.2	35.47	65.1	35.89	67.0	36.26	
37	51.8	30.30	58.6	35.94	60.5	36.36	61.3	36.55	62.4	36.78	64.1	37.20	65.9	37.62	
39	51.8	32.25	57.5	36.31	59.4	37.57	60.5	37.80	61.3	38.03	63.2	38.45	65.1	38.92	
41	51.8	33.95	56.9	36.67	58.8	37.92	59.8	38.15	60.7	38.39	62.6	38.53	62.6	39.27	
43	51.8	34.81	56.5	36.84	58.5	38.03	59.5	38.33	60.1	38.44	61.4	38.60	61.9	39.36	
45	51.8	36.54	56.2	37.19	57.9	38.38	58.9	38.58	59.2	38.62	59.8	38.74	60.7	40.10	
48	51.8	37.80	56.0	38.38	56.9	38.70	58.0	38.90	58.4	39.03	58.2	39.41	59.3	40.25	
120%	-5	47.8	13.66	56.9	16.54	66.2	19.56	70.8	21.33	74.2	22.23	75.9	22.94	77.5	23.55
	-2	47.8	13.79	56.9	16.71	66.2	19.75	70.8	21.45	74.2	22.50	75.9	23.13	77.5	23.63
	0	47.8	13.92	56.9	16.82	66.2	19.98	70.8	21.50	74.2	22.70	75.9	23.27	77.5	23.68
	2	47.8	13.95	56.9	17.00	66.2	20.12	70.8	21.71	74.2	22.78	75.9	23.45	77.5	23.73
	4	47.8	14.09	56.9	17.22	66.2	20.40	70.8	21.91	74.2	23.09	75.9	23.49	77.5	23.80
	6	47.8	14.24	56.9	17.35	66.2	20.64	70.8	22.15	74.2	23.34	75.9	23.69	77.5	23.87
	8	47.8	14.37	56.9	17.53	66.2	20.93	70.8	22.43	74.2	23.57	75.9	23.76	77.5	23.99
	10	47.8	14.54	56.9	17.76	66.2	21.11	70.8	22.84	74.2	23.59	75.9	23.83	77.5	24.09
	12	47.8	14.82	56.9	18.09	66.2	21.53	70.8	23.26	73.1	23.69	74.8	23.70	76.5	24.24
	14	47.8	15.10	56.9	18.46	66.2	21.95	70.8	23.73	72.1	23.83	74.0	24.06	75.6	24.54
	16	47.8	15.38	56.9	18.83	66.2	22.37	70.4	24.14	71.2	24.19	72.9	24.47	74.6	24.91
	18	47.8	15.66	56.9	19.20	66.2	23.12	69.3	24.70	70.2	24.79	71.9	25.03	73.7	25.26
	20	47.8	15.99	56.9	19.95	66.2	24.89	68.5	25.92	69.3	26.01	71.0	26.24	72.7	26.47
	21	47.8	16.13	56.9	20.65	66.2	25.78	67.8	26.52	68.7	26.61	70.6	26.85	72.3	27.13
	23	47.8	17.25	56.9	22.14	66.2	27.59	67.0	27.69	67.8	27.83	69.5	28.11	71.2	28.34
	25	47.8	18.41	56.9	23.68	65.1	28.80	66.0	28.90	66.8	29.04	68.7	29.32	70.4	29.60
	27	47.8	19.67	56.9	25.31	64.3	29.97	65.1	30.16	66.0	30.30	67.6	30.57	69.3	30.86
	29	47.8	20.97	56.9	27.03	63.2	31.18	64.1	31.37	64.9	31.51	66.6	31.83	68.5	32.11
	31	47.8	22.37	56.9	28.85	62.2	32.44	63.2	32.58	64.1	32.77	65.7	33.09	67.4	33.42
	33	47.8	23.82	56.9	30.76	61.3	33.65	62.2	33.84	63.0	33.98	64.7	34.35	66.4	34.68
35	47.8	25.36	56.9	32.81	60.3	34.86	61.1	35.05	62.2	35.24	63.8	35.61	65.5	35.98	
37	47.8	26.99	56.9	34.96	59.4	36.12	60.3	36.31	61.1	36.49	62.8	36.87	64.5	37.29	
39	47.8	28.71	56.7	36.92	58.4	37.34	59.2	37.57	60.1	37.75	61.9	38.17	63.6	38.55	
41	47.8	29.50	56.2	37.18	57.9	37.60	58.8	37.83	59.6	38.02	61.5	38.28	61.8	38.83	
43	47.8	29.94	55.9	37.44	57.5	37.83	58.3	37.97	59.1	38.16	60.4	38.38	60.8	39.61	
45	47.8	30.29	55.6	37.79	56.9	38.18	57.7	38.33	58.6	38.45	59.2	38.50	60.2	40.47	
48	47.8	30.49	55.1	38.21	56.2	38.51	56.8	38.56	58.0	38.80	58.3	38.91	59.4	40.97	

Abbreviations:

CR: Combination ratio

TC: Total capacity (kW)

PI: Power input (compressor + outdoor fan motor) (kW)

Notes:

Shaded cells indicate rating condition.

Table continued on next page ...

Table 2-8.8: 22HP cooling capacity (continued)

Combination (%) (Capacity index)	Outdoor temperature (°C DB)	Indoor temperature(°C DB/WB)													
		DB:20.8,WB:14		DB:23.3,WB:16		DB:25.8,WB:18		DB:27,WB:19		DB:28.2,WB:20		DB:30.7,WB:22		DB:32,WB:24	
		TC	PI	TC	PI	TC	PI	TC	PI	TC	PI	TC	PI	TC	PI
110%	-5	43.8	11.92	52.3	14.84	60.7	17.71	64.9	19.01	69.1	20.46	74.4	21.25	76.1	21.90
	-2	43.8	12.15	52.3	15.03	60.7	17.86	64.9	19.20	69.1	20.62	74.4	21.46	76.1	22.02
	0	43.8	12.27	52.3	15.12	60.7	18.00	64.9	19.32	69.1	20.85	74.4	21.67	76.1	22.28
	2	43.8	12.54	52.3	15.26	60.7	18.28	64.9	19.53	69.1	21.07	74.4	21.98	76.1	22.56
	4	43.8	12.79	52.3	15.44	60.7	18.45	64.9	19.78	69.1	21.39	74.4	22.28	76.1	22.77
	6	43.8	12.92	52.3	15.62	60.7	18.63	64.9	20.09	69.1	21.63	74.4	22.52	76.1	23.12
	8	43.8	13.04	52.3	15.86	60.7	18.84	64.9	20.30	69.1	21.88	74.4	22.67	76.1	23.36
	10	43.8	13.19	52.3	16.08	60.7	19.11	64.9	20.65	69.1	22.24	74.4	22.83	76.1	23.57
	12	43.8	13.47	52.3	16.41	60.7	19.48	64.9	21.07	69.1	22.65	73.5	23.17	75.0	23.87
	14	43.8	13.70	52.3	16.69	60.7	19.86	64.9	21.44	69.1	23.07	72.5	23.35	74.2	24.04
	16	43.8	13.94	52.3	17.01	60.7	20.23	64.9	21.86	69.1	23.54	71.6	23.63	73.1	24.30
	18	43.8	14.22	52.3	17.34	60.7	20.65	64.9	22.47	69.1	24.66	70.6	24.84	72.3	25.08
	20	43.8	14.50	52.3	17.71	60.7	21.86	64.9	24.14	68.1	25.87	69.7	26.06	71.2	26.29
	21	43.8	14.63	52.3	18.22	60.7	22.65	64.9	25.03	67.6	26.48	69.1	26.66	70.8	26.89
	23	43.8	15.33	52.3	19.53	60.7	24.29	64.9	26.85	66.6	27.64	68.3	27.91	69.7	28.15
	25	43.8	16.36	52.3	20.88	60.7	25.96	64.9	28.76	65.7	28.85	67.2	29.13	68.9	29.37
	27	43.8	17.43	52.3	22.33	60.7	27.78	63.9	29.97	64.7	30.07	66.4	30.34	67.9	30.62
	29	43.8	18.60	52.3	23.82	60.7	29.69	63.0	31.18	63.9	31.32	65.3	31.60	67.0	31.88
	31	43.8	19.81	52.3	25.40	60.7	31.70	62.0	32.40	62.8	32.53	64.5	32.81	66.0	33.14
	33	43.8	21.07	52.3	27.08	60.3	33.42	61.1	33.61	62.0	33.75	63.4	34.07	65.1	34.40
35	43.8	22.42	52.3	28.85	59.2	34.63	60.1	34.82	60.9	35.01	62.4	35.33	64.1	35.66	
37	43.8	23.87	52.3	30.72	58.4	35.89	59.2	36.03	59.8	36.22	61.5	36.59	63.0	36.92	
39	43.8	25.36	52.3	32.72	57.3	37.10	58.2	37.29	59.0	37.48	60.5	37.85	62.2	38.22	
41	43.8	25.62	52.3	32.98	56.9	37.36	57.7	37.55	58.6	37.74	59.7	38.11	60.3	38.48	
43	43.8	25.88	52.3	33.41	56.4	37.63	57.3	37.81	58.1	38.00	59.2	38.25	59.4	39.27	
45	43.8	26.72	52.3	33.59	55.8	37.97	56.7	38.27	57.6	38.35	58.6	39.29	58.8	40.18	
48	43.8	27.59	52.3	36.37	55.0	38.15	55.8	38.45	56.9	38.68	57.6	39.36	58.1	40.52	
100%	-5	39.8	10.86	47.4	13.07	55.2	15.56	59.0	16.67	62.8	18.09	70.6	20.61	74.6	21.51
	-2	39.8	10.99	47.4	13.25	55.2	15.74	59.0	16.98	62.8	18.33	70.6	20.85	74.6	21.65
	0	39.8	11.10	47.4	13.38	55.2	15.91	59.0	17.19	62.8	18.50	70.6	21.20	74.6	21.89
	2	39.8	11.32	47.4	13.57	55.2	16.08	59.0	17.41	62.8	18.71	70.6	21.51	74.6	22.24
	4	39.8	11.41	47.4	13.70	55.2	16.32	59.0	17.67	62.8	18.95	70.6	21.72	74.6	22.48
	6	39.8	11.57	47.4	13.97	55.2	16.53	59.0	17.98	62.8	19.23	70.6	22.03	74.6	22.83
	8	39.8	11.79	47.4	14.18	55.2	16.84	59.0	18.19	62.8	19.54	70.6	22.38	74.6	23.21
	10	39.8	11.93	47.4	14.45	55.2	17.11	59.0	18.50	62.8	19.90	70.6	22.75	74.6	23.54
	12	39.8	12.12	47.4	14.73	55.2	17.43	59.0	18.83	62.8	20.28	70.6	23.16	73.5	23.72
	14	39.8	12.35	47.4	15.01	55.2	17.76	59.0	19.20	62.8	20.65	70.6	23.63	72.7	24.01
	16	39.8	12.59	47.4	15.29	55.2	18.13	59.0	19.57	62.8	21.07	70.2	23.91	71.6	24.28
	18	39.8	12.82	47.4	15.57	55.2	18.46	59.0	19.95	62.8	21.49	69.3	24.70	70.8	24.89
	20	39.8	13.05	47.4	15.89	55.2	19.02	59.0	20.97	62.8	23.03	68.3	25.87	69.7	26.10
	21	39.8	13.19	47.4	16.03	55.2	19.72	59.0	21.72	62.8	23.82	67.9	26.47	69.3	26.71
	23	39.8	13.52	47.4	17.11	55.2	21.11	59.0	23.26	62.8	25.54	67.0	27.68	68.3	27.92
	25	39.8	14.40	47.4	18.27	55.2	22.60	59.0	24.94	62.8	27.36	66.0	28.90	67.4	29.13
	27	39.8	15.38	47.4	19.48	55.2	24.14	59.0	26.66	62.8	29.27	64.9	30.11	66.4	30.39
	29	39.8	16.36	47.4	20.79	55.2	25.78	59.0	28.48	62.6	31.09	64.1	31.37	65.5	31.60
	31	39.8	17.43	47.4	22.19	55.2	27.50	59.0	30.39	61.7	32.30	63.0	32.58	64.5	32.86
	33	39.8	18.50	47.4	23.63	55.2	29.32	59.0	32.44	60.7	33.51	62.2	33.79	63.6	34.12
35	39.8	19.67	47.4	25.12	55.2	31.27	59.0	34.58	59.6	34.72	61.1	35.05	62.6	35.33	
37	39.8	20.93	47.4	26.75	55.2	33.33	57.9	35.79	58.8	35.98	60.3	36.30	61.5	36.59	
39	39.8	22.23	47.4	28.43	55.2	35.47	57.1	37.01	57.7	37.20	59.2	37.52	60.7	37.89	
41	39.8	23.27	47.4	29.47	55.2	36.77	56.2	37.27	57.3	37.77	58.2	38.40	59.8	38.67	
43	39.8	24.31	47.4	30.51	55.2	37.45	55.3	37.70	56.9	38.13	58.5	38.65	58.7	39.10	
45	39.8	25.69	47.4	31.89	55.2	38.09	54.2	38.22	56.6	38.82	58.0	39.25	57.6	39.62	
48	39.8	26.82	47.4	33.01	55.2	38.15	51.9	38.65	56.5	39.51	54.5	39.66	56.3	39.99	

Abbreviations:
 CR: Combination ratio
 TC: Total capacity (kW)
 PI: Power input (compressor + outdoor fan motor) (kW)

Notes:
 Shaded cells indicate rating condition.

Table continued on next page ...

Table 2-8.8: 22HP cooling capacity (continued)

Combination (%) (Capacity index)	Outdoor temperature (°C DB)	Indoor temperature(°C DB/WB)													
		DB:20.8,WB:14		DB:23.3,WB:16		DB:25.8,WB:18		DB:27,WB:19		DB:28.2,WB:20		DB:30.7,WB:22		DB:32,WB:24	
		TC	PI	TC	PI	TC	PI	TC	PI	TC	PI	TC	PI	TC	PI
90%	-5	35.8	9.60	42.8	11.52	49.7	13.59	53.1	14.83	56.5	15.78	63.4	18.14	70.4	20.78
	-2	35.8	9.69	42.8	11.64	49.7	13.77	53.1	15.04	56.5	15.97	63.4	18.32	70.4	20.98
	0	35.8	9.84	42.8	11.79	49.7	13.98	53.1	15.22	56.5	16.17	63.4	18.53	70.4	21.14
	2	35.8	9.99	42.8	11.94	49.7	14.12	53.1	15.45	56.5	16.43	63.4	18.91	70.4	21.45
	4	35.8	10.14	42.8	12.11	49.7	14.36	53.1	15.66	56.5	16.64	63.4	19.21	70.4	21.77
	6	35.8	10.28	42.8	12.35	49.7	14.63	53.1	15.96	56.5	16.93	63.4	19.50	70.4	22.13
	8	35.8	10.47	42.8	12.59	49.7	14.92	53.1	16.16	56.5	17.22	63.4	19.87	70.4	22.34
	10	35.8	10.67	42.8	12.86	49.7	15.19	53.1	16.41	56.5	17.62	63.4	20.12	70.4	22.70
	12	35.8	10.86	42.8	13.10	49.7	15.47	53.1	16.68	56.5	17.94	63.4	20.51	70.4	23.12
	14	35.8	11.05	42.8	13.33	49.7	15.75	53.1	17.01	56.5	18.27	63.4	20.88	70.4	23.54
	16	35.8	11.23	42.8	13.56	49.7	16.08	53.1	17.34	56.5	18.64	63.4	21.30	70.2	23.95
	18	35.8	11.42	42.8	13.84	49.7	16.36	53.1	17.66	56.5	19.01	63.4	21.72	69.3	24.70
	20	35.8	11.65	42.8	14.16	49.7	16.69	53.1	18.04	56.5	19.71	63.4	23.35	68.3	25.87
	21	35.8	11.75	42.8	14.26	49.7	16.96	53.1	18.64	56.5	20.42	63.4	24.19	67.9	26.47
	23	35.8	11.98	42.8	14.82	49.7	18.18	53.1	20.00	56.5	21.90	63.4	25.96	66.8	27.68
	25	35.8	12.63	42.8	15.85	49.7	19.43	53.1	21.39	56.5	23.40	63.4	27.78	66.0	28.90
	27	35.8	13.42	42.8	16.87	49.7	20.74	53.1	22.84	56.5	25.03	63.4	29.73	64.9	30.11
	29	35.8	14.31	42.8	17.99	49.7	22.14	53.1	24.37	56.5	26.75	62.8	31.09	64.1	31.32
	31	35.8	15.19	42.8	19.16	49.7	23.58	53.1	26.01	56.5	28.52	61.7	32.30	63.0	32.58
	33	35.8	16.12	42.8	20.37	49.7	25.17	53.1	27.73	56.5	30.43	60.9	33.56	62.2	33.79
35	35.8	17.15	42.8	21.67	49.7	26.80	53.1	29.55	56.5	32.44	59.8	34.77	61.1	35.05	
37	35.8	18.18	42.8	23.02	49.7	28.52	53.1	31.46	56.5	34.58	58.8	35.98	60.3	36.26	
39	35.8	19.30	42.8	24.52	49.7	30.34	53.1	33.51	56.5	36.82	57.9	37.24	59.2	37.52	
41	35.8	19.96	42.8	25.62	49.7	31.45	53.1	34.40	56.5	37.04	57.5	38.19	58.8	38.40	
43	35.8	20.92	42.8	26.73	49.7	32.56	53.1	35.28	56.5	37.83	57.2	38.68	58.3	39.00	
45	35.8	22.25	42.8	28.06	49.7	33.89	53.1	36.47	56.5	38.88	56.9	39.09	57.4	39.52	
48	35.8	23.49	42.8	29.36	49.7	35.16	53.1	36.93	56.5	39.21	56.5	39.63	55.9	40.05	
80%	-5	31.8	8.46	37.9	10.01	44.0	11.85	47.2	12.59	50.4	13.57	56.5	15.68	62.6	17.90
	-2	31.8	8.59	37.9	10.13	44.0	11.95	47.2	12.79	50.4	13.69	56.5	15.83	62.6	18.07
	0	31.8	8.74	37.9	10.25	44.0	12.10	47.2	12.94	50.4	13.94	56.5	16.05	62.6	18.32
	2	31.8	8.91	37.9	10.40	44.0	12.27	47.2	13.19	50.4	14.19	56.5	16.38	62.6	18.67
	4	31.8	9.06	37.9	10.58	44.0	12.50	47.2	13.49	50.4	14.44	56.5	16.68	62.6	18.92
	6	31.8	9.21	37.9	10.83	44.0	12.69	47.2	13.79	50.4	14.71	56.5	16.93	62.6	19.24
	8	31.8	9.38	37.9	11.08	44.0	12.99	47.2	14.01	50.4	15.03	56.5	17.17	62.6	19.61
	10	31.8	9.46	37.9	11.33	44.0	13.33	47.2	14.36	50.4	15.38	56.5	17.57	62.6	19.81
	12	31.8	9.60	37.9	11.51	44.0	13.56	47.2	14.64	50.4	15.71	56.5	17.90	62.6	20.18
	14	31.8	9.79	37.9	11.75	44.0	13.80	47.2	14.87	50.4	15.99	56.5	18.22	62.6	20.55
	16	31.8	9.93	37.9	11.93	44.0	14.08	47.2	15.15	50.4	16.27	56.5	18.60	62.6	20.93
	18	31.8	10.12	37.9	12.17	44.0	14.36	47.2	15.47	50.4	16.59	56.5	18.97	62.6	21.35
	20	31.8	10.30	37.9	12.40	44.0	14.64	47.2	15.76	50.4	16.92	56.5	19.67	62.6	22.84
	21	31.8	10.39	37.9	12.49	44.0	14.77	47.2	15.94	50.4	17.29	56.5	20.37	62.6	23.68
	23	31.8	10.58	37.9	12.77	44.0	15.47	47.2	16.97	50.4	18.50	56.5	21.81	62.6	25.40
	25	31.8	10.91	37.9	13.56	44.0	16.55	47.2	18.13	50.4	19.76	56.5	23.35	62.6	27.17
	27	31.8	11.61	37.9	14.45	44.0	17.62	47.2	19.34	50.4	21.11	56.5	24.94	62.6	29.08
	29	31.8	12.35	37.9	15.38	44.0	18.78	47.2	20.60	50.4	22.56	56.5	26.61	62.6	31.09
	31	31.8	13.10	37.9	16.36	44.0	20.00	47.2	21.95	50.4	24.05	56.5	28.43	61.5	32.30
	33	31.8	13.94	37.9	17.39	44.0	21.30	47.2	23.40	50.4	25.59	56.5	30.30	60.7	33.51
35	31.8	14.77	37.9	18.50	44.0	22.65	47.2	24.89	50.4	27.27	56.5	32.30	59.6	34.72	
37	31.8	15.66	37.9	19.62	44.0	24.10	47.2	26.52	50.4	29.04	56.5	34.45	58.8	35.94	
39	31.8	16.59	37.9	20.93	44.0	25.64	47.2	28.20	50.4	30.90	56.5	36.68	57.7	37.20	
41	31.8	16.97	37.9	21.11	44.0	26.01	47.2	28.95	50.4	31.46	56.5	37.62	57.4	37.85	
43	31.8	17.47	37.9	21.30	44.0	26.38	47.2	29.44	50.4	31.90	56.5	38.05	57.0	38.25	
45	31.8	17.96	37.9	21.55	44.0	26.89	47.2	30.07	50.4	32.45	56.5	38.47	56.3	38.88	
48	31.8	18.54	37.9	21.68	44.0	27.30	47.2	30.47	50.4	32.71	56.5	38.83	55.8	39.38	

Abbreviations:

CR: Combination ratio

TC: Total capacity (kW)

PI: Power input (compressor + outdoor fan motor) (kW)

Notes:

Shaded cells indicate rating condition.

Table continued on next page ...

Table 2-8.8: 22HP cooling capacity (continued)

Combination (%) (Capacity index)	Outdoor temperature (°C DB)	Indoor temperature(°C DB/WB)													
		DB:20.8,WB:14		DB:23.3,WB:16		DB:25.8,WB:18		DB:27,WB:19		DB:28.2,WB:20		DB:30.7,WB:22		DB:32,WB:24	
		TC kW	PI kW	TC kW	PI kW	TC kW	PI kW	TC kW	PI kW	TC kW	PI kW	TC kW	PI kW	TC kW	PI kW
70%	-5	27.8	7.55	33.3	8.86	38.6	10.04	41.3	10.76	44.0	11.49	49.3	13.14	54.8	15.11
	-2	27.8	7.62	33.3	8.90	38.6	10.10	41.3	10.97	44.0	11.69	49.3	13.35	54.8	15.31
	0	27.8	7.66	33.3	9.02	38.6	10.31	41.3	11.18	44.0	11.90	49.3	13.62	54.8	15.52
	2	27.8	7.70	33.3	9.06	38.6	10.47	41.3	11.38	44.0	12.11	49.3	13.91	54.8	15.77
	4	27.8	7.80	33.3	9.29	38.6	10.70	41.3	11.59	44.0	12.38	49.3	14.13	54.8	16.14
	6	27.8	7.93	33.3	9.45	38.6	10.97	41.3	11.96	44.0	12.67	49.3	14.38	54.8	16.45
	8	27.8	8.07	33.3	9.73	38.6	11.22	41.3	12.15	44.0	12.93	49.3	14.80	54.8	16.76
	10	27.8	8.24	33.3	9.88	38.6	11.51	41.3	12.40	44.0	13.28	49.3	15.10	54.8	16.97
	12	27.8	8.44	33.3	10.02	38.6	11.75	41.3	12.63	44.0	13.52	49.3	15.38	54.8	17.29
	14	27.8	8.58	33.3	10.21	38.6	11.93	41.3	12.82	44.0	13.75	49.3	15.66	54.8	17.62
	16	27.8	8.72	33.3	10.40	38.6	12.16	41.3	13.10	44.0	14.03	49.3	15.94	54.8	17.94
	18	27.8	8.86	33.3	10.58	38.6	12.40	41.3	13.33	44.0	14.26	49.3	16.27	54.8	18.32
	20	27.8	9.00	33.3	10.77	38.6	12.63	41.3	13.56	44.0	14.54	49.3	16.59	54.8	18.83
	21	27.8	9.09	33.3	10.86	38.6	12.73	41.3	13.70	44.0	14.68	49.3	16.83	54.8	19.48
	23	27.8	9.23	33.3	11.05	38.6	13.00	41.3	14.17	44.0	15.43	49.3	18.04	54.8	20.88
	25	27.8	9.42	33.3	11.51	38.6	13.84	41.3	15.15	44.0	16.45	49.3	19.30	54.8	22.33
	27	27.8	9.98	33.3	12.26	38.6	14.78	41.3	16.13	44.0	17.57	49.3	20.60	54.8	23.87
	29	27.8	10.58	33.3	13.00	38.6	15.71	41.3	17.20	44.0	18.69	49.3	21.95	54.8	25.50
	31	27.8	11.19	33.3	13.80	38.6	16.73	41.3	18.27	44.0	19.90	49.3	23.40	54.8	27.17
	33	27.8	11.89	33.3	14.68	38.6	17.81	41.3	19.44	44.0	21.21	49.3	24.94	54.8	28.99
35	27.8	12.58	33.3	15.57	38.6	18.88	41.3	20.70	44.0	22.56	49.3	26.57	54.8	30.90	
37	27.8	13.28	33.3	16.50	38.6	20.09	41.3	21.95	44.0	24.00	49.3	28.29	54.8	32.91	
39	27.8	14.08	33.3	17.48	38.6	21.30	41.3	23.35	44.0	25.50	49.3	30.06	54.8	35.05	
41	27.8	14.70	33.3	18.10	38.6	21.92	41.3	24.13	44.0	26.27	49.3	31.31	54.8	36.60	
43	27.8	15.89	33.3	19.34	38.6	22.83	41.3	25.42	44.0	27.05	49.3	32.44	54.8	37.74	
45	27.8	16.25	33.3	19.76	38.6	23.30	41.3	25.84	44.0	28.39	49.3	34.20	54.8	39.19	
48	27.8	16.56	33.3	19.87	38.6	23.59	41.3	26.28	44.0	29.18	49.3	35.80	54.8	40.15	
60%	-5	23.8	6.44	28.4	7.47	33.1	8.71	35.4	9.28	37.7	10.02	42.4	11.25	47.0	12.91
	-2	23.8	6.48	28.4	7.59	33.1	8.87	35.4	9.41	37.7	10.12	42.4	11.42	47.0	12.99
	0	23.8	6.58	28.4	7.68	33.1	8.98	35.4	9.53	37.7	10.29	42.4	11.59	47.0	13.16
	2	23.8	6.70	28.4	7.86	33.1	9.15	35.4	9.72	37.7	10.43	42.4	11.83	47.0	13.33
	4	23.8	6.88	28.4	8.01	33.1	9.33	35.4	9.84	37.7	10.58	42.4	12.01	47.0	13.51
	6	23.8	6.95	28.4	8.17	33.1	9.51	35.4	10.05	37.7	10.80	42.4	12.25	47.0	13.83
	8	23.8	7.09	28.4	8.30	33.1	9.69	35.4	10.24	37.7	11.02	42.4	12.48	47.0	14.05
	10	23.8	7.22	28.4	8.48	33.1	9.83	35.4	10.53	37.7	11.23	42.4	12.72	47.0	14.26
	12	23.8	7.36	28.4	8.62	33.1	10.02	35.4	10.72	37.7	11.42	42.4	12.96	47.0	14.49
	14	23.8	7.46	28.4	8.76	33.1	10.16	35.4	10.90	37.7	11.65	42.4	13.19	47.0	14.77
	16	23.8	7.55	28.4	8.90	33.1	10.35	35.4	11.09	37.7	11.84	42.4	13.42	47.0	15.05
	18	23.8	7.69	28.4	9.04	33.1	10.53	35.4	11.28	37.7	12.07	42.4	13.65	47.0	15.33
	20	23.8	7.78	28.4	9.23	33.1	10.72	35.4	11.51	37.7	12.30	42.4	13.93	47.0	15.66
	21	23.8	7.88	28.4	9.27	33.1	10.81	35.4	11.60	37.7	12.40	42.4	14.07	47.0	15.80
	23	23.8	7.97	28.4	9.46	33.1	11.00	35.4	11.84	37.7	12.63	42.4	14.63	47.0	16.82
	25	23.8	8.11	28.4	9.60	33.1	11.42	35.4	12.40	37.7	13.42	42.4	15.61	47.0	17.94
	27	23.8	8.44	28.4	10.21	33.1	12.16	35.4	13.23	37.7	14.31	42.4	16.64	47.0	19.15
	29	23.8	8.90	28.4	10.81	33.1	12.96	35.4	14.07	37.7	15.24	42.4	17.76	47.0	20.46
	31	23.8	9.46	28.4	11.46	33.1	13.75	35.4	14.96	37.7	16.22	42.4	18.87	47.0	21.76
	33	23.8	9.97	28.4	12.16	33.1	14.59	35.4	15.89	37.7	17.24	42.4	20.09	47.0	23.21
35	23.8	10.58	28.4	12.91	33.1	15.47	35.4	16.87	37.7	18.31	42.4	21.39	47.0	24.70	
37	23.8	11.18	28.4	13.65	33.1	16.40	35.4	17.90	37.7	19.43	42.4	22.74	47.0	26.28	
39	23.8	11.79	28.4	14.45	33.1	17.38	35.4	18.97	37.7	20.65	42.4	24.14	47.0	27.96	
41	23.8	12.17	28.4	15.07	33.1	18.02	35.4	19.73	37.7	21.40	42.4	25.28	47.0	29.23	
43	23.8	12.55	28.4	15.71	33.1	18.65	35.4	20.32	37.7	22.15	42.4	26.35	47.0	30.49	
45	23.8	13.14	28.4	16.50	33.1	19.41	35.4	21.08	37.7	23.25	42.4	27.53	47.0	32.18	
48	23.8	13.63	28.4	17.21	33.1	20.08	35.4	21.59	37.7	24.12	42.4	28.51	47.0	33.74	

Abbreviations:
 CR: Combination ratio
 TC: Total capacity (kW)
 PI: Power input (compressor + outdoor fan motor) (kW)

Notes:
 Shaded cells indicate rating condition.

Table continued on next page ...

Table 2-8.8: 22HP cooling capacity (continued)

Combination (%) (Capacity index)	Outdoor temperature (°C DB)	Indoor temperature(°C DB/WB)													
		DB:20.8,WB:14		DB:23.3,WB:16		DB:25.8,WB:18		DB:27,WB:19		DB:28.2,WB:20		DB:30.7,WB:22		DB:32,WB:24	
		TC	PI	TC	PI	TC	PI	TC	PI	TC	PI	TC	PI	TC	PI
50%	-5	19.9	5.60	23.8	6.47	27.6	7.44	29.5	7.78	31.4	8.21	35.2	9.34	39.2	10.07
	-2	19.9	5.64	23.8	6.60	27.6	7.52	29.5	7.89	31.4	8.36	35.2	9.46	39.2	10.20
	0	19.9	5.73	23.8	6.71	27.6	7.65	29.5	8.00	31.4	8.46	35.2	9.62	39.2	10.38
	2	19.9	5.81	23.8	6.79	27.6	7.78	29.5	8.12	31.4	8.60	35.2	9.66	39.2	10.58
	4	19.9	5.87	23.8	6.91	27.6	7.87	29.5	8.21	31.4	8.78	35.2	9.91	39.2	10.85
	6	19.9	5.98	23.8	7.02	27.6	7.99	29.5	8.40	31.4	8.94	35.2	10.06	39.2	11.17
	8	19.9	6.12	23.8	7.14	27.6	8.12	29.5	8.59	31.4	9.06	35.2	10.22	39.2	11.53
	10	19.9	6.25	23.8	7.22	27.6	8.25	29.5	8.72	31.4	9.32	35.2	10.49	39.2	11.70
	12	19.9	6.29	23.8	7.32	27.6	8.39	29.5	8.90	31.4	9.51	35.2	10.67	39.2	11.88
	14	19.9	6.38	23.8	7.41	27.6	8.48	29.5	9.09	31.4	9.65	35.2	10.86	39.2	12.12
	16	19.9	6.48	23.8	7.50	27.6	8.62	29.5	9.23	31.4	9.79	35.2	11.04	39.2	12.30
	18	19.9	6.57	23.8	7.64	27.6	8.76	29.5	9.37	31.4	9.97	35.2	11.23	39.2	12.54
	20	19.9	6.66	23.8	7.74	27.6	8.90	29.5	9.51	31.4	10.16	35.2	11.42	39.2	12.77
	21	19.9	6.71	23.8	7.83	27.6	8.99	29.5	9.60	31.4	10.25	35.2	11.56	39.2	12.91
	23	19.9	6.80	23.8	7.92	27.6	9.14	29.5	9.79	31.4	10.44	35.2	11.74	39.2	13.19
	25	19.9	6.90	23.8	8.06	27.6	9.32	29.5	9.97	31.4	10.77	35.2	12.35	39.2	14.07
	27	19.9	7.04	23.8	8.39	27.6	9.83	29.5	10.63	31.4	11.42	35.2	13.14	39.2	15.01
	29	19.9	7.41	23.8	8.85	27.6	10.44	29.5	11.28	31.4	12.16	35.2	13.98	39.2	15.99
	31	19.9	7.83	23.8	9.37	27.6	11.04	29.5	11.98	31.4	12.91	35.2	14.87	39.2	17.01
	33	19.9	8.30	23.8	9.93	27.6	11.74	29.5	12.68	31.4	13.70	35.2	15.80	39.2	18.08
35	19.9	8.76	23.8	10.49	27.6	12.40	29.5	13.42	31.4	14.50	35.2	16.78	39.2	19.20	
37	19.9	9.23	23.8	11.09	27.6	13.14	29.5	14.21	31.4	15.38	35.2	17.80	39.2	20.41	
39	19.9	9.74	23.8	11.70	27.6	13.89	29.5	15.05	31.4	16.31	35.2	18.88	39.2	21.67	
41	19.9	10.14	23.8	12.20	27.6	14.39	29.5	15.76	31.4	17.02	35.2	19.88	39.2	22.68	
43	19.9	10.81	23.8	13.04	27.6	14.89	29.5	16.46	31.4	17.45	35.2	20.89	39.2	23.68	
45	19.9	11.06	23.8	13.38	27.6	15.90	29.5	17.74	31.4	18.19	35.2	22.90	39.2	25.70	
48	19.9	11.27	23.8	13.69	27.6	16.78	29.5	18.93	31.4	19.06	35.2	24.70	39.2	27.65	

Abbreviations:

CR: Combination ratio

TC: Total capacity (kW)

PI: Power input (compressor + outdoor fan motor) (kW)

Notes:

Shaded cells indicate rating condition.

Table 2-8.9: 24HP cooling capacity

Combination (%) (Capacity index)	Outdoor temperature (°C DB)	Indoor temperature(°C DB/WB)													
		DB:20.8,WB:14		DB:23.3,WB:16		DB:25.8,WB:18		DB:27,WB:19		DB:28.2,WB:20		DB:30.7,WB:22		DB:32,WB:24	
		TC	PI	TC	PI	TC	PI	TC	PI	TC	PI	TC	PI	TC	PI
130%	-5	58.9	13.02	70.1	15.89	81.4	17.03	84.5	17.72	88.5	18.23	90.7	19.82	93.0	19.95
	-2	58.9	13.02	70.1	16.20	81.4	17.03	84.5	17.83	88.5	18.23	90.7	20.07	93.0	20.15
	0	58.9	13.24	70.1	16.48	81.4	17.66	84.5	18.81	88.5	19.29	90.7	20.32	93.0	20.41
	2	58.9	13.48	70.1	16.51	81.4	18.26	84.5	19.87	88.5	19.51	90.7	20.47	93.0	20.72
	4	58.9	13.78	70.1	16.83	81.4	18.89	84.5	19.95	88.5	19.76	90.7	20.78	93.0	21.11
	6	58.9	14.05	70.1	17.17	81.4	19.59	84.5	20.12	87.5	20.38	89.6	21.10	91.9	21.27
	8	58.9	14.38	70.1	17.56	81.4	20.57	84.5	21.10	86.5	21.04	88.6	21.17	90.8	21.47
	10	58.9	14.68	70.1	17.94	81.4	21.33	84.5	21.81	85.4	21.43	87.6	21.49	89.7	22.09
	12	58.9	14.94	70.1	18.28	81.4	21.76	83.3	22.13	84.5	21.76	86.4	21.82	88.5	22.23
	14	58.9	15.24	70.1	18.63	81.1	22.08	82.3	22.46	83.3	22.08	85.4	22.14	87.6	22.74
	16	58.9	15.50	70.1	19.01	80.2	22.41	81.1	22.75	82.1	22.73	84.2	22.47	86.4	23.10
	18	58.9	15.79	70.1	19.40	79.0	22.75	79.9	22.88	81.1	23.01	83.3	23.22	85.4	23.44
	20	58.9	16.14	70.1	20.65	77.8	23.87	79.0	23.99	79.9	24.12	82.1	24.34	84.2	24.59
	21	58.9	16.57	70.1	21.38	77.3	24.42	78.5	24.55	79.4	24.68	81.6	24.94	83.7	25.15
	23	58.9	17.77	70.1	22.92	76.3	25.54	77.3	25.67	78.2	25.80	80.4	26.05	82.5	26.31
	25	58.9	18.97	70.1	24.55	75.1	26.65	76.1	26.78	77.3	26.96	79.4	27.21	81.6	27.47
	27	58.9	20.26	70.1	26.27	74.2	27.77	75.1	27.94	76.1	28.07	78.2	28.37	80.4	28.67
	29	58.9	21.63	70.1	28.07	73.0	28.89	73.9	29.06	75.1	29.23	77.3	29.53	79.4	29.83
	31	58.9	23.09	69.9	29.70	71.8	30.05	73.0	30.21	73.9	30.34	76.1	30.69	78.2	31.03
	33	58.9	24.59	68.7	30.82	70.8	31.16	71.8	31.33	73.0	31.50	75.1	31.85	77.0	32.19
35	58.9	26.22	67.5	31.93	69.6	32.32	70.8	32.49	71.8	32.66	73.9	33.05	76.1	33.39	
37	58.9	27.90	66.5	33.09	68.7	33.48	69.6	33.65	70.8	33.87	72.7	34.25	74.9	34.64	
39	58.9	29.70	65.3	33.44	67.5	34.59	68.7	34.81	69.6	35.02	71.8	35.41	73.9	35.84	
41	58.9	31.26	64.6	33.76	66.8	34.92	68.0	35.13	68.9	35.35	71.1	35.48	71.1	36.16	
43	58.9	32.06	64.2	33.92	66.4	35.02	67.6	35.30	68.2	35.40	69.8	35.55	70.3	36.24	
45	58.9	33.65	63.8	34.25	65.7	35.34	66.9	35.52	67.2	35.56	67.9	35.68	68.9	36.93	
48	58.9	34.81	63.6	35.34	64.6	35.64	65.8	35.82	66.4	35.94	66.1	36.29	67.3	37.06	
120%	-5	54.3	12.57	64.6	15.23	75.1	18.01	80.4	19.64	84.2	20.47	86.1	21.13	88.1	21.69
	-2	54.3	12.70	64.6	15.39	75.1	18.19	80.4	19.75	84.2	20.71	86.1	21.30	88.1	21.76
	0	54.3	12.81	64.6	15.49	75.1	18.40	80.4	19.80	84.2	20.90	86.1	21.43	88.1	21.81
	2	54.3	12.85	64.6	15.65	75.1	18.53	80.4	19.99	84.2	20.98	86.1	21.59	88.1	21.85
	4	54.3	12.97	64.6	15.85	75.1	18.78	80.4	20.17	84.2	21.26	86.1	21.63	88.1	21.91
	6	54.3	13.11	64.6	15.98	75.1	19.01	80.4	20.40	84.2	21.49	86.1	21.81	88.1	21.98
	8	54.3	13.23	64.6	16.14	75.1	19.27	80.4	20.66	84.2	21.71	86.1	21.88	88.1	22.09
	10	54.3	13.39	64.6	16.35	75.1	19.44	80.4	21.03	84.2	21.72	86.1	21.95	88.1	22.18
	12	54.3	13.65	64.6	16.65	75.1	19.83	80.4	21.42	83.0	21.81	84.9	21.82	86.9	22.32
	14	54.3	13.91	64.6	17.00	75.1	20.21	80.4	21.85	81.8	21.95	84.0	22.16	85.9	22.59
	16	54.3	14.16	64.6	17.34	75.1	20.60	79.9	22.23	80.9	22.27	82.8	22.53	84.7	22.94
	18	54.3	14.42	64.6	17.68	75.1	21.29	78.7	22.75	79.7	22.83	81.6	23.05	83.7	23.26
	20	54.3	14.72	64.6	18.37	75.1	22.92	77.8	23.86	78.7	23.95	80.6	24.16	82.6	24.38
	21	54.3	14.85	64.6	19.01	75.1	23.74	77.0	24.42	78.0	24.51	80.2	24.72	82.1	24.98
	23	54.3	15.88	64.6	20.39	75.1	25.41	76.1	25.49	77.0	25.62	79.0	25.88	80.9	26.09
	25	54.3	16.95	64.6	21.80	73.9	26.52	74.9	26.61	75.9	26.74	78.0	27.00	79.9	27.25
	27	54.3	18.11	64.6	23.31	73.0	27.60	73.9	27.77	74.9	27.90	76.8	28.15	78.7	28.41
	29	54.3	19.31	64.6	24.89	71.8	28.71	72.7	28.88	73.7	29.01	75.6	29.31	77.8	29.57
	31	54.3	20.60	64.6	26.57	70.6	29.87	71.8	30.00	72.7	30.17	74.7	30.47	76.6	30.77
	33	54.3	21.93	64.6	28.33	69.6	30.99	70.6	31.16	71.5	31.29	73.5	31.63	75.4	31.93
35	54.3	23.35	64.6	30.22	68.4	32.10	69.4	32.28	70.6	32.45	72.5	32.79	74.4	33.13	
37	54.3	24.85	64.6	32.19	67.5	33.26	68.4	33.43	69.4	33.61	71.3	33.95	73.2	34.33	
39	54.3	26.44	64.4	33.99	66.3	34.38	67.2	34.59	68.2	34.76	70.3	35.15	72.3	35.49	
41	54.3	27.16	63.8	34.23	65.8	34.62	66.7	34.83	67.7	35.01	69.8	35.25	70.2	35.76	
43	54.3	27.57	63.5	34.48	65.2	34.83	66.2	34.97	67.2	35.13	68.6	35.34	69.1	36.48	
45	54.3	27.89	63.2	34.80	64.6	35.15	65.5	35.30	66.6	35.40	67.2	35.45	68.4	37.27	
48	54.3	28.08	62.6	35.18	63.8	35.46	64.5	35.50	65.8	35.73	66.2	35.83	67.5	37.73	

Abbreviations:

CR: Combination ratio

TC: Total capacity (kW)

PI: Power input (compressor + outdoor fan motor) (kW)

Notes:

Shaded cells indicate rating condition.

Table continued on next page ...

Table 2-8.9: 24HP cooling capacity (continued)

Combination (%) (Capacity index)	Outdoor temperature (°C DB)	Indoor temperature(°C DB/WB)													
		DB:20.8,WB:14		DB:23.3,WB:16		DB:25.8,WB:18		DB:27,WB:19		DB:28.2,WB:20		DB:30.7,WB:22		DB:32,WB:24	
		TC kW	PI kW	TC kW	PI kW	TC kW	PI kW	TC kW	PI kW	TC kW	PI kW	TC kW	PI kW	TC kW	PI kW
110%	-5	49.8	10.98	59.3	13.67	68.9	16.31	73.7	17.51	78.5	18.84	84.5	19.56	86.4	20.17
	-2	49.8	11.19	59.3	13.84	68.9	16.45	73.7	17.68	78.5	18.98	84.5	19.76	86.4	20.28
	0	49.8	11.30	59.3	13.92	68.9	16.57	73.7	17.79	78.5	19.20	84.5	19.95	86.4	20.52
	2	49.8	11.55	59.3	14.06	68.9	16.83	73.7	17.99	78.5	19.40	84.5	20.24	86.4	20.78
	4	49.8	11.78	59.3	14.22	68.9	16.99	73.7	18.21	78.5	19.70	84.5	20.52	86.4	20.97
	6	49.8	11.90	59.3	14.38	68.9	17.16	73.7	18.50	78.5	19.92	84.5	20.73	86.4	21.29
	8	49.8	12.00	59.3	14.61	68.9	17.35	73.7	18.69	78.5	20.14	84.5	20.88	86.4	21.51
	10	49.8	12.15	59.3	14.81	68.9	17.60	73.7	19.01	78.5	20.47	84.5	21.02	86.4	21.70
	12	49.8	12.40	59.3	15.11	68.9	17.94	73.7	19.40	78.5	20.86	83.5	21.33	85.2	21.98
	14	49.8	12.62	59.3	15.37	68.9	18.29	73.7	19.74	78.5	21.25	82.3	21.50	84.2	22.14
	16	49.8	12.83	59.3	15.67	68.9	18.63	73.7	20.13	78.5	21.67	81.4	21.76	83.0	22.38
	18	49.8	13.09	59.3	15.97	68.9	19.01	73.7	20.69	78.5	22.11	80.2	22.88	82.1	23.09
	20	49.8	13.35	59.3	16.31	68.9	20.13	73.7	22.23	77.3	23.82	79.2	23.99	80.9	24.21
	21	49.8	13.48	59.3	16.78	68.9	20.86	73.7	23.05	76.8	24.38	78.5	24.55	80.4	24.76
	23	49.8	14.12	59.3	17.98	68.9	22.36	73.7	24.72	75.6	25.45	77.5	25.70	79.2	25.93
	25	49.8	15.07	59.3	19.23	68.9	23.91	73.7	26.48	74.7	26.57	76.3	26.83	78.2	27.04
	27	49.8	16.05	59.3	20.56	68.9	25.58	72.5	27.60	73.5	27.69	75.4	27.94	77.1	28.20
	29	49.8	17.12	59.3	21.93	68.9	27.34	71.5	28.71	72.5	28.84	74.2	29.10	76.1	29.36
	31	49.8	18.24	59.3	23.39	68.9	29.19	70.4	29.83	71.3	29.96	73.2	30.22	74.9	30.52
	33	49.8	19.40	59.3	24.94	68.4	30.77	69.4	30.95	70.4	31.07	72.0	31.38	73.9	31.68
35	49.8	20.64	59.3	26.57	67.2	31.89	68.2	32.06	69.2	32.24	70.8	32.53	72.7	32.83	
37	49.8	21.98	59.3	28.29	66.3	33.05	67.2	33.18	68.0	33.35	69.9	33.69	71.5	33.99	
39	49.8	23.35	59.3	30.13	65.1	34.17	66.0	34.34	67.0	34.51	68.7	34.85	70.6	35.19	
41	49.8	23.59	59.3	30.37	64.6	34.41	65.5	34.58	66.5	34.75	67.8	35.09	68.5	35.44	
43	49.8	23.83	59.3	30.76	64.1	34.65	65.0	34.82	66.0	34.99	67.2	35.22	67.4	36.16	
45	49.8	24.60	59.3	30.93	63.4	34.97	64.3	35.24	65.4	35.31	66.5	36.18	66.8	36.99	
48	49.8	25.41	59.3	33.49	62.5	35.13	63.3	35.41	64.7	35.62	65.4	36.24	65.9	37.31	
100%	-5	45.2	10.00	53.8	12.04	62.7	14.33	67.0	15.35	71.3	16.66	80.2	18.98	84.7	19.81
	-2	45.2	10.12	53.8	12.20	62.7	14.49	67.0	15.64	71.3	16.88	80.2	19.20	84.7	19.94
	0	45.2	10.22	53.8	12.32	62.7	14.65	67.0	15.83	71.3	17.04	80.2	19.52	84.7	20.16
	2	45.2	10.43	53.8	12.49	62.7	14.81	67.0	16.03	71.3	17.23	80.2	19.81	84.7	20.48
	4	45.2	10.50	53.8	12.61	62.7	15.03	67.0	16.27	71.3	17.45	80.2	20.00	84.7	20.70
	6	45.2	10.65	53.8	12.87	62.7	15.22	67.0	16.56	71.3	17.71	80.2	20.29	84.7	21.02
	8	45.2	10.86	53.8	13.06	62.7	15.50	67.0	16.75	71.3	17.99	80.2	20.60	84.7	21.37
	10	45.2	10.99	53.8	13.31	62.7	15.75	67.0	17.04	71.3	18.33	80.2	20.94	84.7	21.67
	12	45.2	11.16	53.8	13.56	62.7	16.05	67.0	17.34	71.3	18.67	80.2	21.33	83.5	21.84
	14	45.2	11.37	53.8	13.82	62.7	16.35	67.0	17.68	71.3	19.01	80.2	21.76	82.6	22.11
	16	45.2	11.59	53.8	14.08	62.7	16.70	67.0	18.02	71.3	19.40	79.7	22.02	81.4	22.36
	18	45.2	11.80	53.8	14.33	62.7	17.00	67.0	18.37	71.3	19.79	78.7	22.75	80.4	22.92
	20	45.2	12.02	53.8	14.64	62.7	17.51	67.0	19.31	71.3	21.20	77.5	23.82	79.2	24.03
	21	45.2	12.15	53.8	14.76	62.7	18.16	67.0	20.00	71.3	21.93	77.1	24.38	78.7	24.59
	23	45.2	12.45	53.8	15.75	62.7	19.44	67.0	21.42	71.3	23.52	76.1	25.49	77.5	25.71
	25	45.2	13.26	53.8	16.82	62.7	20.81	67.0	22.96	71.3	25.19	74.9	26.61	76.6	26.82
	27	45.2	14.16	53.8	17.94	62.7	22.23	67.0	24.55	71.3	26.95	73.7	27.72	75.4	27.98
	29	45.2	15.06	53.8	19.14	62.7	23.73	67.0	26.22	71.1	28.63	72.7	28.88	74.4	29.10
	31	45.2	16.05	53.8	20.43	62.7	25.32	67.0	27.98	70.1	29.74	71.5	30.00	73.2	30.26
	33	45.2	17.04	53.8	21.76	62.7	27.00	67.0	29.87	68.9	30.86	70.6	31.12	72.3	31.42
35	45.2	18.11	53.8	23.13	62.7	28.80	67.0	31.85	67.7	31.97	69.4	32.27	71.1	32.53	
37	45.2	19.27	53.8	24.64	62.7	30.69	65.8	32.96	66.8	33.13	68.4	33.43	69.9	33.69	
39	45.2	20.47	53.8	26.18	62.7	32.66	64.8	34.08	65.6	34.25	67.2	34.55	68.9	34.89	
41	45.2	21.43	53.8	27.14	62.7	33.86	63.8	34.32	65.1	34.78	66.1	35.36	67.9	35.61	
43	45.2	22.38	53.8	28.09	62.7	34.48	62.8	34.71	64.6	35.11	66.5	35.59	66.7	36.01	
45	45.2	23.65	53.8	29.36	62.7	35.07	61.5	35.19	64.3	35.75	65.9	36.14	65.4	36.49	
48	45.2	24.70	53.8	30.39	62.7	35.13	59.0	35.59	64.2	36.38	61.9	36.52	63.9	36.83	

Abbreviations:

CR: Combination ratio

TC: Total capacity (kW)

PI: Power input (compressor + outdoor fan motor) (kW)

Notes:

Shaded cells indicate rating condition.

Table continued on next page ...

Table 2-8.9: 24HP cooling capacity (continued)

Combination (%) (Capacity index)	Outdoor temperature (°C DB)	Indoor temperature(°C DB/WB)													
		DB:20.8,WB:14		DB:23.3,WB:16		DB:25.8,WB:18		DB:27,WB:19		DB:28.2,WB:20		DB:30.7,WB:22		DB:32,WB:24	
		TC	PI	TC	PI	TC	PI	TC	PI	TC	PI	TC	PI	TC	PI
90%	-5	40.7	8.84	48.6	10.61	56.5	12.52	60.3	13.66	64.1	14.53	72.0	16.71	79.9	19.13
	-2	40.7	8.92	48.6	10.72	56.5	12.68	60.3	13.85	64.1	14.71	72.0	16.87	79.9	19.32
	0	40.7	9.06	48.6	10.86	56.5	12.87	60.3	14.01	64.1	14.89	72.0	17.06	79.9	19.47
	2	40.7	9.20	48.6	10.99	56.5	13.01	60.3	14.23	64.1	15.13	72.0	17.41	79.9	19.75
	4	40.7	9.34	48.6	11.16	56.5	13.22	60.3	14.42	64.1	15.32	72.0	17.69	79.9	20.04
	6	40.7	9.46	48.6	11.37	56.5	13.47	60.3	14.69	64.1	15.59	72.0	17.96	79.9	20.38
	8	40.7	9.65	48.6	11.59	56.5	13.74	60.3	14.88	64.1	15.86	72.0	18.29	79.9	20.57
	10	40.7	9.83	48.6	11.84	56.5	13.99	60.3	15.11	64.1	16.22	72.0	18.53	79.9	20.90
	12	40.7	10.00	48.6	12.06	56.5	14.25	60.3	15.36	64.1	16.52	72.0	18.88	79.9	21.29
	14	40.7	10.17	48.6	12.27	56.5	14.51	60.3	15.66	64.1	16.82	72.0	19.23	79.9	21.67
	16	40.7	10.34	48.6	12.49	56.5	14.81	60.3	15.97	64.1	17.17	72.0	19.61	79.7	22.06
	18	40.7	10.51	48.6	12.75	56.5	15.06	60.3	16.27	64.1	17.51	72.0	20.00	78.7	22.75
	20	40.7	10.73	48.6	13.04	56.5	15.36	60.3	16.61	64.1	18.15	72.0	21.50	77.5	23.82
	21	40.7	10.82	48.6	13.13	56.5	15.62	60.3	17.17	64.1	18.80	72.0	22.27	77.1	24.38
	23	40.7	11.03	48.6	13.65	56.5	16.74	60.3	18.41	64.1	20.17	72.0	23.90	75.9	25.49
	25	40.7	11.63	48.6	14.59	56.5	17.90	60.3	19.70	64.1	21.54	72.0	25.58	74.9	26.61
	27	40.7	12.36	48.6	15.54	56.5	19.10	60.3	21.03	64.1	23.05	72.0	27.38	73.7	27.72
	29	40.7	13.17	48.6	16.56	56.5	20.38	60.3	22.44	64.1	24.63	71.3	28.63	72.7	28.84
	31	40.7	13.99	48.6	17.64	56.5	21.72	60.3	23.95	64.1	26.26	70.1	29.74	71.5	30.00
	33	40.7	14.85	48.6	18.76	56.5	23.17	60.3	25.53	64.1	28.03	69.2	30.90	70.6	31.11
35	40.7	15.79	48.6	19.96	56.5	24.68	60.3	27.21	64.1	29.87	68.0	32.02	69.4	32.27	
37	40.7	16.74	48.6	21.20	56.5	26.26	60.3	28.97	64.1	31.84	66.8	33.13	68.4	33.39	
39	40.7	17.77	48.6	22.58	56.5	27.94	60.3	30.86	64.1	33.91	65.8	34.29	67.2	34.55	
41	40.7	18.38	48.6	23.60	56.5	28.96	60.3	31.67	64.1	34.11	65.3	35.16	66.8	35.36	
43	40.7	19.26	48.6	24.62	56.5	29.98	60.3	32.49	64.1	34.84	65.0	35.62	66.2	35.91	
45	40.7	20.49	48.6	25.84	56.5	31.20	60.3	33.58	64.1	35.80	64.6	35.99	65.2	36.39	
48	40.7	21.63	48.6	27.03	56.5	32.38	60.3	34.00	64.1	36.11	64.1	36.50	63.4	36.88	
80%	-5	36.1	7.79	43.1	9.21	50.0	10.91	53.6	11.60	57.2	12.49	64.1	14.44	71.1	16.48
	-2	36.1	7.91	43.1	9.33	50.0	11.00	53.6	11.78	57.2	12.61	64.1	14.58	71.1	16.64
	0	36.1	8.04	43.1	9.44	50.0	11.14	53.6	11.92	57.2	12.83	64.1	14.78	71.1	16.87
	2	36.1	8.21	43.1	9.58	50.0	11.30	53.6	12.15	57.2	13.06	64.1	15.08	71.1	17.19
	4	36.1	8.34	43.1	9.74	50.0	11.51	53.6	12.42	57.2	13.29	64.1	15.36	71.1	17.42
	6	36.1	8.48	43.1	9.97	50.0	11.69	53.6	12.70	57.2	13.55	64.1	15.59	71.1	17.72
	8	36.1	8.64	43.1	10.20	50.0	11.96	53.6	12.90	57.2	13.84	64.1	15.81	71.1	18.06
	10	36.1	8.71	43.1	10.43	50.0	12.28	53.6	13.22	57.2	14.16	64.1	16.18	71.1	18.24
	12	36.1	8.84	43.1	10.60	50.0	12.49	53.6	13.48	57.2	14.46	64.1	16.48	71.1	18.59
	14	36.1	9.01	43.1	10.82	50.0	12.70	53.6	13.69	57.2	14.72	64.1	16.78	71.1	18.93
	16	36.1	9.14	43.1	10.99	50.0	12.96	53.6	13.95	57.2	14.98	64.1	17.13	71.1	19.27
	18	36.1	9.31	43.1	11.20	50.0	13.22	53.6	14.25	57.2	15.28	64.1	17.47	71.1	19.66
	20	36.1	9.49	43.1	11.42	50.0	13.48	53.6	14.51	57.2	15.58	64.1	18.11	71.1	21.03
	21	36.1	9.57	43.1	11.50	50.0	13.60	53.6	14.68	57.2	15.92	64.1	18.76	71.1	21.80
	23	36.1	9.74	43.1	11.76	50.0	14.25	53.6	15.62	57.2	17.04	64.1	20.09	71.1	23.39
	25	36.1	10.04	43.1	12.49	50.0	15.24	53.6	16.70	57.2	18.20	64.1	21.50	71.1	25.02
	27	36.1	10.69	43.1	13.30	50.0	16.22	53.6	17.81	57.2	19.44	64.1	22.96	71.1	26.78
	29	36.1	11.37	43.1	14.16	50.0	17.30	53.6	18.97	57.2	20.77	64.1	24.51	71.1	28.63
	31	36.1	12.06	43.1	15.06	50.0	18.41	53.6	20.21	57.2	22.15	64.1	26.18	69.9	29.74
	33	36.1	12.83	43.1	16.01	50.0	19.61	53.6	21.55	57.2	23.56	64.1	27.90	68.9	30.86
35	36.1	13.60	43.1	17.04	50.0	20.86	53.6	22.92	57.2	25.11	64.1	29.74	67.7	31.97	
37	36.1	14.42	43.1	18.07	50.0	22.19	53.6	24.42	57.2	26.74	64.1	31.72	66.8	33.09	
39	36.1	15.28	43.1	19.27	50.0	23.61	53.6	25.97	57.2	28.46	64.1	33.78	65.6	34.25	
41	36.1	15.62	43.1	19.44	50.0	23.95	53.6	26.66	57.2	28.97	64.1	34.64	65.2	34.85	
43	36.1	16.08	43.1	19.61	50.0	24.29	53.6	27.11	57.2	29.37	64.1	35.04	64.8	35.23	
45	36.1	16.54	43.1	19.84	50.0	24.76	53.6	27.69	57.2	29.88	64.1	35.42	64.0	35.80	
48	36.1	17.07	43.1	19.96	50.0	25.14	53.6	28.05	57.2	30.12	64.1	35.75	63.4	36.26	

Abbreviations:
 CR: Combination ratio
 TC: Total capacity (kW)
 PI: Power input (compressor + outdoor fan motor) (kW)

Notes:
 Shaded cells indicate rating condition.

Table continued on next page ...

Table 2-8.9: 24HP cooling capacity (continued)

Combination (%) (Capacity index)	Outdoor temperature (°C DB)	Indoor temperature(°C DB/WB)													
		DB:20.8,WB:14		DB:23.3,WB:16		DB:25.8,WB:18		DB:27,WB:19		DB:28.2,WB:20		DB:30.7,WB:22		DB:32,WB:24	
		TC	PI	TC	PI	TC	PI	TC	PI	TC	PI	TC	PI	TC	PI
70%	-5	31.6	6.96	37.8	8.16	43.8	9.24	46.9	9.91	50.0	10.58	56.0	12.10	62.2	13.91
	-2	31.6	7.01	37.8	8.19	43.8	9.30	46.9	10.10	50.0	10.77	56.0	12.29	62.2	14.10
	0	31.6	7.05	37.8	8.31	43.8	9.49	46.9	10.29	50.0	10.96	56.0	12.54	62.2	14.29
	2	31.6	7.09	37.8	8.35	43.8	9.64	46.9	10.48	50.0	11.15	56.0	12.81	62.2	14.52
	4	31.6	7.18	37.8	8.56	43.8	9.86	46.9	10.67	50.0	11.40	56.0	13.02	62.2	14.86
	6	31.6	7.30	37.8	8.70	43.8	10.10	46.9	11.01	50.0	11.66	56.0	13.24	62.2	15.15
	8	31.6	7.43	37.8	8.96	43.8	10.33	46.9	11.19	50.0	11.91	56.0	13.63	62.2	15.44
	10	31.6	7.58	37.8	9.10	43.8	10.60	46.9	11.42	50.0	12.23	56.0	13.91	62.2	15.62
	12	31.6	7.77	37.8	9.23	43.8	10.82	46.9	11.63	50.0	12.45	56.0	14.16	62.2	15.92
	14	31.6	7.90	37.8	9.40	43.8	10.99	46.9	11.80	50.0	12.66	56.0	14.42	62.2	16.22
	16	31.6	8.03	37.8	9.57	43.8	11.20	46.9	12.06	50.0	12.92	56.0	14.68	62.2	16.52
	18	31.6	8.15	37.8	9.74	43.8	11.42	46.9	12.27	50.0	13.13	56.0	14.98	62.2	16.87
	20	31.6	8.28	37.8	9.92	43.8	11.63	46.9	12.49	50.0	13.39	56.0	15.28	62.2	17.34
	21	31.6	8.37	37.8	10.00	43.8	11.72	46.9	12.62	50.0	13.52	56.0	15.49	62.2	17.94
	23	31.6	8.50	37.8	10.17	43.8	11.98	46.9	13.05	50.0	14.21	56.0	16.61	62.2	19.23
	25	31.6	8.67	37.8	10.60	43.8	12.75	46.9	13.95	50.0	15.15	56.0	17.77	62.2	20.56
	27	31.6	9.19	37.8	11.29	43.8	13.61	46.9	14.85	50.0	16.18	56.0	18.97	62.2	21.98
	29	31.6	9.74	37.8	11.98	43.8	14.46	46.9	15.84	50.0	17.21	56.0	20.22	62.2	23.48
	31	31.6	10.30	37.8	12.70	43.8	15.41	46.9	16.82	50.0	18.33	56.0	21.55	62.2	25.02
	33	31.6	10.94	37.8	13.52	43.8	16.40	46.9	17.90	50.0	19.53	56.0	22.96	62.2	26.70
35	31.6	11.59	37.8	14.34	43.8	17.38	46.9	19.06	50.0	20.77	56.0	24.46	62.2	28.46	
37	31.6	12.23	37.8	15.19	43.8	18.50	46.9	20.22	50.0	22.10	56.0	26.05	62.2	30.30	
39	31.6	12.96	37.8	16.10	43.8	19.61	46.9	21.50	50.0	23.48	56.0	27.68	62.2	32.28	
41	31.6	13.53	37.8	16.67	43.8	20.19	46.9	22.22	50.0	24.19	56.0	28.83	62.2	33.71	
43	31.6	14.64	37.8	17.81	43.8	21.02	46.9	23.41	50.0	24.91	56.0	29.87	62.2	34.75	
45	31.6	14.96	37.8	18.19	43.8	21.46	46.9	23.79	50.0	26.15	56.0	31.49	62.2	36.09	
48	31.6	15.25	37.8	18.29	43.8	21.72	46.9	24.20	50.0	26.87	56.0	32.97	62.2	36.97	
60%	-5	27.0	5.93	32.3	6.88	37.6	8.02	40.2	8.54	42.8	9.23	48.1	10.36	53.4	11.88
	-2	27.0	5.97	32.3	6.99	37.6	8.17	40.2	8.67	42.8	9.32	48.1	10.52	53.4	11.96
	0	27.0	6.06	32.3	7.08	37.6	8.27	40.2	8.78	42.8	9.48	48.1	10.67	53.4	12.12
	2	27.0	6.17	32.3	7.24	37.6	8.43	40.2	8.95	42.8	9.60	48.1	10.89	53.4	12.27
	4	27.0	6.34	32.3	7.38	37.6	8.59	40.2	9.06	42.8	9.74	48.1	11.06	53.4	12.44
	6	27.0	6.40	32.3	7.52	37.6	8.76	40.2	9.26	42.8	9.94	48.1	11.28	53.4	12.74
	8	27.0	6.52	32.3	7.64	37.6	8.92	40.2	9.43	42.8	10.14	48.1	11.50	53.4	12.94
	10	27.0	6.65	32.3	7.81	37.6	9.05	40.2	9.70	42.8	10.34	48.1	11.71	53.4	13.13
	12	27.0	6.78	32.3	7.94	37.6	9.23	40.2	9.87	42.8	10.51	48.1	11.93	53.4	13.35
	14	27.0	6.87	32.3	8.07	37.6	9.35	40.2	10.04	42.8	10.73	48.1	12.14	53.4	13.60
	16	27.0	6.95	32.3	8.20	37.6	9.53	40.2	10.21	42.8	10.90	48.1	12.36	53.4	13.86
	18	27.0	7.08	32.3	8.32	37.6	9.70	40.2	10.38	42.8	11.11	48.1	12.57	53.4	14.12
	20	27.0	7.17	32.3	8.50	37.6	9.87	40.2	10.60	42.8	11.33	48.1	12.83	53.4	14.42
	21	27.0	7.25	32.3	8.54	37.6	9.96	40.2	10.68	42.8	11.41	48.1	12.96	53.4	14.55
	23	27.0	7.34	32.3	8.71	37.6	10.13	40.2	10.90	42.8	11.63	48.1	13.47	53.4	15.49
	25	27.0	7.47	32.3	8.84	37.6	10.51	40.2	11.41	42.8	12.36	48.1	14.38	53.4	16.52
	27	27.0	7.77	32.3	9.40	37.6	11.20	40.2	12.19	42.8	13.17	48.1	15.32	53.4	17.64
	29	27.0	8.20	32.3	9.96	37.6	11.93	40.2	12.96	42.8	14.03	48.1	16.35	53.4	18.84
	31	27.0	8.71	32.3	10.56	37.6	12.66	40.2	13.77	42.8	14.93	48.1	17.38	53.4	20.04
	33	27.0	9.18	32.3	11.20	37.6	13.43	40.2	14.63	42.8	15.88	48.1	18.50	53.4	21.37
35	27.0	9.74	32.3	11.89	37.6	14.25	40.2	15.53	42.8	16.86	48.1	19.70	53.4	22.74	
37	27.0	10.30	32.3	12.57	37.6	15.11	40.2	16.48	42.8	17.89	48.1	20.94	53.4	24.20	
39	27.0	10.86	32.3	13.30	37.6	16.01	40.2	17.47	42.8	19.01	48.1	22.23	53.4	25.75	
41	27.0	11.21	32.3	13.88	37.6	16.59	40.2	18.16	42.8	19.71	48.1	23.28	53.4	26.91	
43	27.0	11.56	32.3	14.46	37.6	17.17	40.2	18.71	42.8	20.40	48.1	24.26	53.4	28.08	
45	27.0	12.10	32.3	15.20	37.6	17.87	40.2	19.41	42.8	21.41	48.1	25.35	53.4	29.63	
48	27.0	12.55	32.3	15.84	37.6	18.49	40.2	19.88	42.8	22.21	48.1	26.25	53.4	31.07	

Abbreviations:

CR: Combination ratio

TC: Total capacity (kW)

PI: Power input (compressor + outdoor fan motor) (kW)

Notes:

Shaded cells indicate rating condition.

Table continued on next page ...

Table 2-8.9: 24HP cooling capacity (continued)

Combination (%) (Capacity index)	Outdoor temperature (°C DB)	Indoor temperature(°C DB/WB)													
		DB:20.8,WB:14		DB:23.3,WB:16		DB:25.8,WB:18		DB:27,WB:19		DB:28.2,WB:20		DB:30.7,WB:22		DB:32,WB:24	
		TC	PI	TC	PI	TC	PI	TC	PI	TC	PI	TC	PI	TC	PI
50%	-5	22.6	5.15	27.0	5.96	31.3	6.85	33.5	7.17	35.7	7.56	40.0	8.60	44.5	9.27
	-2	22.6	5.19	27.0	6.08	31.3	6.92	33.5	7.27	35.7	7.70	40.0	8.71	44.5	9.39
	0	22.6	5.28	27.0	6.18	31.3	7.04	33.5	7.37	35.7	7.79	40.0	8.86	44.5	9.55
	2	22.6	5.35	27.0	6.26	31.3	7.17	33.5	7.48	35.7	7.92	40.0	8.90	44.5	9.74
	4	22.6	5.40	27.0	6.37	31.3	7.24	33.5	7.56	35.7	8.08	40.0	9.12	44.5	9.99
	6	22.6	5.50	27.0	6.46	31.3	7.35	33.5	7.74	35.7	8.23	40.0	9.26	44.5	10.28
	8	22.6	5.64	27.0	6.58	31.3	7.48	33.5	7.91	35.7	8.34	40.0	9.41	44.5	10.61
	10	22.6	5.75	27.0	6.65	31.3	7.60	33.5	8.03	35.7	8.58	40.0	9.66	44.5	10.77
	12	22.6	5.79	27.0	6.74	31.3	7.72	33.5	8.20	35.7	8.75	40.0	9.83	44.5	10.94
	14	22.6	5.88	27.0	6.82	31.3	7.81	33.5	8.37	35.7	8.88	40.0	10.00	44.5	11.16
	16	22.6	5.96	27.0	6.91	31.3	7.94	33.5	8.50	35.7	9.01	40.0	10.17	44.5	11.33
	18	22.6	6.05	27.0	7.04	31.3	8.07	33.5	8.63	35.7	9.18	40.0	10.34	44.5	11.54
	20	22.6	6.14	27.0	7.12	31.3	8.20	33.5	8.75	35.7	9.35	40.0	10.51	44.5	11.76
	21	22.6	6.18	27.0	7.21	31.3	8.28	33.5	8.84	35.7	9.44	40.0	10.64	44.5	11.89
	23	22.6	6.26	27.0	7.30	31.3	8.41	33.5	9.01	35.7	9.61	40.0	10.81	44.5	12.14
	25	22.6	6.35	27.0	7.42	31.3	8.58	33.5	9.18	35.7	9.91	40.0	11.37	44.5	12.96
	27	22.6	6.48	27.0	7.72	31.3	9.05	33.5	9.78	35.7	10.51	40.0	12.10	44.5	13.82
	29	22.6	6.82	27.0	8.15	31.3	9.61	33.5	10.39	35.7	11.20	40.0	12.87	44.5	14.72
	31	22.6	7.21	27.0	8.63	31.3	10.17	33.5	11.03	35.7	11.89	40.0	13.69	44.5	15.66
	33	22.6	7.64	27.0	9.14	31.3	10.81	33.5	11.67	35.7	12.62	40.0	14.55	44.5	16.65
35	22.6	8.07	27.0	9.66	31.3	11.42	33.5	12.36	35.7	13.35	40.0	15.45	44.5	17.68	
37	22.6	8.50	27.0	10.21	31.3	12.10	33.5	13.09	35.7	14.16	40.0	16.39	44.5	18.80	
39	22.6	8.97	27.0	10.77	31.3	12.79	33.5	13.86	35.7	15.02	40.0	17.38	44.5	19.96	
41	22.6	9.34	27.0	11.23	31.3	13.25	33.5	14.51	35.7	15.67	40.0	18.31	44.5	20.88	
43	22.6	9.96	27.0	12.01	31.3	13.72	33.5	15.16	35.7	16.07	40.0	19.23	44.5	21.81	
45	22.6	10.19	27.0	12.32	31.3	14.64	33.5	16.33	35.7	16.75	40.0	21.09	44.5	23.66	
48	22.6	10.38	27.0	12.61	31.3	15.45	33.5	17.43	35.7	17.55	40.0	22.74	44.5	25.46	

Abbreviations:

CR: Combination ratio

TC: Total capacity (kW)

PI: Power input (compressor + outdoor fan motor) (kW)

Notes:

Shaded cells indicate rating condition.

Table 2-8.10: 26HP cooling capacity

Combination (%) (Capacity index)	Outdoor temperature (°C DB)	Indoor temperature(°C DB/WB)													
		DB:20.8,WB:14		DB:23.3,WB:16		DB:25.8,WB:18		DB:27,WB:19		DB:28.2,WB:20		DB:30.7,WB:22		DB:32,WB:24	
		TC kW	PI kW	TC kW	PI kW	TC kW	PI kW	TC kW	PI kW	TC kW	PI kW	TC kW	PI kW	TC kW	PI kW
130%	-5	64.1	14.01	76.4	17.10	88.6	18.33	92.0	19.08	96.5	19.62	98.8	21.33	101.3	21.47
	-2	64.1	14.01	76.4	17.43	88.6	18.33	92.0	19.19	96.5	19.62	98.8	21.60	101.3	21.68
	0	64.1	14.25	76.4	17.73	88.6	19.00	92.0	20.24	96.5	20.76	98.8	21.87	101.3	21.97
	2	64.1	14.51	76.4	17.77	88.6	19.65	92.0	21.38	96.5	21.00	98.8	22.03	101.3	22.30
	4	64.1	14.83	76.4	18.12	88.6	20.33	92.0	21.47	96.5	21.27	98.8	22.36	101.3	22.72
	6	64.1	15.12	76.4	18.48	88.6	21.08	92.0	21.65	95.4	21.93	97.6	22.71	100.2	22.89
	8	64.1	15.48	76.4	18.90	88.6	22.14	92.0	22.71	94.2	22.65	96.5	22.78	98.9	23.11
	10	64.1	15.80	76.4	19.31	88.6	22.96	92.0	23.47	93.1	23.07	95.4	23.13	97.8	23.78
	12	64.1	16.08	76.4	19.68	88.6	23.42	90.7	23.82	92.0	23.42	94.1	23.48	96.5	23.93
	14	64.1	16.40	76.4	20.05	88.4	23.77	89.7	24.17	90.7	23.77	93.1	23.83	95.4	24.47
	16	64.1	16.68	76.4	20.46	87.3	24.12	88.4	24.48	89.4	24.47	91.8	24.18	94.1	24.86
	18	64.1	17.00	76.4	20.88	86.0	24.48	87.1	24.62	88.4	24.76	90.7	24.99	93.1	25.22
	20	64.1	17.37	76.4	22.22	84.7	25.69	86.0	25.82	87.1	25.96	89.4	26.19	91.8	26.47
	21	64.1	17.83	76.4	23.01	84.2	26.29	85.5	26.42	86.6	26.56	88.9	26.84	91.2	27.07
	23	64.1	19.13	76.4	24.67	83.2	27.49	84.2	27.62	85.2	27.76	87.6	28.04	89.9	28.32
	25	64.1	20.42	76.4	26.42	81.9	28.69	82.9	28.83	84.2	29.01	86.6	29.29	88.9	29.56
	27	64.1	21.80	76.4	28.27	80.8	29.89	81.9	30.07	82.9	30.21	85.2	30.54	87.6	30.86
	29	64.1	23.28	76.4	30.21	79.5	31.09	80.6	31.27	81.9	31.46	84.2	31.78	86.6	32.11
	31	64.1	24.85	76.1	31.97	78.2	32.34	79.5	32.52	80.6	32.66	82.9	33.03	85.2	33.40
	33	64.1	26.47	74.8	33.17	77.2	33.54	78.2	33.72	79.5	33.91	81.9	34.28	83.9	34.65
35	64.1	28.22	73.5	34.37	75.9	34.79	77.2	34.97	78.2	35.16	80.6	35.57	82.9	35.94	
37	64.1	30.03	72.5	35.62	74.8	36.03	75.9	36.22	77.2	36.45	79.3	36.87	81.6	37.28	
39	64.1	31.97	71.2	35.99	73.5	37.23	74.8	37.46	75.9	37.70	78.2	38.11	80.6	38.57	
41	64.1	33.65	70.4	36.34	72.7	37.58	74.1	37.81	75.1	38.04	77.4	38.19	77.5	38.92	
43	64.1	34.50	69.9	36.51	72.4	37.69	73.7	37.99	74.3	38.10	76.0	38.26	76.5	39.01	
45	64.1	36.21	69.5	36.86	71.6	38.04	72.9	38.23	73.2	38.27	74.0	38.40	75.0	39.74	
48	64.1	37.46	69.3	38.04	70.4	38.36	71.7	38.55	72.3	38.68	72.0	39.06	73.3	39.89	
120%	-5	59.2	13.53	70.4	16.39	81.9	19.38	87.6	21.14	91.8	22.03	93.9	22.74	95.9	23.34
	-2	59.2	13.67	70.4	16.56	81.9	19.57	87.6	21.26	91.8	22.29	93.9	22.93	95.9	23.42
	0	59.2	13.79	70.4	16.67	81.9	19.80	87.6	21.31	91.8	22.49	93.9	23.07	95.9	23.47
	2	59.2	13.83	70.4	16.85	81.9	19.94	87.6	21.52	91.8	22.58	93.9	23.24	95.9	23.52
	4	59.2	13.96	70.4	17.06	81.9	20.22	87.6	21.71	91.8	22.88	93.9	23.28	95.9	23.58
	6	59.2	14.11	70.4	17.20	81.9	20.46	87.6	21.95	91.8	23.13	93.9	23.48	95.9	23.66
	8	59.2	14.24	70.4	17.37	81.9	20.74	87.6	22.23	91.8	23.36	93.9	23.55	95.9	23.77
	10	59.2	14.41	70.4	17.60	81.9	20.93	87.6	22.64	91.8	23.38	93.9	23.62	95.9	23.88
	12	59.2	14.69	70.4	17.92	81.9	21.34	87.6	23.05	90.5	23.48	92.5	23.49	94.6	24.03
	14	59.2	14.97	70.4	18.29	81.9	21.76	87.6	23.51	89.2	23.62	91.5	23.85	93.6	24.32
	16	59.2	15.24	70.4	18.66	81.9	22.17	87.1	23.93	88.1	23.97	90.2	24.25	92.3	24.68
	18	59.2	15.52	70.4	19.03	81.9	22.91	85.8	24.48	86.8	24.57	88.9	24.81	91.2	25.04
	20	59.2	15.84	70.4	19.77	81.9	24.67	84.7	25.69	85.8	25.78	87.9	26.01	89.9	26.24
	21	59.2	15.98	70.4	20.46	81.9	25.55	83.9	26.28	85.0	26.38	87.3	26.61	89.4	26.88
	23	59.2	17.09	70.4	21.94	81.9	27.35	82.9	27.44	83.9	27.58	86.0	27.86	88.1	28.09
	25	59.2	18.25	70.4	23.47	80.6	28.55	81.6	28.64	82.6	28.78	85.0	29.05	87.1	29.33
	27	59.2	19.49	70.4	25.08	79.5	29.70	80.6	29.89	81.6	30.03	83.7	30.30	85.8	30.58
	29	59.2	20.79	70.4	26.79	78.2	30.90	79.3	31.09	80.3	31.23	82.4	31.55	84.7	31.83
	31	59.2	22.17	70.4	28.59	76.9	32.15	78.2	32.29	79.3	32.47	81.3	32.80	83.4	33.12
	33	59.2	23.60	70.4	30.49	75.9	33.35	76.9	33.54	77.9	33.67	80.0	34.05	82.1	34.37
35	59.2	25.13	70.4	32.52	74.6	34.55	75.6	34.74	76.9	34.92	79.0	35.29	81.1	35.66	
37	59.2	26.74	70.4	34.64	73.5	35.80	74.6	35.98	75.6	36.17	77.7	36.54	79.8	36.95	
39	59.2	28.45	70.1	36.59	72.2	37.00	73.3	37.23	74.3	37.42	76.6	37.83	78.7	38.20	
41	59.2	29.24	69.6	36.85	71.7	37.26	72.7	37.49	73.7	37.68	76.1	37.94	76.5	38.49	
43	59.2	29.67	69.2	37.11	71.1	37.49	72.1	37.63	73.2	37.81	74.8	38.04	75.3	39.26	
45	59.2	30.02	68.8	37.45	70.4	37.84	71.4	37.99	72.5	38.11	73.2	38.16	74.5	40.11	
48	59.2	30.22	68.2	37.86	69.5	38.17	70.2	38.21	71.7	38.45	72.1	38.56	73.5	40.61	

Abbreviations:

CR: Combination ratio

TC: Total capacity (kW)

PI: Power input (compressor + outdoor fan motor) (kW)

Notes:

Shaded cells indicate rating condition.

Table continued on next page ...

Table 2-8.10: 26HP cooling capacity (continued)

Combination (%) (Capacity index)	Outdoor temperature (°C DB)	Indoor temperature(°C DB/WB)													
		DB:20.8,WB:14		DB:23.3,WB:16		DB:25.8,WB:18		DB:27,WB:19		DB:28.2,WB:20		DB:30.7,WB:22		DB:32,WB:24	
		TC kW	PI kW	TC kW	PI kW	TC kW	PI kW	TC kW	PI kW	TC kW	PI kW	TC kW	PI kW	TC kW	PI kW
110%	-5	54.2	11.82	64.7	14.71	75.1	17.55	80.3	18.84	85.5	20.27	92.0	21.06	94.1	21.71
	-2	54.2	12.04	64.7	14.90	75.1	17.70	80.3	19.03	85.5	20.43	92.0	21.26	94.1	21.82
	0	54.2	12.16	64.7	14.99	75.1	17.84	80.3	19.15	85.5	20.66	92.0	21.47	94.1	22.09
	2	54.2	12.43	64.7	15.13	75.1	18.12	80.3	19.36	85.5	20.88	92.0	21.78	94.1	22.36
	4	54.2	12.68	64.7	15.30	75.1	18.29	80.3	19.60	85.5	21.20	92.0	22.09	94.1	22.57
	6	54.2	12.80	64.7	15.48	75.1	18.47	80.3	19.91	85.5	21.44	92.0	22.32	94.1	22.91
	8	54.2	12.92	64.7	15.72	75.1	18.68	80.3	20.12	85.5	21.68	92.0	22.47	94.1	23.15
	10	54.2	13.07	64.7	15.94	75.1	18.94	80.3	20.46	85.5	22.04	92.0	22.63	94.1	23.36
	12	54.2	13.35	64.7	16.26	75.1	19.31	80.3	20.88	85.5	22.45	91.0	22.96	92.8	23.66
	14	54.2	13.58	64.7	16.54	75.1	19.68	80.3	21.25	85.5	22.87	89.7	23.14	91.8	23.83
	16	54.2	13.81	64.7	16.86	75.1	20.05	80.3	21.66	85.5	23.33	88.6	23.42	90.5	24.09
	18	54.2	14.09	64.7	17.19	75.1	20.46	80.3	22.26	85.5	24.44	87.3	24.62	89.4	24.85
	20	54.2	14.37	64.7	17.55	75.1	21.66	80.3	23.93	84.2	25.64	86.3	25.82	88.1	26.05
	21	54.2	14.50	64.7	18.06	75.1	22.45	80.3	24.81	83.7	26.24	85.5	26.42	87.6	26.65
	23	54.2	15.20	64.7	19.36	75.1	24.07	80.3	26.61	82.4	27.39	84.5	27.67	86.3	27.90
	25	54.2	16.22	64.7	20.69	75.1	25.73	80.3	28.50	81.3	28.59	83.2	28.87	85.3	29.10
	27	54.2	17.28	64.7	22.13	75.1	27.53	79.0	29.70	80.0	29.80	82.1	30.07	84.0	30.35
	29	54.2	18.43	64.7	23.61	75.1	29.43	78.0	30.91	79.0	31.04	80.8	31.32	82.9	31.60
	31	54.2	19.63	64.7	25.18	75.1	31.41	76.7	32.11	77.7	32.24	79.8	32.52	81.6	32.84
	33	54.2	20.88	64.7	26.84	74.6	33.12	75.6	33.31	76.7	33.45	78.5	33.77	80.6	34.09
35	54.2	22.22	64.7	28.59	73.3	34.32	74.3	34.51	75.3	34.69	77.2	35.02	79.3	35.34	
37	54.2	23.65	64.7	30.44	72.2	35.57	73.3	35.71	74.0	35.90	76.1	36.26	78.0	36.59	
39	54.2	25.13	64.7	32.43	70.9	36.77	72.0	36.96	73.0	37.14	74.8	37.51	76.9	37.88	
41	54.2	25.39	64.7	32.69	70.4	37.03	71.4	37.22	72.4	37.40	73.9	37.77	74.6	38.14	
43	54.2	25.65	64.7	33.11	69.8	37.29	70.8	37.48	71.9	37.66	73.2	37.91	73.5	38.91	
45	54.2	26.48	64.7	33.29	69.1	37.63	70.1	37.93	71.3	38.00	72.5	38.94	72.8	39.82	
48	54.2	27.35	64.7	36.04	68.1	37.81	69.0	38.11	70.4	38.34	71.3	39.00	71.8	40.16	
100%	-5	49.3	10.76	58.7	12.96	68.3	15.42	73.0	16.52	77.7	17.93	87.3	20.43	92.3	21.32
	-2	49.3	10.89	58.7	13.13	68.3	15.60	73.0	16.83	77.7	18.17	87.3	20.67	92.3	21.46
	0	49.3	11.00	58.7	13.26	68.3	15.77	73.0	17.03	77.7	18.34	87.3	21.01	92.3	21.70
	2	49.3	11.22	58.7	13.45	68.3	15.94	73.0	17.26	77.7	18.54	87.3	21.32	92.3	22.04
	4	49.3	11.30	58.7	13.57	68.3	16.18	73.0	17.51	77.7	18.78	87.3	21.52	92.3	22.28
	6	49.3	11.46	58.7	13.85	68.3	16.38	73.0	17.82	77.7	19.06	87.3	21.83	92.3	22.62
	8	49.3	11.69	58.7	14.05	68.3	16.69	73.0	18.03	77.7	19.37	87.3	22.18	92.3	23.00
	10	49.3	11.82	58.7	14.32	68.3	16.95	73.0	18.34	77.7	19.73	87.3	22.54	92.3	23.33
	12	49.3	12.01	58.7	14.60	68.3	17.27	73.0	18.66	77.7	20.10	87.3	22.96	91.0	23.51
	14	49.3	12.24	58.7	14.88	68.3	17.60	73.0	19.03	77.7	20.46	87.3	23.42	89.9	23.79
	16	49.3	12.47	58.7	15.15	68.3	17.97	73.0	19.40	77.7	20.88	86.8	23.70	88.6	24.07
	18	49.3	12.70	58.7	15.43	68.3	18.29	73.0	19.77	77.7	21.30	85.8	24.48	87.6	24.67
	20	49.3	12.94	58.7	15.75	68.3	18.85	73.0	20.78	77.7	22.82	84.5	25.64	86.3	25.87
	21	49.3	13.07	58.7	15.89	68.3	19.54	73.0	21.52	77.7	23.61	84.0	26.24	85.8	26.47
	23	49.3	13.39	58.7	16.95	68.3	20.92	73.0	23.05	77.7	25.31	82.9	27.44	84.5	27.67
	25	49.3	14.27	58.7	18.11	68.3	22.40	73.0	24.71	77.7	27.11	81.6	28.64	83.4	28.87
	27	49.3	15.24	58.7	19.31	68.3	23.93	73.0	26.42	77.7	29.01	80.3	29.84	82.1	30.12
	29	49.3	16.21	58.7	20.60	68.3	25.55	73.0	28.23	77.4	30.81	79.3	31.09	81.1	31.32
	31	49.3	17.27	58.7	21.99	68.3	27.25	73.0	30.12	76.4	32.01	78.0	32.29	79.8	32.56
	33	49.3	18.34	58.7	23.42	68.3	29.05	73.0	32.15	75.1	33.21	76.9	33.49	78.7	33.81
35	49.3	19.49	58.7	24.90	68.3	30.99	73.0	34.28	73.8	34.41	75.6	34.73	77.4	35.02	
37	49.3	20.74	58.7	26.52	68.3	33.03	71.7	35.47	72.7	35.66	74.6	35.98	76.1	36.26	
39	49.3	22.03	58.7	28.18	68.3	35.15	70.6	36.68	71.4	36.86	73.3	37.18	75.1	37.56	
41	49.3	23.06	58.7	29.21	68.3	36.44	69.6	36.93	70.9	37.43	72.0	38.06	74.0	38.33	
43	49.3	24.09	58.7	30.23	68.3	37.11	68.5	37.36	70.4	37.79	72.4	38.31	72.7	38.75	
45	49.3	25.46	58.7	31.60	68.3	37.75	67.0	37.88	70.0	38.48	71.8	38.90	71.2	39.27	
48	49.3	26.58	58.7	32.71	68.3	37.81	64.2	38.31	69.9	39.16	67.4	39.30	69.7	39.64	

Abbreviations:

CR: Combination ratio

TC: Total capacity (kW)

PI: Power input (compressor + outdoor fan motor) (kW)

Notes:

Shaded cells indicate rating condition.

Table continued on next page ...

Table 2-8.10: 26HP cooling capacity (continued)

Combination (%) (Capacity index)	Outdoor temperature (°C DB)	Indoor temperature(°C DB/WB)													
		DB:20.8,WB:14		DB:23.3,WB:16		DB:25.8,WB:18		DB:27,WB:19		DB:28.2,WB:20		DB:30.7,WB:22		DB:32,WB:24	
		TC kW	PI kW	TC kW	PI kW	TC kW	PI kW	TC kW	PI kW	TC kW	PI kW	TC kW	PI kW	TC kW	PI kW
90%	-5	44.3	9.52	52.9	11.42	61.5	13.47	65.7	14.70	69.9	15.64	78.5	17.98	87.1	20.59
	-2	44.3	9.61	52.9	11.54	61.5	13.65	65.7	14.91	69.9	15.83	78.5	18.16	87.1	20.79
	0	44.3	9.75	52.9	11.68	61.5	13.85	65.7	15.08	69.9	16.03	78.5	18.36	87.1	20.95
	2	44.3	9.90	52.9	11.83	61.5	14.00	65.7	15.32	69.9	16.28	78.5	18.74	87.1	21.26
	4	44.3	10.05	52.9	12.01	61.5	14.23	65.7	15.52	69.9	16.49	78.5	19.03	87.1	21.57
	6	44.3	10.19	52.9	12.24	61.5	14.50	65.7	15.81	69.9	16.78	78.5	19.33	87.1	21.93
	8	44.3	10.38	52.9	12.48	61.5	14.79	65.7	16.02	69.9	17.07	78.5	19.69	87.1	22.14
	10	44.3	10.58	52.9	12.75	61.5	15.06	65.7	16.26	69.9	17.46	78.5	19.94	87.1	22.49
	12	44.3	10.76	52.9	12.98	61.5	15.34	65.7	16.53	69.9	17.78	78.5	20.32	87.1	22.91
	14	44.3	10.95	52.9	13.21	61.5	15.61	65.7	16.86	69.9	18.11	78.5	20.69	87.1	23.33
	16	44.3	11.13	52.9	13.44	61.5	15.94	65.7	17.18	69.9	18.48	78.5	21.11	86.8	23.74
	18	44.3	11.32	52.9	13.72	61.5	16.21	65.7	17.51	69.9	18.84	78.5	21.52	85.8	24.48
	20	44.3	11.55	52.9	14.03	61.5	16.54	65.7	17.88	69.9	19.54	78.5	23.14	84.5	25.64
	21	44.3	11.64	52.9	14.13	61.5	16.81	65.7	18.48	69.9	20.23	78.5	23.97	84.0	26.24
	23	44.3	11.87	52.9	14.69	61.5	18.01	65.7	19.82	69.9	21.71	78.5	25.73	82.6	27.44
	25	44.3	12.52	52.9	15.71	61.5	19.26	65.7	21.20	69.9	23.19	78.5	27.53	81.6	28.64
	27	44.3	13.30	52.9	16.72	61.5	20.55	65.7	22.63	69.9	24.80	78.5	29.47	80.3	29.84
	29	44.3	14.18	52.9	17.83	61.5	21.94	65.7	24.16	69.9	26.51	77.7	30.81	79.3	31.04
	31	44.3	15.06	52.9	18.99	61.5	23.37	65.7	25.77	69.9	28.27	76.4	32.01	78.0	32.29
	33	44.3	15.98	52.9	20.19	61.5	24.94	65.7	27.48	69.9	30.16	75.3	33.26	76.9	33.49
35	44.3	17.00	52.9	21.48	61.5	26.56	65.7	29.28	69.9	32.15	74.0	34.46	75.6	34.73	
37	44.3	18.01	52.9	22.82	61.5	28.27	65.7	31.18	69.9	34.27	72.7	35.66	74.6	35.94	
39	44.3	19.12	52.9	24.30	61.5	30.07	65.7	33.21	69.9	36.49	71.7	36.91	73.3	37.18	
41	44.3	19.78	52.9	25.40	61.5	31.17	65.7	34.09	69.9	36.71	71.2	37.85	72.8	38.06	
43	44.3	20.73	52.9	26.49	61.5	32.27	65.7	34.97	69.9	37.49	70.8	38.34	72.1	38.65	
45	44.3	22.05	52.9	27.81	61.5	33.58	65.7	36.14	69.9	38.53	70.4	38.74	71.0	39.17	
48	44.3	23.28	52.9	29.09	61.5	34.85	65.7	36.60	69.9	38.86	69.8	39.28	69.1	39.70	
80%	-5	39.4	8.39	46.9	9.92	54.5	11.74	58.4	12.48	62.3	13.44	69.9	15.54	77.4	17.74
	-2	39.4	8.51	46.9	10.04	54.5	11.84	58.4	12.68	62.3	13.57	69.9	15.69	77.4	17.91
	0	39.4	8.66	46.9	10.16	54.5	11.99	58.4	12.83	62.3	13.81	69.9	15.91	77.4	18.16
	2	39.4	8.83	46.9	10.31	54.5	12.16	58.4	13.07	62.3	14.06	69.9	16.23	77.4	18.50
	4	39.4	8.98	46.9	10.48	54.5	12.39	58.4	13.37	62.3	14.31	69.9	16.53	77.4	18.75
	6	39.4	9.13	46.9	10.73	54.5	12.58	58.4	13.67	62.3	14.58	69.9	16.77	77.4	19.07
	8	39.4	9.30	46.9	10.98	54.5	12.88	58.4	13.89	62.3	14.90	69.9	17.02	77.4	19.44
	10	39.4	9.38	46.9	11.23	54.5	13.21	58.4	14.23	62.3	15.24	69.9	17.42	77.4	19.63
	12	39.4	9.52	46.9	11.41	54.5	13.44	58.4	14.50	62.3	15.57	69.9	17.74	77.4	20.00
	14	39.4	9.70	46.9	11.64	54.5	13.67	58.4	14.74	62.3	15.84	69.9	18.06	77.4	20.37
	16	39.4	9.84	46.9	11.83	54.5	13.95	58.4	15.01	62.3	16.12	69.9	18.43	77.4	20.74
	18	39.4	10.02	46.9	12.06	54.5	14.23	58.4	15.34	62.3	16.45	69.9	18.80	77.4	21.16
	20	39.4	10.21	46.9	12.29	54.5	14.50	58.4	15.61	62.3	16.77	69.9	19.49	77.4	22.64
	21	39.4	10.30	46.9	12.38	54.5	14.64	58.4	15.80	62.3	17.14	69.9	20.19	77.4	23.47
	23	39.4	10.49	46.9	12.66	54.5	15.34	58.4	16.81	62.3	18.34	69.9	21.62	77.4	25.18
	25	39.4	10.81	46.9	13.44	54.5	16.40	58.4	17.97	62.3	19.59	69.9	23.14	77.4	26.93
	27	39.4	11.50	46.9	14.32	54.5	17.46	58.4	19.17	62.3	20.93	69.9	24.71	77.4	28.82
	29	39.4	12.24	46.9	15.24	54.5	18.62	58.4	20.42	62.3	22.36	69.9	26.38	77.4	30.81
	31	39.4	12.98	46.9	16.21	54.5	19.82	58.4	21.76	62.3	23.84	69.9	28.18	76.1	32.01
	33	39.4	13.81	46.9	17.23	54.5	21.11	58.4	23.19	62.3	25.36	69.9	30.03	75.1	33.21
35	39.4	14.64	46.9	18.34	54.5	22.45	58.4	24.67	62.3	27.02	69.9	32.01	73.8	34.41	
37	39.4	15.52	46.9	19.45	54.5	23.88	58.4	26.28	62.3	28.78	69.9	34.14	72.7	35.62	
39	39.4	16.45	46.9	20.74	54.5	25.41	58.4	27.95	62.3	30.63	69.9	36.36	71.4	36.86	
41	39.4	16.82	46.9	20.93	54.5	25.78	58.4	28.69	62.3	31.18	69.9	37.28	71.0	37.51	
43	39.4	17.31	46.9	21.11	54.5	26.15	58.4	29.18	62.3	31.61	69.9	37.71	70.6	37.91	
45	39.4	17.80	46.9	21.36	54.5	26.65	58.4	29.80	62.3	32.16	69.9	38.13	69.7	38.54	
48	39.4	18.38	46.9	21.49	54.5	27.06	58.4	30.19	62.3	32.41	69.9	38.48	69.1	39.02	

Abbreviations:

CR: Combination ratio

TC: Total capacity (kW)

PI: Power input (compressor + outdoor fan motor) (kW)

Notes:

Shaded cells indicate rating condition.

Table continued on next page ...

Table 2-8.10: 26HP cooling capacity (continued)

Combination (%) (Capacity index)	Outdoor temperature (°C DB)	Indoor temperature(°C DB/WB)													
		DB:20.8,WB:14		DB:23.3,WB:16		DB:25.8,WB:18		DB:27,WB:19		DB:28.2,WB:20		DB:30.7,WB:22		DB:32,WB:24	
		TC	PI	TC	PI	TC	PI	TC	PI	TC	PI	TC	PI	TC	PI
70%	-5	34.4	7.49	41.2	8.78	47.7	9.95	51.1	10.67	54.5	11.38	61.0	13.02	67.8	14.97
	-2	34.4	7.55	41.2	8.82	47.7	10.01	51.1	10.87	54.5	11.59	61.0	13.23	67.8	15.18
	0	34.4	7.59	41.2	8.94	47.7	10.21	51.1	11.08	54.5	11.79	61.0	13.50	67.8	15.38
	2	34.4	7.63	41.2	8.98	47.7	10.38	51.1	11.28	54.5	12.00	61.0	13.78	67.8	15.63
	4	34.4	7.73	41.2	9.21	47.7	10.61	51.1	11.49	54.5	12.27	61.0	14.01	67.8	16.00
	6	34.4	7.86	41.2	9.37	47.7	10.87	51.1	11.85	54.5	12.55	61.0	14.25	67.8	16.31
	8	34.4	8.00	41.2	9.64	47.7	11.12	51.1	12.04	54.5	12.82	61.0	14.66	67.8	16.61
	10	34.4	8.16	41.2	9.79	47.7	11.41	51.1	12.29	54.5	13.17	61.0	14.97	67.8	16.81
	12	34.4	8.36	41.2	9.93	47.7	11.64	51.1	12.52	54.5	13.40	61.0	15.24	67.8	17.14
	14	34.4	8.50	41.2	10.12	47.7	11.83	51.1	12.70	54.5	13.63	61.0	15.52	67.8	17.46
	16	34.4	8.64	41.2	10.30	47.7	12.06	51.1	12.98	54.5	13.90	61.0	15.80	67.8	17.78
	18	34.4	8.78	41.2	10.49	47.7	12.29	51.1	13.21	54.5	14.14	61.0	16.12	67.8	18.15
	20	34.4	8.92	41.2	10.67	47.7	12.52	51.1	13.44	54.5	14.41	61.0	16.45	67.8	18.66
	21	34.4	9.01	41.2	10.76	47.7	12.61	51.1	13.58	54.5	14.55	61.0	16.68	67.8	19.31
	23	34.4	9.15	41.2	10.95	47.7	12.89	51.1	14.04	54.5	15.29	61.0	17.88	67.8	20.69
	25	34.4	9.33	41.2	11.41	47.7	13.72	51.1	15.01	54.5	16.31	61.0	19.12	67.8	22.13
	27	34.4	9.89	41.2	12.15	47.7	14.64	51.1	15.98	54.5	17.42	61.0	20.42	67.8	23.65
	29	34.4	10.49	41.2	12.89	47.7	15.57	51.1	17.05	54.5	18.52	61.0	21.76	67.8	25.27
	31	34.4	11.09	41.2	13.67	47.7	16.58	51.1	18.11	54.5	19.72	61.0	23.19	67.8	26.93
	33	34.4	11.78	41.2	14.55	47.7	17.65	51.1	19.26	54.5	21.02	61.0	24.71	67.8	28.73
35	34.4	12.47	41.2	15.43	47.7	18.71	51.1	20.51	54.5	22.36	61.0	26.33	67.8	30.63	
37	34.4	13.17	41.2	16.35	47.7	19.91	51.1	21.76	54.5	23.79	61.0	28.04	67.8	32.61	
39	34.4	13.95	41.2	17.32	47.7	21.11	51.1	23.14	54.5	25.27	61.0	29.80	67.8	34.74	
41	34.4	14.57	41.2	17.94	47.7	21.73	51.1	23.91	54.5	26.04	61.0	31.03	67.8	36.28	
43	34.4	15.75	41.2	19.17	47.7	22.62	51.1	25.19	54.5	26.81	61.0	32.15	67.8	37.40	
45	34.4	16.10	41.2	19.58	47.7	23.10	51.1	25.60	54.5	28.14	61.0	33.90	67.8	38.84	
48	34.4	16.41	41.2	19.69	47.7	23.38	51.1	26.05	54.5	28.92	61.0	35.48	67.8	39.79	
60%	-5	29.5	6.39	35.2	7.41	40.9	8.63	43.8	9.20	46.7	9.93	52.4	11.15	58.1	12.79
	-2	29.5	6.42	35.2	7.52	40.9	8.79	43.8	9.33	46.7	10.03	52.4	11.32	58.1	12.87
	0	29.5	6.52	35.2	7.62	40.9	8.90	43.8	9.45	46.7	10.20	52.4	11.49	58.1	13.04
	2	29.5	6.64	35.2	7.79	40.9	9.07	43.8	9.63	46.7	10.34	52.4	11.72	58.1	13.21
	4	29.5	6.82	35.2	7.94	40.9	9.25	43.8	9.75	46.7	10.49	52.4	11.90	58.1	13.39
	6	29.5	6.89	35.2	8.09	40.9	9.42	43.8	9.96	46.7	10.70	52.4	12.14	58.1	13.71
	8	29.5	7.02	35.2	8.23	40.9	9.60	43.8	10.15	46.7	10.92	52.4	12.37	58.1	13.93
	10	29.5	7.16	35.2	8.41	40.9	9.75	43.8	10.44	46.7	11.13	52.4	12.61	58.1	14.13
	12	29.5	7.30	35.2	8.54	40.9	9.93	43.8	10.62	46.7	11.32	52.4	12.84	58.1	14.36
	14	29.5	7.39	35.2	8.68	40.9	10.07	43.8	10.81	46.7	11.55	52.4	13.07	58.1	14.64
	16	29.5	7.48	35.2	8.82	40.9	10.25	43.8	10.99	46.7	11.73	52.4	13.30	58.1	14.92
	18	29.5	7.62	35.2	8.96	40.9	10.44	43.8	11.18	46.7	11.96	52.4	13.53	58.1	15.19
	20	29.5	7.71	35.2	9.15	40.9	10.62	43.8	11.41	46.7	12.19	52.4	13.81	58.1	15.52
	21	29.5	7.81	35.2	9.19	40.9	10.72	43.8	11.50	46.7	12.29	52.4	13.95	58.1	15.66
	23	29.5	7.90	35.2	9.38	40.9	10.90	43.8	11.73	46.7	12.52	52.4	14.50	58.1	16.67
	25	29.5	8.04	35.2	9.51	40.9	11.32	43.8	12.29	46.7	13.30	52.4	15.47	58.1	17.78
	27	29.5	8.36	35.2	10.12	40.9	12.05	43.8	13.12	46.7	14.18	52.4	16.49	58.1	18.98
	29	29.5	8.82	35.2	10.72	40.9	12.84	43.8	13.95	46.7	15.10	52.4	17.60	58.1	20.28
	31	29.5	9.38	35.2	11.36	40.9	13.62	43.8	14.83	46.7	16.07	52.4	18.71	58.1	21.57
	33	29.5	9.88	35.2	12.05	40.9	14.46	43.8	15.75	46.7	17.09	52.4	19.91	58.1	23.00
35	29.5	10.48	35.2	12.79	40.9	15.33	43.8	16.72	46.7	18.15	52.4	21.20	58.1	24.48	
37	29.5	11.08	35.2	13.53	40.9	16.26	43.8	17.74	46.7	19.26	52.4	22.54	58.1	26.05	
39	29.5	11.69	35.2	14.32	40.9	17.23	43.8	18.80	46.7	20.46	52.4	23.92	58.1	27.71	
41	29.5	12.06	35.2	14.94	40.9	17.85	43.8	19.55	46.7	21.21	52.4	25.05	58.1	28.97	
43	29.5	12.44	35.2	15.57	40.9	18.48	43.8	20.14	46.7	21.95	52.4	26.12	58.1	30.22	
45	29.5	13.02	35.2	16.35	40.9	19.23	43.8	20.89	46.7	23.04	52.4	27.29	58.1	31.89	
48	29.5	13.51	35.2	17.05	40.9	19.90	43.8	21.40	46.7	23.91	52.4	28.26	58.1	33.44	

Abbreviations:
 CR: Combination ratio
 TC: Total capacity (kW)
 PI: Power input (compressor + outdoor fan motor) (kW)

Notes:
 Shaded cells indicate rating condition.

Table continued on next page ...

Table 2-8.10: 26HP cooling capacity (continued)

Combination (%) (Capacity index)	Outdoor temperature (°C DB)	Indoor temperature(°C DB/WB)													
		DB:20.8,WB:14		DB:23.3,WB:16		DB:25.8,WB:18		DB:27,WB:19		DB:28.2,WB:20		DB:30.7,WB:22		DB:32,WB:24	
		TC	PI	TC	PI	TC	PI	TC	PI	TC	PI	TC	PI	TC	PI
50%	-5	24.6	5.55	29.5	6.41	34.2	7.37	36.5	7.72	38.8	8.14	43.5	9.26	48.5	9.98
	-2	24.6	5.59	29.5	6.54	34.2	7.45	36.5	7.82	38.8	8.29	43.5	9.38	48.5	10.11
	0	24.6	5.68	29.5	6.65	34.2	7.58	36.5	7.93	38.8	8.38	43.5	9.54	48.5	10.28
	2	24.6	5.76	29.5	6.73	34.2	7.72	36.5	8.05	38.8	8.53	43.5	9.58	48.5	10.48
	4	24.6	5.82	29.5	6.85	34.2	7.80	36.5	8.14	38.8	8.70	43.5	9.82	48.5	10.75
	6	24.6	5.92	29.5	6.96	34.2	7.91	36.5	8.33	38.8	8.86	43.5	9.97	48.5	11.07
	8	24.6	6.07	29.5	7.08	34.2	8.05	36.5	8.51	38.8	8.98	43.5	10.13	48.5	11.42
	10	24.6	6.19	29.5	7.16	34.2	8.18	36.5	8.65	38.8	9.24	43.5	10.39	48.5	11.59
	12	24.6	6.24	29.5	7.25	34.2	8.31	36.5	8.82	38.8	9.42	43.5	10.58	48.5	11.78
	14	24.6	6.33	29.5	7.34	34.2	8.41	36.5	9.01	38.8	9.56	43.5	10.76	48.5	12.01
	16	24.6	6.42	29.5	7.44	34.2	8.55	36.5	9.15	38.8	9.70	43.5	10.95	48.5	12.19
	18	24.6	6.51	29.5	7.57	34.2	8.68	36.5	9.28	38.8	9.88	43.5	11.13	48.5	12.42
	20	24.6	6.60	29.5	7.67	34.2	8.82	36.5	9.42	38.8	10.07	43.5	11.32	48.5	12.66
	21	24.6	6.65	29.5	7.76	34.2	8.91	36.5	9.52	38.8	10.16	43.5	11.45	48.5	12.79
	23	24.6	6.74	29.5	7.85	34.2	9.05	36.5	9.70	38.8	10.35	43.5	11.64	48.5	13.07
	25	24.6	6.84	29.5	7.99	34.2	9.24	36.5	9.88	38.8	10.67	43.5	12.24	48.5	13.95
	27	24.6	6.97	29.5	8.31	34.2	9.75	36.5	10.53	38.8	11.32	43.5	13.03	48.5	14.87
	29	24.6	7.34	29.5	8.78	34.2	10.35	36.5	11.18	38.8	12.06	43.5	13.86	48.5	15.84
	31	24.6	7.76	29.5	9.28	34.2	10.95	36.5	11.87	38.8	12.79	43.5	14.73	48.5	16.86
	33	24.6	8.22	29.5	9.84	34.2	11.64	36.5	12.56	38.8	13.58	43.5	15.66	48.5	17.92
35	24.6	8.68	29.5	10.39	34.2	12.29	36.5	13.30	38.8	14.37	43.5	16.63	48.5	19.03	
37	24.6	9.15	29.5	10.99	34.2	13.03	36.5	14.09	38.8	15.24	43.5	17.64	48.5	20.23	
39	24.6	9.65	29.5	11.59	34.2	13.76	36.5	14.92	38.8	16.17	43.5	18.71	48.5	21.48	
41	24.6	10.05	29.5	12.09	34.2	14.26	36.5	15.62	38.8	16.86	43.5	19.70	48.5	22.48	
43	24.6	10.72	29.5	12.92	34.2	14.76	36.5	16.32	38.8	17.30	43.5	20.70	48.5	23.47	
45	24.6	10.96	29.5	13.26	34.2	15.76	36.5	17.58	38.8	18.03	43.5	22.70	48.5	25.47	
48	24.6	11.17	29.5	13.57	34.2	16.63	36.5	18.76	38.8	18.89	43.5	24.48	48.5	27.40	

Abbreviations:

CR: Combination ratio

TC: Total capacity (kW)

PI: Power input (compressor + outdoor fan motor) (kW)

Notes:

Shaded cells indicate rating condition.

Table 2-8.11: 28HP cooling capacity

Combination (%) (Capacity index)	Outdoor temperature (°C DB)	Indoor temperature(°C DB/WB)													
		DB:20.8,WB:14		DB:23.3,WB:16		DB:25.8,WB:18		DB:27,WB:19		DB:28.2,WB:20		DB:30.7,WB:22		DB:32,WB:24	
		TC	PI	TC	PI	TC	PI	TC	PI	TC	PI	TC	PI	TC	PI
130%	-5	66.3	15.22	79.0	18.58	91.7	19.92	95.2	20.73	99.8	21.31	102.2	23.18	104.8	23.32
	-2	66.3	15.22	79.0	18.94	91.7	19.92	95.2	20.85	99.8	21.31	102.2	23.47	104.8	23.56
	0	66.3	15.48	79.0	19.27	91.7	20.65	95.2	21.99	99.8	22.55	102.2	23.76	104.8	23.87
	2	66.3	15.76	79.0	19.31	91.7	21.35	95.2	23.23	99.8	22.81	102.2	23.93	104.8	24.22
	4	66.3	16.11	79.0	19.68	91.7	22.09	95.2	23.33	99.8	23.11	102.2	24.30	104.8	24.69
	6	66.3	16.42	79.0	20.08	91.7	22.91	95.2	23.52	98.6	23.83	100.9	24.67	103.6	24.87
	8	66.3	16.82	79.0	20.54	91.7	24.05	95.2	24.67	97.4	24.60	99.8	24.75	102.3	25.11
	10	66.3	17.17	79.0	20.98	91.7	24.94	95.2	25.50	96.3	25.06	98.7	25.13	101.1	25.84
	12	66.3	17.47	79.0	21.38	91.7	25.44	93.8	25.88	95.2	25.44	97.3	25.51	99.8	26.00
	14	66.3	17.82	79.0	21.78	91.4	25.82	92.8	26.26	93.8	25.82	96.3	25.89	98.7	26.59
	16	66.3	18.12	79.0	22.23	90.3	26.20	91.4	26.60	92.5	26.58	94.9	26.27	97.3	27.01
	18	66.3	18.47	79.0	22.69	89.0	26.60	90.1	26.75	91.4	26.90	93.8	27.15	96.3	27.40
	20	66.3	18.87	79.0	24.14	87.6	27.91	89.0	28.05	90.1	28.21	92.5	28.46	94.9	28.76
	21	66.3	19.37	79.0	25.00	87.1	28.56	88.4	28.71	89.5	28.86	91.9	29.16	94.4	29.41
	23	66.3	20.78	79.0	26.80	86.0	29.86	87.1	30.01	88.2	30.16	90.6	30.46	93.0	30.77
	25	66.3	22.18	79.0	28.71	84.7	31.17	85.7	31.32	87.1	31.52	89.5	31.82	91.9	32.12
	27	66.3	23.69	79.0	30.72	83.6	32.47	84.7	32.67	85.7	32.82	88.2	33.18	90.6	33.52
	29	66.3	25.30	79.0	32.82	82.2	33.78	83.3	33.98	84.7	34.18	87.1	34.53	89.5	34.88
	31	66.3	27.00	78.7	34.73	80.9	35.13	82.2	35.33	83.3	35.48	85.7	35.88	88.2	36.29
	33	66.3	28.76	77.4	36.04	79.8	36.44	80.9	36.64	82.2	36.84	84.7	37.24	86.8	37.64
35	66.3	30.66	76.0	37.34	78.5	37.79	79.8	37.99	80.9	38.19	83.3	38.65	85.7	39.05	
37	66.3	32.62	75.0	38.70	77.4	39.15	78.5	39.35	79.8	39.60	82.0	40.05	84.4	40.50	
39	66.3	34.73	73.6	39.10	76.0	40.45	77.4	40.70	78.5	40.95	80.9	41.40	83.3	41.91	
41	66.3	36.55	72.9	39.48	75.2	40.83	76.6	41.08	77.7	41.33	80.1	41.49	80.1	42.29	
43	66.3	37.48	72.3	39.67	74.8	40.95	76.2	41.27	76.9	41.39	78.6	41.56	79.2	42.38	
45	66.3	39.34	71.9	40.05	74.0	41.32	75.4	41.54	75.7	41.58	76.5	41.72	77.6	43.18	
48	66.3	40.70	71.6	41.32	72.8	41.67	74.2	41.88	74.8	42.02	74.5	42.44	75.8	43.34	
120%	-5	61.2	14.70	72.8	17.81	84.7	21.06	90.6	22.96	94.9	23.94	97.1	24.70	99.2	25.36
	-2	61.2	14.85	72.8	17.99	84.7	21.27	90.6	23.10	94.9	24.22	97.1	24.91	99.2	25.45
	0	61.2	14.98	72.8	18.12	84.7	21.51	90.6	23.15	94.9	24.44	97.1	25.06	99.2	25.50
	2	61.2	15.02	72.8	18.30	84.7	21.66	90.6	23.38	94.9	24.53	97.1	25.24	99.2	25.55
	4	61.2	15.17	72.8	18.54	84.7	21.96	90.6	23.59	94.9	24.86	97.1	25.30	99.2	25.62
	6	61.2	15.33	72.8	18.68	84.7	22.23	90.6	23.85	94.9	25.13	97.1	25.50	99.2	25.70
	8	61.2	15.47	72.8	18.87	84.7	22.53	90.6	24.15	94.9	25.38	97.1	25.59	99.2	25.83
	10	61.2	15.66	72.8	19.12	84.7	22.73	90.6	24.59	94.9	25.40	97.1	25.66	99.2	25.94
	12	61.2	15.96	72.8	19.47	84.7	23.18	90.6	25.04	93.6	25.50	95.7	25.52	97.9	26.10
	14	61.2	16.26	72.8	19.87	84.7	23.64	90.6	25.55	92.2	25.66	94.6	25.91	96.8	26.42
	16	61.2	16.56	72.8	20.27	84.7	24.09	90.1	26.00	91.1	26.04	93.3	26.34	95.5	26.82
	18	61.2	16.86	72.8	20.68	84.7	24.89	88.7	26.60	89.8	26.70	91.9	26.95	94.4	27.20
	20	61.2	17.21	72.8	21.48	84.7	26.80	87.6	27.90	88.7	28.00	90.9	28.26	93.0	28.50
	21	61.2	17.36	72.8	22.23	84.7	27.75	86.8	28.55	87.9	28.66	90.3	28.91	92.5	29.21
	23	61.2	18.57	72.8	23.84	84.7	29.71	85.7	29.81	86.8	29.96	89.0	30.26	91.1	30.51
	25	61.2	19.82	72.8	25.49	83.3	31.01	84.4	31.12	85.5	31.27	87.9	31.57	90.1	31.87
	27	61.2	21.18	72.8	27.25	82.2	32.27	83.3	32.47	84.4	32.62	86.6	32.92	88.7	33.22
	29	61.2	22.58	72.8	29.11	80.9	33.57	82.0	33.77	83.1	33.92	85.2	34.28	87.6	34.58
	31	61.2	24.09	72.8	31.06	79.5	34.93	80.9	35.08	82.0	35.28	84.1	35.63	86.3	35.98
	33	61.2	25.64	72.8	33.12	78.5	36.23	79.5	36.43	80.6	36.58	82.8	36.99	84.9	37.34
35	61.2	27.30	72.8	35.33	77.1	37.53	78.2	37.74	79.5	37.94	81.7	38.34	83.9	38.74	
37	61.2	29.06	72.8	37.64	76.0	38.89	77.1	39.09	78.2	39.29	80.4	39.70	82.5	40.15	
39	61.2	30.91	72.5	39.75	74.7	40.20	75.8	40.45	76.9	40.65	79.3	41.10	81.4	41.50	
41	61.2	31.76	71.9	40.03	74.1	40.48	75.2	40.73	76.3	40.93	78.7	41.22	79.1	41.81	
43	61.2	32.23	71.6	40.31	73.5	40.73	74.6	40.89	75.7	41.08	77.3	41.33	77.9	42.65	
45	61.2	32.61	71.2	40.69	72.8	41.11	73.8	41.27	75.0	41.40	75.8	41.46	77.1	43.58	
48	61.2	32.83	70.6	41.14	71.9	41.47	72.6	41.51	74.2	41.78	74.6	41.89	76.1	44.12	

Abbreviations:

CR: Combination ratio

TC: Total capacity (kW)

PI: Power input (compressor + outdoor fan motor) (kW)

Notes:

Shaded cells indicate rating condition.

Table continued on next page ...

Table 2-8.11: 28HP cooling capacity (continued)

Combination (%) (Capacity index)	Outdoor temperature (°C DB)	Indoor temperature(°C DB/WB)													
		DB:20.8,WB:14		DB:23.3,WB:16		DB:25.8,WB:18		DB:27,WB:19		DB:28.2,WB:20		DB:30.7,WB:22		DB:32,WB:24	
		TC kW	PI kW	TC kW	PI kW	TC kW	PI kW	TC kW	PI kW	TC kW	PI kW	TC kW	PI kW	TC kW	PI kW
110%	-5	56.1	12.84	66.9	15.98	77.7	19.07	83.1	20.47	88.4	22.03	95.2	22.88	97.3	23.58
	-2	56.1	13.08	66.9	16.19	77.7	19.23	83.1	20.68	88.4	22.20	95.2	23.10	97.3	23.71
	0	56.1	13.22	66.9	16.28	77.7	19.38	83.1	20.81	88.4	22.45	95.2	23.33	97.3	23.99
	2	56.1	13.50	66.9	16.44	77.7	19.68	83.1	21.03	88.4	22.69	95.2	23.66	97.3	24.29
	4	56.1	13.77	66.9	16.62	77.7	19.87	83.1	21.29	88.4	23.03	95.2	23.99	97.3	24.52
	6	56.1	13.91	66.9	16.81	77.7	20.06	83.1	21.63	88.4	23.29	95.2	24.24	97.3	24.89
	8	56.1	14.04	66.9	17.08	77.7	20.29	83.1	21.86	88.4	23.56	95.2	24.41	97.3	25.16
	10	56.1	14.20	66.9	17.31	77.7	20.58	83.1	22.23	88.4	23.94	95.2	24.58	97.3	25.37
	12	56.1	14.50	66.9	17.67	77.7	20.98	83.1	22.69	88.4	24.39	94.1	24.94	96.0	25.70
	14	56.1	14.76	66.9	17.97	77.7	21.38	83.1	23.09	88.4	24.84	92.8	25.14	94.9	25.89
	16	56.1	15.01	66.9	18.32	77.7	21.78	83.1	23.54	88.4	25.34	91.7	25.44	93.6	26.17
	18	56.1	15.31	66.9	18.67	77.7	22.23	83.1	24.19	88.4	26.55	90.3	26.75	92.5	27.00
	20	56.1	15.61	66.9	19.07	77.7	23.54	83.1	26.00	87.1	27.86	89.3	28.05	91.1	28.31
	21	56.1	15.76	66.9	19.62	77.7	24.39	83.1	26.95	86.6	28.51	88.4	28.71	90.6	28.96
	23	56.1	16.51	66.9	21.03	77.7	26.15	83.1	28.91	85.2	29.76	87.4	30.06	89.3	30.31
	25	56.1	17.62	66.9	22.48	77.7	27.95	83.1	30.97	84.1	31.06	86.0	31.37	88.2	31.62
	27	56.1	18.77	66.9	24.04	77.7	29.91	81.7	32.27	82.8	32.37	84.9	32.67	86.8	32.97
	29	56.1	20.02	66.9	25.65	77.7	31.97	80.6	33.58	81.7	33.73	83.6	34.03	85.8	34.33
	31	56.1	21.33	66.9	27.35	77.7	34.13	79.3	34.88	80.4	35.03	82.5	35.33	84.4	35.68
	33	56.1	22.69	66.9	29.16	77.1	35.98	78.2	36.19	79.3	36.34	81.2	36.69	83.3	37.04
35	56.1	24.14	66.9	31.06	75.8	37.29	76.9	37.49	77.9	37.69	79.8	38.04	82.0	38.39	
37	56.1	25.70	66.9	33.07	74.7	38.64	75.8	38.79	76.6	39.00	78.7	39.40	80.6	39.75	
39	56.1	27.30	66.9	35.23	73.3	39.95	74.4	40.15	75.5	40.35	77.4	40.75	79.5	41.15	
41	56.1	27.58	66.9	35.51	72.8	40.23	73.8	40.43	74.9	40.63	76.4	41.03	77.2	41.43	
43	56.1	27.86	66.9	35.97	72.2	40.51	73.3	40.71	74.4	40.91	75.7	41.18	76.0	42.28	
45	56.1	28.76	66.9	36.17	71.5	40.89	72.5	41.20	73.7	41.29	75.0	42.31	75.3	43.26	
48	56.1	29.71	66.9	39.15	70.4	41.07	71.3	41.40	72.9	41.65	73.7	42.38	74.3	43.63	
100%	-5	51.0	11.69	60.7	14.08	70.6	16.76	75.5	17.95	80.4	19.47	90.3	22.19	95.5	23.16
	-2	51.0	11.83	60.7	14.26	70.6	16.94	75.5	18.28	80.4	19.74	90.3	22.45	95.5	23.31
	0	51.0	11.95	60.7	14.41	70.6	17.13	75.5	18.51	80.4	19.92	90.3	22.83	95.5	23.57
	2	51.0	12.19	60.7	14.61	70.6	17.32	75.5	18.75	80.4	20.15	90.3	23.16	95.5	23.94
	4	51.0	12.28	60.7	14.75	70.6	17.58	75.5	19.03	80.4	20.41	90.3	23.38	95.5	24.20
	6	51.0	12.46	60.7	15.04	70.6	17.80	75.5	19.36	80.4	20.70	90.3	23.72	95.5	24.58
	8	51.0	12.70	60.7	15.27	70.6	18.13	75.5	19.59	80.4	21.04	90.3	24.09	95.5	24.99
	10	51.0	12.85	60.7	15.56	70.6	18.42	75.5	19.92	80.4	21.43	90.3	24.49	95.5	25.34
	12	51.0	13.05	60.7	15.86	70.6	18.77	75.5	20.28	80.4	21.83	90.3	24.94	94.1	25.54
	14	51.0	13.30	60.7	16.16	70.6	19.12	75.5	20.68	80.4	22.23	90.3	25.44	93.0	25.85
	16	51.0	13.55	60.7	16.46	70.6	19.52	75.5	21.08	80.4	22.68	89.8	25.75	91.7	26.15
	18	51.0	13.80	60.7	16.76	70.6	19.87	75.5	21.48	80.4	23.14	88.7	26.60	90.6	26.80
	20	51.0	14.05	60.7	17.11	70.6	20.48	75.5	22.58	80.4	24.79	87.4	27.85	89.2	28.10
	21	51.0	14.20	60.7	17.26	70.6	21.23	75.5	23.38	80.4	25.65	86.8	28.50	88.7	28.75
	23	51.0	14.55	60.7	18.42	70.6	22.73	75.5	25.04	80.4	27.50	85.7	29.81	87.4	30.06
	25	51.0	15.51	60.7	19.67	70.6	24.34	75.5	26.85	80.4	29.46	84.4	31.12	86.3	31.36
	27	51.0	16.56	60.7	20.98	70.6	26.00	75.5	28.71	80.4	31.52	83.1	32.42	84.9	32.72
	29	51.0	17.61	60.7	22.38	70.6	27.75	75.5	30.66	80.1	33.47	82.0	33.77	83.9	34.02
	31	51.0	18.77	60.7	23.89	70.6	29.61	75.5	32.72	79.0	34.78	80.6	35.08	82.5	35.38
	33	51.0	19.92	60.7	25.44	70.6	31.57	75.5	34.93	77.7	36.08	79.5	36.38	81.4	36.73
35	51.0	21.18	60.7	27.05	70.6	33.67	75.5	37.24	76.3	37.39	78.2	37.74	80.1	38.04	
37	51.0	22.53	60.7	28.81	70.6	35.88	74.1	38.54	75.2	38.74	77.1	39.09	78.7	39.40	
39	51.0	23.94	60.7	30.61	70.6	38.19	73.1	39.85	73.9	40.05	75.8	40.40	77.7	40.80	
41	51.0	25.05	60.7	31.73	70.6	39.59	71.9	40.13	73.3	40.66	74.5	41.35	76.5	41.64	
43	51.0	26.17	60.7	32.85	70.6	40.32	70.8	40.59	72.8	41.06	74.9	41.62	75.2	42.10	
45	51.0	27.66	60.7	34.34	70.6	41.01	69.3	41.15	72.4	41.80	74.3	42.26	73.7	42.66	
48	51.0	28.88	60.7	35.54	70.6	41.08	66.4	41.62	72.3	42.54	69.7	42.70	72.1	43.06	

Abbreviations:

CR: Combination ratio

TC: Total capacity (kW)

PI: Power input (compressor + outdoor fan motor) (kW)

Notes:

Shaded cells indicate rating condition.

Table continued on next page ...

Table 2-8.11: 28HP cooling capacity (continued)

Combination (%) (Capacity index)	Outdoor temperature (°C DB)	Indoor temperature(°C DB/WB)													
		DB:20.8,WB:14		DB:23.3,WB:16		DB:25.8,WB:18		DB:27,WB:19		DB:28.2,WB:20		DB:30.7,WB:22		DB:32,WB:24	
		TC kW	PI kW	TC kW	PI kW	TC kW	PI kW	TC kW	PI kW	TC kW	PI kW	TC kW	PI kW	TC kW	PI kW
90%	-5	45.8	10.34	54.7	12.41	63.6	14.64	68.0	15.97	72.3	16.99	81.2	19.53	90.1	22.37
	-2	45.8	10.44	54.7	12.54	63.6	14.83	68.0	16.19	72.3	17.20	81.2	19.73	90.1	22.59
	0	45.8	10.59	54.7	12.69	63.6	15.05	68.0	16.38	72.3	17.42	81.2	19.95	90.1	22.76
	2	45.8	10.75	54.7	12.85	63.6	15.21	68.0	16.64	72.3	17.69	81.2	20.36	90.1	23.10
	4	45.8	10.92	54.7	13.04	63.6	15.46	68.0	16.86	72.3	17.91	81.2	20.68	90.1	23.44
	6	45.8	11.07	54.7	13.30	63.6	15.75	68.0	17.18	72.3	18.23	81.2	21.00	90.1	23.83
	8	45.8	11.28	54.7	13.55	63.6	16.07	68.0	17.40	72.3	18.55	81.2	21.39	90.1	24.05
	10	45.8	11.49	54.7	13.85	63.6	16.36	68.0	17.66	72.3	18.97	81.2	21.67	90.1	24.44
	12	45.8	11.69	54.7	14.10	63.6	16.66	68.0	17.96	72.3	19.32	81.2	22.08	90.1	24.89
	14	45.8	11.89	54.7	14.35	63.6	16.96	68.0	18.32	72.3	19.67	81.2	22.48	90.1	25.34
	16	45.8	12.09	54.7	14.60	63.6	17.31	68.0	18.67	72.3	20.07	81.2	22.93	89.8	25.79
	18	45.8	12.29	54.7	14.91	63.6	17.61	68.0	19.02	72.3	20.47	81.2	23.38	88.7	26.60
	20	45.8	12.54	54.7	15.25	63.6	17.97	68.0	19.42	72.3	21.23	81.2	25.14	87.4	27.85
	21	45.8	12.65	54.7	15.35	63.6	18.27	68.0	20.07	72.3	21.98	81.2	26.04	86.8	28.50
	23	45.8	12.90	54.7	15.96	63.6	19.57	68.0	21.53	72.3	23.58	81.2	27.95	85.5	29.81
	25	45.8	13.60	54.7	17.06	63.6	20.92	68.0	23.03	72.3	25.19	81.2	29.91	84.4	31.11
	27	45.8	14.45	54.7	18.17	63.6	22.33	68.0	24.59	72.3	26.95	81.2	32.02	83.0	32.42
	29	45.8	15.40	54.7	19.37	63.6	23.84	68.0	26.24	72.3	28.81	80.4	33.47	82.0	33.72
	31	45.8	16.36	54.7	20.63	63.6	25.39	68.0	28.00	72.3	30.71	79.0	34.78	80.6	35.08
	33	45.8	17.36	54.7	21.93	63.6	27.10	68.0	29.86	72.3	32.77	77.9	36.13	79.5	36.38
35	45.8	18.47	54.7	23.33	63.6	28.85	68.0	31.82	72.3	34.93	76.6	37.44	78.2	37.74	
37	45.8	19.57	54.7	24.79	63.6	30.71	68.0	33.87	72.3	37.23	75.2	38.74	77.1	39.04	
39	45.8	20.78	54.7	26.40	63.6	32.67	68.0	36.08	72.3	39.65	74.2	40.10	75.8	40.40	
41	45.8	21.49	54.7	27.59	63.6	33.86	68.0	37.04	72.3	39.88	73.6	41.12	75.3	41.35	
43	45.8	22.53	54.7	28.78	63.6	35.05	68.0	37.99	72.3	40.73	73.3	41.65	74.6	41.99	
45	45.8	23.96	54.7	30.22	63.6	36.49	68.0	39.26	72.3	41.86	72.9	42.09	73.5	42.55	
48	45.8	25.29	54.7	31.61	63.6	37.86	68.0	39.76	72.3	42.22	72.2	42.67	71.5	43.13	
80%	-5	40.7	9.11	48.5	10.77	56.4	12.76	60.4	13.56	64.4	14.61	72.3	16.88	80.1	19.27
	-2	40.7	9.25	48.5	10.91	56.4	12.86	60.4	13.77	64.4	14.74	72.3	17.04	80.1	19.46
	0	40.7	9.41	48.5	11.04	56.4	13.02	60.4	13.94	64.4	15.01	72.3	17.29	80.1	19.72
	2	40.7	9.59	48.5	11.20	56.4	13.21	60.4	14.20	64.4	15.28	72.3	17.63	80.1	20.10
	4	40.7	9.76	48.5	11.39	56.4	13.46	60.4	14.53	64.4	15.54	72.3	17.96	80.1	20.37
	6	40.7	9.92	48.5	11.66	56.4	13.67	60.4	14.85	64.4	15.84	72.3	18.22	80.1	20.72
	8	40.7	10.10	48.5	11.93	56.4	13.99	60.4	15.09	64.4	16.19	72.3	18.49	80.1	21.12
	10	40.7	10.19	48.5	12.20	56.4	14.35	60.4	15.46	64.4	16.56	72.3	18.92	80.1	21.33
	12	40.7	10.34	48.5	12.39	56.4	14.60	60.4	15.76	64.4	16.91	72.3	19.27	80.1	21.73
	14	40.7	10.54	48.5	12.65	56.4	14.85	60.4	16.01	64.4	17.21	72.3	19.62	80.1	22.13
	16	40.7	10.69	48.5	12.85	56.4	15.16	60.4	16.31	64.4	17.52	72.3	20.02	80.1	22.53
	18	40.7	10.89	48.5	13.10	56.4	15.46	60.4	16.66	64.4	17.87	72.3	20.43	80.1	22.99
	20	40.7	11.09	48.5	13.35	56.4	15.76	60.4	16.96	64.4	18.22	72.3	21.18	80.1	24.59
	21	40.7	11.19	48.5	13.45	56.4	15.91	60.4	17.16	64.4	18.62	72.3	21.93	80.1	25.49
	23	40.7	11.39	48.5	13.75	56.4	16.66	60.4	18.27	64.4	19.92	72.3	23.49	80.1	27.35
	25	40.7	11.74	48.5	14.60	56.4	17.82	60.4	19.52	64.4	21.28	72.3	25.14	80.1	29.26
	27	40.7	12.50	48.5	15.56	56.4	18.97	60.4	20.83	64.4	22.73	72.3	26.85	80.1	31.32
	29	40.7	13.30	48.5	16.56	56.4	20.23	60.4	22.18	64.4	24.29	72.3	28.66	80.1	33.48
	31	40.7	14.10	48.5	17.62	56.4	21.53	60.4	23.64	64.4	25.90	72.3	30.61	78.7	34.78
	33	40.7	15.01	48.5	18.72	56.4	22.94	60.4	25.19	64.4	27.55	72.3	32.62	77.7	36.08
35	40.7	15.91	48.5	19.92	56.4	24.39	60.4	26.80	64.4	29.36	72.3	34.78	76.3	37.39	
37	40.7	16.86	48.5	21.13	56.4	25.95	60.4	28.55	64.4	31.27	72.3	37.09	75.2	38.69	
39	40.7	17.87	48.5	22.53	56.4	27.60	60.4	30.36	64.4	33.27	72.3	39.50	73.9	40.05	
41	40.7	18.27	48.5	22.73	56.4	28.01	60.4	31.17	64.4	33.88	72.3	40.50	73.4	40.75	
43	40.7	18.81	48.5	22.94	56.4	28.41	60.4	31.70	64.4	34.35	72.3	40.97	73.0	41.19	
45	40.7	19.34	48.5	23.20	56.4	28.96	60.4	32.37	64.4	34.94	72.3	41.42	72.1	41.87	
48	40.7	19.97	48.5	23.34	56.4	29.40	60.4	32.80	64.4	35.21	72.3	41.81	71.5	42.40	

Abbreviations:

CR: Combination ratio

TC: Total capacity (kW)

PI: Power input (compressor + outdoor fan motor) (kW)

Notes:

Shaded cells indicate rating condition.

Table continued on next page ...

Table 2-8.11: 28HP cooling capacity (continued)

Combination (%) (Capacity index)	Outdoor temperature (°C DB)	Indoor temperature(°C DB/WB)													
		DB:20.8,WB:14		DB:23.3,WB:16		DB:25.8,WB:18		DB:27,WB:19		DB:28.2,WB:20		DB:30.7,WB:22		DB:32,WB:24	
		TC	PI	TC	PI	TC	PI	TC	PI	TC	PI	TC	PI	TC	PI
70%	-5	35.6	8.13	42.6	9.54	49.3	10.81	52.9	11.59	56.4	12.37	63.1	14.15	70.1	16.27
	-2	35.6	8.20	42.6	9.58	49.3	10.87	52.9	11.81	56.4	12.59	63.1	14.37	70.1	16.49
	0	35.6	8.24	42.6	9.72	49.3	11.10	52.9	12.03	56.4	12.81	63.1	14.66	70.1	16.71
	2	35.6	8.29	42.6	9.76	49.3	11.28	52.9	12.26	56.4	13.04	63.1	14.97	70.1	16.98
	4	35.6	8.40	42.6	10.00	49.3	11.52	52.9	12.48	56.4	13.33	63.1	15.22	70.1	17.38
	6	35.6	8.53	42.6	10.18	49.3	11.81	52.9	12.88	56.4	13.64	63.1	15.49	70.1	17.71
	8	35.6	8.69	42.6	10.47	49.3	12.08	52.9	13.08	56.4	13.93	63.1	15.93	70.1	18.05
	10	35.6	8.87	42.6	10.64	49.3	12.40	52.9	13.35	56.4	14.30	63.1	16.26	70.1	18.27
	12	35.6	9.08	42.6	10.79	49.3	12.65	52.9	13.60	56.4	14.56	63.1	16.56	70.1	18.62
	14	35.6	9.23	42.6	10.99	49.3	12.85	52.9	13.80	56.4	14.80	63.1	16.86	70.1	18.97
	16	35.6	9.39	42.6	11.19	49.3	13.10	52.9	14.10	56.4	15.11	63.1	17.16	70.1	19.32
	18	35.6	9.53	42.6	11.39	49.3	13.35	52.9	14.35	56.4	15.36	63.1	17.51	70.1	19.72
	20	35.6	9.69	42.6	11.59	49.3	13.60	52.9	14.60	56.4	15.66	63.1	17.87	70.1	20.27
	21	35.6	9.79	42.6	11.69	49.3	13.70	52.9	14.76	56.4	15.81	63.1	18.12	70.1	20.98
	23	35.6	9.94	42.6	11.89	49.3	14.00	52.9	15.26	56.4	16.61	63.1	19.42	70.1	22.48
	25	35.6	10.14	42.6	12.40	49.3	14.90	52.9	16.31	56.4	17.71	63.1	20.78	70.1	24.04
	27	35.6	10.74	42.6	13.20	49.3	15.91	52.9	17.36	56.4	18.92	63.1	22.18	70.1	25.70
	29	35.6	11.39	42.6	14.00	49.3	16.91	52.9	18.52	56.4	20.13	63.1	23.64	70.1	27.45
	31	35.6	12.04	42.6	14.86	49.3	18.02	52.9	19.67	56.4	21.43	63.1	25.19	70.1	29.26
	33	35.6	12.80	42.6	15.81	49.3	19.17	52.9	20.93	56.4	22.84	63.1	26.85	70.1	31.22
35	35.6	13.55	42.6	16.76	49.3	20.33	52.9	22.28	56.4	24.29	63.1	28.61	70.1	33.27	
37	35.6	14.30	42.6	17.77	49.3	21.63	52.9	23.64	56.4	25.85	63.1	30.46	70.1	35.43	
39	35.6	15.16	42.6	18.82	49.3	22.94	52.9	25.14	56.4	27.45	63.1	32.37	70.1	37.74	
41	35.6	15.83	42.6	19.49	49.3	23.60	52.9	25.98	56.4	28.29	63.1	33.71	70.1	39.41	
43	35.6	17.11	42.6	20.83	49.3	24.58	52.9	27.37	56.4	29.12	63.1	34.93	70.1	40.64	
45	35.6	17.49	42.6	21.27	49.3	25.09	52.9	27.82	56.4	30.57	63.1	36.83	70.1	42.20	
48	35.6	17.83	42.6	21.39	49.3	25.40	52.9	28.30	56.4	31.42	63.1	38.55	70.1	43.23	
60%	-5	30.5	6.94	36.4	8.05	42.3	9.38	45.3	9.99	48.3	10.79	54.2	12.12	60.1	13.90
	-2	30.5	6.98	36.4	8.17	42.3	9.55	45.3	10.14	48.3	10.90	54.2	12.30	60.1	13.99
	0	30.5	7.08	36.4	8.27	42.3	9.67	45.3	10.26	48.3	11.08	54.2	12.48	60.1	14.17
	2	30.5	7.21	36.4	8.46	42.3	9.85	45.3	10.46	48.3	11.23	54.2	12.73	60.1	14.35
	4	30.5	7.41	36.4	8.63	42.3	10.05	45.3	10.59	48.3	11.39	54.2	12.93	60.1	14.55
	6	30.5	7.48	36.4	8.79	42.3	10.24	45.3	10.83	48.3	11.63	54.2	13.19	60.1	14.89
	8	30.5	7.63	36.4	8.94	42.3	10.43	45.3	11.03	48.3	11.86	54.2	13.44	60.1	15.13
	10	30.5	7.78	36.4	9.13	42.3	10.59	45.3	11.34	48.3	12.09	54.2	13.70	60.1	15.35
	12	30.5	7.93	36.4	9.28	42.3	10.79	45.3	11.54	48.3	12.29	54.2	13.95	60.1	15.60
	14	30.5	8.03	36.4	9.43	42.3	10.94	45.3	11.74	48.3	12.54	54.2	14.20	60.1	15.91
	16	30.5	8.13	36.4	9.58	42.3	11.14	45.3	11.94	48.3	12.75	54.2	14.45	60.1	16.21
	18	30.5	8.28	36.4	9.73	42.3	11.34	45.3	12.14	48.3	13.00	54.2	14.70	60.1	16.51
	20	30.5	8.38	36.4	9.94	42.3	11.54	45.3	12.39	48.3	13.25	54.2	15.00	60.1	16.86
	21	30.5	8.48	36.4	9.98	42.3	11.64	45.3	12.49	48.3	13.35	54.2	15.15	60.1	17.01
	23	30.5	8.58	36.4	10.19	42.3	11.84	45.3	12.75	48.3	13.60	54.2	15.76	60.1	18.11
	25	30.5	8.73	36.4	10.34	42.3	12.29	45.3	13.35	48.3	14.45	54.2	16.81	60.1	19.32
	27	30.5	9.08	36.4	10.99	42.3	13.10	45.3	14.25	48.3	15.41	54.2	17.91	60.1	20.62
	29	30.5	9.58	36.4	11.64	42.3	13.95	45.3	15.15	48.3	16.41	54.2	19.12	60.1	22.03
	31	30.5	10.19	36.4	12.34	42.3	14.80	45.3	16.11	48.3	17.46	54.2	20.32	60.1	23.43
	33	30.5	10.74	36.4	13.10	42.3	15.70	45.3	17.11	48.3	18.57	54.2	21.63	60.1	24.99
35	30.5	11.39	36.4	13.90	42.3	16.66	45.3	18.16	48.3	19.72	54.2	23.03	60.1	26.59	
37	30.5	12.04	36.4	14.70	42.3	17.66	45.3	19.27	48.3	20.92	54.2	24.49	60.1	28.30	
39	30.5	12.69	36.4	15.56	42.3	18.72	45.3	20.42	48.3	22.23	54.2	25.99	60.1	30.11	
41	30.5	13.10	36.4	16.23	42.3	19.40	45.3	21.24	48.3	23.05	54.2	27.22	60.1	31.47	
43	30.5	13.51	36.4	16.91	42.3	20.08	45.3	21.88	48.3	23.85	54.2	28.37	60.1	32.83	
45	30.5	14.15	36.4	17.77	42.3	20.90	45.3	22.69	48.3	25.03	54.2	29.64	60.1	34.65	
48	30.5	14.68	36.4	18.53	42.3	21.62	45.3	23.25	48.3	25.97	54.2	30.70	60.1	36.33	

Abbreviations:

CR: Combination ratio

TC: Total capacity (kW)

PI: Power input (compressor + outdoor fan motor) (kW)

Notes:

Shaded cells indicate rating condition.

Table continued on next page ...

Table 2-8.11: 28HP cooling capacity (continued)

Combination (%) (Capacity index)	Outdoor temperature (°C DB)	Indoor temperature(°C DB/WB)													
		DB:20.8,WB:14		DB:23.3,WB:16		DB:25.8,WB:18		DB:27,WB:19		DB:28.2,WB:20		DB:30.7,WB:22		DB:32,WB:24	
		TC	PI	TC	PI	TC	PI	TC	PI	TC	PI	TC	PI	TC	PI
50%	-5	25.5	6.03	30.5	6.97	35.3	8.01	37.8	8.38	40.2	8.84	45.0	10.06	50.2	10.84
	-2	25.5	6.07	30.5	7.11	35.3	8.09	37.8	8.50	40.2	9.00	45.0	10.19	50.2	10.98
	0	25.5	6.17	30.5	7.23	35.3	8.24	37.8	8.61	40.2	9.10	45.0	10.36	50.2	11.17
	2	25.5	6.26	30.5	7.31	35.3	8.38	37.8	8.74	40.2	9.26	45.0	10.41	50.2	11.39
	4	25.5	6.32	30.5	7.44	35.3	8.47	37.8	8.84	40.2	9.45	45.0	10.67	50.2	11.68
	6	25.5	6.44	30.5	7.56	35.3	8.60	37.8	9.05	40.2	9.62	45.0	10.83	50.2	12.02
	8	25.5	6.59	30.5	7.69	35.3	8.74	37.8	9.25	40.2	9.75	45.0	11.00	50.2	12.41
	10	25.5	6.72	30.5	7.78	35.3	8.88	37.8	9.39	40.2	10.04	45.0	11.29	50.2	12.59
	12	25.5	6.77	30.5	7.88	35.3	9.03	37.8	9.58	40.2	10.24	45.0	11.49	50.2	12.80
	14	25.5	6.87	30.5	7.98	35.3	9.13	37.8	9.79	40.2	10.39	45.0	11.69	50.2	13.05
	16	25.5	6.97	30.5	8.08	35.3	9.28	37.8	9.94	40.2	10.54	45.0	11.89	50.2	13.25
	18	25.5	7.08	30.5	8.23	35.3	9.43	37.8	10.09	40.2	10.74	45.0	12.09	50.2	13.50
	20	25.5	7.18	30.5	8.33	35.3	9.58	37.8	10.24	40.2	10.94	45.0	12.29	50.2	13.75
	21	25.5	7.23	30.5	8.43	35.3	9.68	37.8	10.34	40.2	11.04	45.0	12.44	50.2	13.90
	23	25.5	7.33	30.5	8.53	35.3	9.84	37.8	10.54	40.2	11.24	45.0	12.65	50.2	14.20
	25	25.5	7.43	30.5	8.68	35.3	10.04	37.8	10.74	40.2	11.59	45.0	13.30	50.2	15.15
	27	25.5	7.58	30.5	9.03	35.3	10.59	37.8	11.44	40.2	12.29	45.0	14.15	50.2	16.16
	29	25.5	7.98	30.5	9.53	35.3	11.24	37.8	12.14	40.2	13.10	45.0	15.05	50.2	17.21
	31	25.5	8.43	30.5	10.09	35.3	11.89	37.8	12.90	40.2	13.90	45.0	16.01	50.2	18.32
	33	25.5	8.93	30.5	10.69	35.3	12.65	37.8	13.65	40.2	14.75	45.0	17.01	50.2	19.47
35	25.5	9.43	30.5	11.29	35.3	13.35	37.8	14.45	40.2	15.61	45.0	18.06	50.2	20.67	
37	25.5	9.94	30.5	11.94	35.3	14.15	37.8	15.30	40.2	16.56	45.0	19.17	50.2	21.98	
39	25.5	10.49	30.5	12.59	35.3	14.95	37.8	16.21	40.2	17.56	45.0	20.32	50.2	23.33	
41	25.5	10.92	30.5	13.14	35.3	15.50	37.8	16.97	40.2	18.32	45.0	21.41	50.2	24.42	
43	25.5	11.64	30.5	14.04	35.3	16.04	37.8	17.73	40.2	18.79	45.0	22.49	50.2	25.50	
45	25.5	11.91	30.5	14.40	35.3	17.12	37.8	19.10	40.2	19.59	45.0	24.66	50.2	27.67	
48	25.5	12.14	30.5	14.74	35.3	18.06	37.8	20.38	40.2	20.52	45.0	26.59	50.2	29.77	

Abbreviations:

CR: Combination ratio

TC: Total capacity (kW)

PI: Power input (compressor + outdoor fan motor) (kW)

Notes:

Shaded cells indicate rating condition.

Table 2-8.12: 30HP cooling capacity (continued)

Combination (%) (Capacity index)	Outdoor temperature (°C DB)	Indoor temperature(°C DB/WB)													
		DB:20.8,WB:14		DB:23.3,WB:16		DB:25.8,WB:18		DB:27,WB:19		DB:28.2,WB:20		DB:30.7,WB:22		DB:32,WB:24	
		TC	PI	TC	PI	TC	PI	TC	PI	TC	PI	TC	PI	TC	PI
130%	-5	74.7	18.34	88.9	22.39	103.2	24.00	107.2	24.98	112.3	25.69	115.0	27.93	117.9	28.11
	-2	74.7	18.34	88.9	22.82	103.2	24.00	107.2	25.12	112.3	25.69	115.0	28.29	117.9	28.39
	0	74.7	18.66	88.9	23.22	103.2	24.88	107.2	26.50	112.3	27.18	115.0	28.63	117.9	28.77
	2	74.7	18.99	88.9	23.27	103.2	25.73	107.2	27.99	112.3	27.49	115.0	28.84	117.9	29.19
	4	74.7	19.42	88.9	23.72	103.2	26.62	107.2	28.11	112.3	27.85	115.0	29.28	117.9	29.75
	6	74.7	19.79	88.9	24.19	103.2	27.60	107.2	28.35	111.1	28.71	113.6	29.73	116.6	29.97
	8	74.7	20.27	88.9	24.75	103.2	28.99	107.2	29.73	109.7	29.65	112.4	29.83	115.2	30.26
	10	74.7	20.69	88.9	25.28	103.2	30.06	107.2	30.73	108.4	30.20	111.1	30.28	113.8	31.14
	12	74.7	21.05	88.9	25.76	103.2	30.66	105.6	31.19	107.2	30.66	109.6	30.74	112.3	31.33
	14	74.7	21.47	88.9	26.25	102.9	31.12	104.4	31.64	105.6	31.12	108.4	31.20	111.1	32.04
	16	74.7	21.84	88.9	26.79	101.7	31.58	102.9	32.06	104.1	32.03	106.9	31.66	109.6	32.55
	18	74.7	22.26	88.9	27.34	100.2	32.06	101.4	32.24	102.9	32.42	105.6	32.72	108.4	33.03
	20	74.7	22.74	88.9	29.09	98.7	33.63	100.2	33.81	101.4	33.99	104.1	34.29	106.9	34.66
	21	74.7	23.35	88.9	30.12	98.0	34.42	99.6	34.60	100.8	34.78	103.5	35.14	106.2	35.44
	23	74.7	25.04	88.9	32.30	96.8	35.99	98.0	36.17	99.3	36.35	102.0	36.71	104.7	37.08
	25	74.7	26.73	88.9	34.60	95.3	37.56	96.5	37.74	98.0	37.98	100.8	38.35	103.5	38.71
	27	74.7	28.55	88.9	37.02	94.1	39.13	95.3	39.37	96.5	39.56	99.3	39.98	102.0	40.40
	29	74.7	30.48	88.9	39.56	92.6	40.70	93.8	40.95	95.3	41.19	98.0	41.62	100.8	42.04
	31	74.7	32.54	88.6	41.85	91.1	42.34	92.6	42.58	93.8	42.76	96.5	43.25	99.3	43.73
	33	74.7	34.66	87.1	43.43	89.9	43.91	91.1	44.15	92.6	44.39	95.3	44.88	97.7	45.37
	35	74.7	36.95	85.6	45.00	88.3	45.54	89.9	45.79	91.1	46.03	93.8	46.57	96.5	47.06
	37	74.7	39.32	84.4	46.63	87.1	47.18	88.3	47.42	89.9	47.72	92.3	48.27	95.0	48.81
	39	74.7	41.85	82.9	47.12	85.6	48.75	87.1	49.05	88.3	49.35	91.1	49.90	93.8	50.50
	41	74.7	44.05	82.0	47.58	84.7	49.21	86.2	49.51	87.4	49.81	90.2	50.00	90.2	50.96
43	74.7	45.17	81.4	47.81	84.3	49.34	85.8	49.74	86.5	49.88	88.5	50.09	89.1	51.08	
45	74.7	47.41	80.9	48.26	83.4	49.80	84.9	50.06	85.3	50.11	86.1	50.27	87.4	52.04	
48	74.7	49.05	80.6	49.80	82.0	50.22	83.5	50.47	84.2	50.64	83.8	51.14	85.4	52.23	
120%	-5	68.9	17.72	82.0	21.46	95.3	25.38	102.0	27.68	106.9	28.85	109.3	29.77	111.7	30.56
	-2	68.9	17.89	82.0	21.69	95.3	25.63	102.0	27.83	106.9	29.19	109.3	30.02	111.7	30.67
	0	68.9	18.06	82.0	21.83	95.3	25.92	102.0	27.90	106.9	29.45	109.3	30.20	111.7	30.73
	2	68.9	18.10	82.0	22.06	95.3	26.11	102.0	28.17	106.9	29.56	109.3	30.42	111.7	30.79
	4	68.9	18.28	82.0	22.34	95.3	26.47	102.0	28.43	106.9	29.96	109.3	30.49	111.7	30.88
	6	68.9	18.48	82.0	22.51	95.3	26.79	102.0	28.74	106.9	30.28	109.3	30.74	111.7	30.97
	8	68.9	18.65	82.0	22.74	95.3	27.15	102.0	29.11	106.9	30.59	109.3	30.84	111.7	31.12
	10	68.9	18.87	82.0	23.04	95.3	27.40	102.0	29.64	106.9	30.61	109.3	30.93	111.7	31.26
	12	68.9	19.23	82.0	23.47	95.3	27.94	102.0	30.18	105.3	30.74	107.8	30.75	110.2	31.46
	14	68.9	19.60	82.0	23.95	95.3	28.49	102.0	30.79	103.8	30.93	106.5	31.22	109.0	31.84
	16	68.9	19.96	82.0	24.43	95.3	29.03	101.4	31.33	102.6	31.38	105.0	31.75	107.5	32.32
	18	68.9	20.32	82.0	24.92	95.3	30.00	99.9	32.06	101.1	32.17	103.5	32.48	106.2	32.78
	20	68.9	20.74	82.0	25.88	95.3	32.30	98.7	33.63	99.9	33.75	102.3	34.05	104.7	34.35
	21	68.9	20.93	82.0	26.79	95.3	33.45	97.7	34.41	99.0	34.53	101.7	34.84	104.1	35.20
	23	68.9	22.38	82.0	28.73	95.3	35.80	96.5	35.93	97.7	36.11	100.2	36.47	102.6	36.77
	25	68.9	23.89	82.0	30.72	93.8	37.38	95.0	37.50	96.2	37.68	99.0	38.04	101.4	38.40
	27	68.9	25.52	82.0	32.84	92.6	38.89	93.8	39.13	95.0	39.31	97.4	39.67	99.9	40.04
	29	68.9	27.22	82.0	35.08	91.1	40.46	92.3	40.70	93.5	40.88	95.9	41.31	98.7	41.67
	31	68.9	29.03	82.0	37.44	89.5	42.09	91.1	42.28	92.3	42.52	94.7	42.94	97.1	43.37
	33	68.9	30.90	82.0	39.92	88.3	43.67	89.6	43.91	90.8	44.09	93.2	44.58	95.6	45.00
	35	68.9	32.90	82.0	42.58	86.8	45.23	88.0	45.48	89.5	45.72	92.0	46.21	94.4	46.69
	37	68.9	35.02	82.0	45.36	85.6	46.87	86.8	47.11	88.0	47.36	90.5	47.84	92.9	48.38
	39	68.9	37.25	81.7	47.90	84.1	48.45	85.3	48.75	86.5	48.99	89.2	49.53	91.7	50.02
	41	68.9	38.28	81.0	48.24	83.4	48.79	84.6	49.09	85.9	49.33	88.6	49.67	89.0	50.39
43	68.9	38.85	80.6	48.58	82.8	49.08	84.0	49.27	85.2	49.51	87.0	49.81	87.7	51.40	
45	68.9	39.30	80.1	49.04	82.0	49.54	83.1	49.74	84.5	49.89	85.3	49.96	86.8	52.52	
48	68.9	39.57	79.4	49.58	80.9	49.98	81.8	50.03	83.5	50.35	84.0	50.48	85.6	53.17	

Abbreviations:

CR: Combination ratio

TC: Total capacity (kW)

PI: Power input (compressor + outdoor fan motor) (kW)

Notes:

Shaded cells indicate rating condition.

Table continued on next page ...

Table 2-8.12: 30HP cooling capacity (continued)

Combination (%) (Capacity index)	Outdoor temperature (°C DB)	Indoor temperature(°C DB/WB)													
		DB:20.8,WB:14		DB:23.3,WB:16		DB:25.8,WB:18		DB:27,WB:19		DB:28.2,WB:20		DB:30.7,WB:22		DB:32,WB:24	
		TC kW	PI kW	TC kW	PI kW	TC kW	PI kW	TC kW	PI kW	TC kW	PI kW	TC kW	PI kW	TC kW	PI kW
110%	-5	63.1	15.47	75.3	19.26	87.4	22.98	93.5	24.67	99.6	26.54	107.2	27.57	109.6	28.42
	-2	63.1	15.77	75.3	19.51	87.4	23.18	93.5	24.92	99.6	26.75	107.2	27.84	109.6	28.57
	0	63.1	15.93	75.3	19.62	87.4	23.35	93.5	25.08	99.6	27.05	107.2	28.12	109.6	28.92
	2	63.1	16.27	75.3	19.81	87.4	23.72	93.5	25.35	99.6	27.34	107.2	28.52	109.6	29.28
	4	63.1	16.60	75.3	20.03	87.4	23.95	93.5	25.66	99.6	27.75	107.2	28.92	109.6	29.55
	6	63.1	16.76	75.3	20.26	87.4	24.18	93.5	26.07	99.6	28.07	107.2	29.22	109.6	30.00
	8	63.1	16.92	75.3	20.58	87.4	24.45	93.5	26.34	99.6	28.39	107.2	29.42	109.6	30.32
	10	63.1	17.11	75.3	20.86	87.4	24.80	93.5	26.79	99.6	28.85	107.2	29.63	109.6	30.58
	12	63.1	17.48	75.3	21.29	87.4	25.28	93.5	27.34	99.6	29.39	106.0	30.06	108.1	30.98
	14	63.1	17.78	75.3	21.66	87.4	25.77	93.5	27.82	99.6	29.94	104.4	30.30	106.9	31.20
	16	63.1	18.09	75.3	22.08	87.4	26.25	93.5	28.36	99.6	30.54	103.2	30.66	105.3	31.54
	18	63.1	18.45	75.3	22.50	87.4	26.79	93.5	29.15	99.6	32.00	101.7	32.24	104.1	32.54
	20	63.1	18.81	75.3	22.98	87.4	28.36	93.5	31.33	98.1	33.57	100.5	33.81	102.6	34.11
	21	63.1	18.99	75.3	23.65	87.4	29.39	93.5	32.48	97.4	34.36	99.6	34.60	102.0	34.90
	23	63.1	19.90	75.3	25.34	87.4	31.51	93.5	34.84	95.9	35.86	98.4	36.22	100.5	36.53
	25	63.1	21.23	75.3	27.10	87.4	33.69	93.5	37.32	94.7	37.44	96.8	37.80	99.3	38.11
	27	63.1	22.62	75.3	28.97	87.4	36.05	92.0	38.89	93.2	39.01	95.6	39.38	97.8	39.74
	29	63.1	24.13	75.3	30.91	87.4	38.53	90.8	40.46	92.0	40.64	94.1	41.01	96.5	41.37
	31	63.1	25.70	75.3	32.96	87.4	41.13	89.3	42.04	90.5	42.22	92.9	42.58	95.0	43.00
	33	63.1	27.34	75.3	35.14	86.8	43.36	88.0	43.61	89.3	43.79	91.4	44.21	93.8	44.64
35	63.1	29.09	75.3	37.44	85.3	44.94	86.5	45.18	87.7	45.43	89.9	45.85	92.3	46.27	
37	63.1	30.97	75.3	39.86	84.1	46.57	85.3	46.75	86.2	47.00	88.6	47.48	90.8	47.90	
39	63.1	32.90	75.3	42.46	82.6	48.14	83.8	48.39	85.0	48.63	87.1	49.11	89.6	49.60	
41	63.1	33.24	75.3	42.80	81.9	48.48	83.1	48.73	84.4	48.97	86.0	49.45	86.9	49.93	
43	63.1	33.58	75.3	43.35	81.3	48.82	82.5	49.07	83.7	49.31	85.3	49.63	85.5	50.95	
45	63.1	34.67	75.3	43.59	80.5	49.27	81.6	49.66	83.0	49.76	84.4	50.99	84.7	52.13	
48	63.1	35.81	75.3	47.19	79.3	49.50	80.3	49.90	82.0	50.20	83.0	51.07	83.6	52.58	
100%	-5	57.4	14.09	68.3	16.96	79.5	20.19	85.0	21.63	90.5	23.47	101.7	26.75	107.5	27.91
	-2	57.4	14.26	68.3	17.19	79.5	20.42	85.0	22.03	90.5	23.78	101.7	27.06	107.5	28.09
	0	57.4	14.41	68.3	17.37	79.5	20.64	85.0	22.30	90.5	24.01	101.7	27.51	107.5	28.41
	2	57.4	14.69	68.3	17.60	79.5	20.87	85.0	22.60	90.5	24.28	101.7	27.91	107.5	28.86
	4	57.4	14.80	68.3	17.77	79.5	21.18	85.0	22.93	90.5	24.59	101.7	28.18	107.5	29.17
	6	57.4	15.01	68.3	18.13	79.5	21.45	85.0	23.34	90.5	24.95	101.7	28.59	107.5	29.62
	8	57.4	15.30	68.3	18.40	79.5	21.85	85.0	23.60	90.5	25.35	101.7	29.03	107.5	30.11
	10	57.4	15.48	68.3	18.75	79.5	22.20	85.0	24.01	90.5	25.83	101.7	29.51	107.5	30.54
	12	57.4	15.72	68.3	19.11	79.5	22.62	85.0	24.43	90.5	26.31	101.7	30.06	105.9	30.78
	14	57.4	16.03	68.3	19.48	79.5	23.04	85.0	24.92	90.5	26.79	101.7	30.66	104.7	31.15
	16	57.4	16.33	68.3	19.84	79.5	23.53	85.0	25.40	90.5	27.34	101.1	31.03	103.2	31.51
	18	57.4	16.63	68.3	20.20	79.5	23.95	85.0	25.88	90.5	27.88	99.9	32.05	102.0	32.30
	20	57.4	16.94	68.3	20.62	79.5	24.68	85.0	27.21	90.5	29.88	98.4	33.57	100.5	33.87
	21	57.4	17.12	68.3	20.80	79.5	25.58	85.0	28.18	90.5	30.91	97.8	34.35	99.9	34.65
	23	57.4	17.54	68.3	22.20	79.5	27.40	85.0	30.18	90.5	33.14	96.5	35.92	98.4	36.23
	25	57.4	18.69	68.3	23.71	79.5	29.33	85.0	32.36	90.5	35.50	95.0	37.50	97.1	37.80
	27	57.4	19.96	68.3	25.28	79.5	31.33	85.0	34.59	90.5	37.98	93.5	39.07	95.6	39.43
	29	57.4	21.23	68.3	26.97	79.5	33.45	85.0	36.96	90.2	40.34	92.3	40.70	94.4	41.00
	31	57.4	22.62	68.3	28.79	79.5	35.68	85.0	39.43	88.9	41.91	90.8	42.27	92.9	42.64
	33	57.4	24.01	68.3	30.66	79.5	38.04	85.0	42.09	87.4	43.48	89.6	43.85	91.7	44.27
35	57.4	25.52	68.3	32.60	79.5	40.58	85.0	44.88	85.9	45.06	88.0	45.48	90.2	45.85	
37	57.4	27.15	68.3	34.72	79.5	43.24	83.5	46.45	84.7	46.69	86.8	47.11	88.6	47.48	
39	57.4	28.85	68.3	36.89	79.5	46.02	82.3	48.02	83.2	48.26	85.3	48.69	87.4	49.17	
41	57.4	30.19	68.3	38.24	79.5	47.71	81.0	48.36	82.5	49.01	83.8	49.83	86.2	50.18	
43	57.4	31.54	68.3	39.59	79.5	48.59	79.7	48.92	81.9	49.48	84.3	50.16	84.6	50.74	
45	57.4	33.33	68.3	41.38	79.5	49.42	78.0	49.59	81.5	50.38	83.6	50.93	82.9	51.41	
48	57.4	34.80	68.3	42.83	79.5	49.50	74.8	50.16	81.4	51.27	78.5	51.46	81.1	51.89	

Abbreviations:

CR: Combination ratio

TC: Total capacity (kW)

PI: Power input (compressor + outdoor fan motor) (kW)

Notes:

Shaded cells indicate rating condition.

Table continued on next page ...

Table 2-8.12: 30HP cooling capacity (continued)

Combination (%) (Capacity index)	Outdoor temperature (°C DB)	Indoor temperature(°C DB/WB)													
		DB:20.8,WB:14		DB:23.3,WB:16		DB:25.8,WB:18		DB:27,WB:19		DB:28.2,WB:20		DB:30.7,WB:22		DB:32,WB:24	
		TC kW	PI kW	TC kW	PI kW	TC kW	PI kW	TC kW	PI kW	TC kW	PI kW	TC kW	PI kW	TC kW	PI kW
90%	-5	51.6	12.46	61.6	14.95	71.6	17.64	76.5	19.25	81.4	20.47	91.4	23.54	101.4	26.96
	-2	51.6	12.58	61.6	15.11	71.6	17.87	76.5	19.52	81.4	20.72	91.4	23.77	101.4	27.22
	0	51.6	12.77	61.6	15.30	71.6	18.14	76.5	19.75	81.4	20.99	91.4	24.04	101.4	27.43
	2	51.6	12.96	61.6	15.49	71.6	18.33	76.5	20.05	81.4	21.32	91.4	24.54	101.4	27.84
	4	51.6	13.16	61.6	15.72	71.6	18.63	76.5	20.32	81.4	21.59	91.4	24.92	101.4	28.24
	6	51.6	13.34	61.6	16.03	71.6	18.98	76.5	20.70	81.4	21.97	91.4	25.31	101.4	28.72
	8	51.6	13.59	61.6	16.33	71.6	19.37	76.5	20.97	81.4	22.35	91.4	25.78	101.4	28.99
	10	51.6	13.85	61.6	16.69	71.6	19.72	76.5	21.29	81.4	22.86	91.4	26.11	101.4	29.45
	12	51.6	14.09	61.6	16.99	71.6	20.08	76.5	21.64	81.4	23.29	91.4	26.61	101.4	29.99
	14	51.6	14.33	61.6	17.30	71.6	20.44	76.5	22.07	81.4	23.71	91.4	27.09	101.4	30.54
	16	51.6	14.57	61.6	17.60	71.6	20.87	76.5	22.50	81.4	24.19	91.4	27.64	101.1	31.08
	18	51.6	14.82	61.6	17.96	71.6	21.23	76.5	22.92	81.4	24.67	91.4	28.18	99.9	32.05
	20	51.6	15.12	61.6	18.37	71.6	21.65	76.5	23.40	81.4	25.58	91.4	30.30	98.4	33.56
	21	51.6	15.24	61.6	18.50	71.6	22.01	76.5	24.19	81.4	26.49	91.4	31.39	97.8	34.35
	23	51.6	15.54	61.6	19.23	71.6	23.58	76.5	25.95	81.4	28.42	91.4	33.68	96.2	35.92
	25	51.6	16.39	61.6	20.56	71.6	25.22	76.5	27.76	81.4	30.36	91.4	36.05	95.0	37.49
	27	51.6	17.42	61.6	21.89	71.6	26.91	76.5	29.63	81.4	32.48	91.4	38.58	93.5	39.07
	29	51.6	18.57	61.6	23.34	71.6	28.73	76.5	31.63	81.4	34.71	90.5	40.34	92.3	40.64
	31	51.6	19.72	61.6	24.86	71.6	30.60	76.5	33.74	81.4	37.01	88.9	41.91	90.8	42.27
	33	51.6	20.92	61.6	26.43	71.6	32.66	76.5	35.98	81.4	39.49	87.7	43.54	89.6	43.84
35	51.6	22.25	61.6	28.12	71.6	34.77	76.5	38.34	81.4	42.09	86.2	45.12	88.0	45.48	
37	51.6	23.58	61.6	29.88	71.6	37.01	76.5	40.82	81.4	44.87	84.7	46.69	86.8	47.05	
39	51.6	25.04	61.6	31.81	71.6	39.37	76.5	43.48	81.4	47.78	83.5	48.32	85.3	48.68	
41	51.6	25.90	61.6	33.25	71.6	40.81	76.5	44.63	81.4	48.07	82.9	49.55	84.7	49.83	
43	51.6	27.15	61.6	34.69	71.6	42.25	76.5	45.78	81.4	49.09	82.5	50.20	84.0	50.61	
45	51.6	28.87	61.6	36.41	71.6	43.97	76.5	47.32	81.4	50.45	82.0	50.72	82.7	51.28	
48	51.6	30.47	61.6	38.09	71.6	45.63	76.5	47.92	81.4	50.88	81.3	51.43	80.5	51.97	
80%	-5	45.8	10.98	54.6	12.98	63.4	15.37	68.0	16.34	72.6	17.60	81.4	20.35	90.2	23.22
	-2	45.8	11.14	54.6	13.14	63.4	15.50	68.0	16.60	72.6	17.76	81.4	20.54	90.2	23.45
	0	45.8	11.34	54.6	13.31	63.4	15.70	68.0	16.79	72.6	18.09	81.4	20.83	90.2	23.77
	2	45.8	11.56	54.6	13.50	63.4	15.92	68.0	17.12	72.6	18.41	81.4	21.25	90.2	24.22
	4	45.8	11.76	54.6	13.73	63.4	16.22	68.0	17.51	72.6	18.73	81.4	21.64	90.2	24.55
	6	45.8	11.95	54.6	14.05	63.4	16.47	68.0	17.89	72.6	19.09	81.4	21.96	90.2	24.97
	8	45.8	12.18	54.6	14.37	63.4	16.86	68.0	18.18	72.6	19.51	81.4	22.29	90.2	25.45
	10	45.8	12.28	54.6	14.70	63.4	17.30	68.0	18.63	72.6	19.96	81.4	22.80	90.2	25.71
	12	45.8	12.46	54.6	14.94	63.4	17.60	68.0	18.99	72.6	20.38	81.4	23.22	90.2	26.19
	14	45.8	12.70	54.6	15.24	63.4	17.90	68.0	19.29	72.6	20.74	81.4	23.65	90.2	26.67
	16	45.8	12.88	54.6	15.48	63.4	18.26	68.0	19.66	72.6	21.11	81.4	24.13	90.2	27.16
	18	45.8	13.13	54.6	15.79	63.4	18.63	68.0	20.08	72.6	21.53	81.4	24.62	90.2	27.70
	20	45.8	13.37	54.6	16.09	63.4	18.99	68.0	20.44	72.6	21.96	81.4	25.52	90.2	29.64
	21	45.8	13.49	54.6	16.21	63.4	19.17	68.0	20.68	72.6	22.44	81.4	26.43	90.2	30.72
	23	45.8	13.73	54.6	16.57	63.4	20.08	68.0	22.01	72.6	24.01	81.4	28.31	90.2	32.96
	25	45.8	14.15	54.6	17.60	63.4	21.47	68.0	23.53	72.6	25.64	81.4	30.30	90.2	35.26
	27	45.8	15.06	54.6	18.75	63.4	22.86	68.0	25.10	72.6	27.40	81.4	32.36	90.2	37.74
	29	45.8	16.03	54.6	19.96	63.4	24.37	68.0	26.73	72.6	29.27	81.4	34.54	90.2	40.34
	31	45.8	16.99	54.6	21.23	63.4	25.95	68.0	28.49	72.6	31.21	81.4	36.89	88.6	41.92
	33	45.8	18.08	54.6	22.56	63.4	27.64	68.0	30.36	72.6	33.20	81.4	39.31	87.4	43.48
35	45.8	19.17	54.6	24.01	63.4	29.39	68.0	32.30	72.6	35.38	81.4	41.92	85.9	45.06	
37	45.8	20.32	54.6	25.46	63.4	31.27	68.0	34.41	72.6	37.68	81.4	44.70	84.7	46.63	
39	45.8	21.53	54.6	27.16	63.4	33.27	68.0	36.59	72.6	40.10	81.4	47.60	83.2	48.26	
41	45.8	22.02	54.6	27.40	63.4	33.75	68.0	37.56	72.6	40.83	81.4	48.81	82.7	49.11	
43	45.8	22.66	54.6	27.64	63.4	34.24	68.0	38.21	72.6	41.39	81.4	49.38	82.2	49.64	
45	45.8	23.31	54.6	27.96	63.4	34.90	68.0	39.01	72.6	42.11	81.4	49.92	81.1	50.45	
48	45.8	24.06	54.6	28.13	63.4	35.43	68.0	39.53	72.6	42.44	81.4	50.38	80.5	51.09	

Abbreviations:

CR: Combination ratio

TC: Total capacity (kW)

PI: Power input (compressor + outdoor fan motor) (kW)

Notes:

Shaded cells indicate rating condition.

Table continued on next page ...

Table 2-8.12: 30HP cooling capacity (continued)

Combination (%) (Capacity index)	Outdoor temperature (°C DB)	Indoor temperature(°C DB/WB)													
		DB:20.8,WB:14		DB:23.3,WB:16		DB:25.8,WB:18		DB:27,WB:19		DB:28.2,WB:20		DB:30.7,WB:22		DB:32,WB:24	
		TC	PI	TC	PI	TC	PI	TC	PI	TC	PI	TC	PI	TC	PI
70%	-5	40.1	9.80	48.0	11.49	55.6	13.02	59.5	13.96	63.4	14.90	71.0	17.05	78.9	19.60
	-2	40.1	9.88	48.0	11.55	55.6	13.10	59.5	14.23	63.4	15.17	71.0	17.32	78.9	19.87
	0	40.1	9.94	48.0	11.71	55.6	13.37	59.5	14.50	63.4	15.44	71.0	17.67	78.9	20.14
	2	40.1	9.99	48.0	11.76	55.6	13.59	59.5	14.77	63.4	15.71	71.0	18.05	78.9	20.46
	4	40.1	10.12	48.0	12.06	55.6	13.89	59.5	15.04	63.4	16.06	71.0	18.34	78.9	20.95
	6	40.1	10.28	48.0	12.27	55.6	14.23	59.5	15.52	63.4	16.43	71.0	18.66	78.9	21.35
	8	40.1	10.47	48.0	12.62	55.6	14.55	59.5	15.76	63.4	16.78	71.0	19.20	78.9	21.75
	10	40.1	10.69	48.0	12.82	55.6	14.94	59.5	16.09	63.4	17.24	71.0	19.60	78.9	22.01
	12	40.1	10.95	48.0	13.00	55.6	15.24	59.5	16.39	63.4	17.54	71.0	19.96	78.9	22.44
	14	40.1	11.13	48.0	13.24	55.6	15.48	59.5	16.63	63.4	17.84	71.0	20.32	78.9	22.86
	16	40.1	11.31	48.0	13.49	55.6	15.78	59.5	17.00	63.4	18.20	71.0	20.69	78.9	23.28
	18	40.1	11.49	48.0	13.73	55.6	16.09	59.5	17.30	63.4	18.51	71.0	21.11	78.9	23.77
	20	40.1	11.67	48.0	13.97	55.6	16.39	59.5	17.60	63.4	18.87	71.0	21.53	78.9	24.43
	21	40.1	11.79	48.0	14.09	55.6	16.51	59.5	17.78	63.4	19.05	71.0	21.83	78.9	25.28
	23	40.1	11.97	48.0	14.33	55.6	16.87	59.5	18.39	63.4	20.02	71.0	23.41	78.9	27.10
	25	40.1	12.22	48.0	14.94	55.6	17.96	59.5	19.66	63.4	21.35	71.0	25.04	78.9	28.97
	27	40.1	12.94	48.0	15.91	55.6	19.17	59.5	20.93	63.4	22.80	71.0	26.73	78.9	30.97
	29	40.1	13.73	48.0	16.87	55.6	20.38	59.5	22.32	63.4	24.25	71.0	28.49	78.9	33.08
	31	40.1	14.51	48.0	17.90	55.6	21.71	59.5	23.71	63.4	25.83	71.0	30.36	78.9	35.26
	33	40.1	15.42	48.0	19.05	55.6	23.10	59.5	25.22	63.4	27.52	71.0	32.36	78.9	37.62
35	40.1	16.33	48.0	20.20	55.6	24.50	59.5	26.85	63.4	29.27	71.0	34.47	78.9	40.10	
37	40.1	17.24	48.0	21.41	55.6	26.07	59.5	28.49	63.4	31.15	71.0	36.71	78.9	42.70	
39	40.1	18.27	48.0	22.68	55.6	27.64	59.5	30.30	63.4	33.08	71.0	39.01	78.9	45.48	
41	40.1	19.07	48.0	23.49	55.6	28.45	59.5	31.31	63.4	34.09	71.0	40.62	78.9	47.50	
43	40.1	20.62	48.0	25.10	55.6	29.62	59.5	32.99	63.4	35.10	71.0	42.10	78.9	48.97	
45	40.1	21.08	48.0	25.63	55.6	30.24	59.5	33.52	63.4	36.84	71.0	44.38	78.9	50.85	
48	40.1	21.48	48.0	25.78	55.6	30.61	59.5	34.10	63.4	37.86	71.0	46.46	78.9	52.10	
60%	-5	34.3	8.36	41.0	9.70	47.7	11.30	51.0	12.04	54.3	13.00	61.0	14.60	67.7	16.75
	-2	34.3	8.41	41.0	9.85	47.7	11.51	51.0	12.21	54.3	13.13	61.0	14.82	67.7	16.86
	0	34.3	8.54	41.0	9.97	47.7	11.66	51.0	12.37	54.3	13.35	61.0	15.04	67.7	17.07
	2	34.3	8.69	41.0	10.20	47.7	11.88	51.0	12.61	54.3	13.53	61.0	15.35	67.7	17.29
	4	34.3	8.93	41.0	10.40	47.7	12.11	51.0	12.76	54.3	13.73	61.0	15.59	67.7	17.54
	6	34.3	9.02	41.0	10.59	47.7	12.34	51.0	13.05	54.3	14.01	61.0	15.90	67.7	17.95
	8	34.3	9.19	41.0	10.77	47.7	12.57	51.0	13.29	54.3	14.29	61.0	16.20	67.7	18.23
	10	34.3	9.37	41.0	11.01	47.7	12.76	51.0	13.67	54.3	14.57	61.0	16.51	67.7	18.50
	12	34.3	9.56	41.0	11.19	47.7	13.00	51.0	13.91	54.3	14.82	61.0	16.81	67.7	18.81
	14	34.3	9.68	41.0	11.37	47.7	13.18	51.0	14.15	54.3	15.12	61.0	17.11	67.7	19.17
	16	34.3	9.80	41.0	11.55	47.7	13.43	51.0	14.39	54.3	15.36	61.0	17.42	67.7	19.53
	18	34.3	9.98	41.0	11.73	47.7	13.67	51.0	14.63	54.3	15.66	61.0	17.72	67.7	19.89
	20	34.3	10.10	41.0	11.97	47.7	13.91	51.0	14.94	54.3	15.96	61.0	18.08	67.7	20.32
	21	34.3	10.22	41.0	12.03	47.7	14.03	51.0	15.06	54.3	16.09	61.0	18.26	67.7	20.50
	23	34.3	10.34	41.0	12.28	47.7	14.27	51.0	15.36	54.3	16.39	61.0	18.99	67.7	21.83
	25	34.3	10.52	41.0	12.46	47.7	14.82	51.0	16.09	54.3	17.42	61.0	20.26	67.7	23.28
	27	34.3	10.95	41.0	13.24	47.7	15.78	51.0	17.17	54.3	18.57	61.0	21.59	67.7	24.85
	29	34.3	11.55	41.0	14.03	47.7	16.81	51.0	18.26	54.3	19.77	61.0	23.04	67.7	26.55
	31	34.3	12.28	41.0	14.88	47.7	17.84	51.0	19.41	54.3	21.04	61.0	24.49	67.7	28.24
	33	34.3	12.94	41.0	15.78	47.7	18.93	51.0	20.62	54.3	22.37	61.0	26.06	67.7	30.11
35	34.3	13.73	41.0	16.75	47.7	20.08	51.0	21.89	54.3	23.76	61.0	27.76	67.7	32.05	
37	34.3	14.51	41.0	17.72	47.7	21.29	51.0	23.22	54.3	25.22	61.0	29.51	67.7	34.11	
39	34.3	15.30	41.0	18.75	47.7	22.56	51.0	24.61	54.3	26.79	61.0	31.32	67.7	36.28	
41	34.3	15.79	41.0	19.56	47.7	23.38	51.0	25.60	54.3	27.77	61.0	32.80	67.7	37.93	
43	34.3	16.28	41.0	20.38	47.7	24.20	51.0	26.36	54.3	28.74	61.0	34.19	67.7	39.57	
45	34.3	17.05	41.0	21.41	47.7	25.18	51.0	27.35	54.3	30.17	61.0	35.73	67.7	41.76	
48	34.3	17.69	41.0	22.33	47.7	26.05	51.0	28.02	54.3	31.30	61.0	36.99	67.7	43.78	

Abbreviations:

CR: Combination ratio

TC: Total capacity (kW)

PI: Power input (compressor + outdoor fan motor) (kW)

Notes:

Shaded cells indicate rating condition.

Table continued on next page ...

Table 2-8.12: 30HP cooling capacity (continued)

Combination (%) (Capacity index)	Outdoor temperature (°C DB)	Indoor temperature(°C DB/WB)													
		DB:20.8,WB:14		DB:23.3,WB:16		DB:25.8,WB:18		DB:27,WB:19		DB:28.2,WB:20		DB:30.7,WB:22		DB:32,WB:24	
		TC	PI	TC	PI	TC	PI	TC	PI	TC	PI	TC	PI	TC	PI
50%	-5	28.7	7.26	34.3	8.40	39.8	9.65	42.5	10.10	45.2	10.66	50.7	12.12	56.5	13.06
	-2	28.7	7.31	34.3	8.57	39.8	9.75	42.5	10.24	45.2	10.85	50.7	12.28	56.5	13.24
	0	28.7	7.44	34.3	8.71	39.8	9.93	42.5	10.38	45.2	10.97	50.7	12.49	56.5	13.46
	2	28.7	7.54	34.3	8.81	39.8	10.10	42.5	10.54	45.2	11.16	50.7	12.54	56.5	13.72
	4	28.7	7.62	34.3	8.97	39.8	10.21	42.5	10.66	45.2	11.39	50.7	12.85	56.5	14.07
	6	28.7	7.76	34.3	9.11	39.8	10.36	42.5	10.90	45.2	11.60	50.7	13.05	56.5	14.49
	8	28.7	7.94	34.3	9.27	39.8	10.54	42.5	11.15	45.2	11.76	50.7	13.26	56.5	14.96
	10	28.7	8.10	34.3	9.37	39.8	10.70	42.5	11.32	45.2	12.09	50.7	13.61	56.5	15.18
	12	28.7	8.16	34.3	9.49	39.8	10.89	42.5	11.55	45.2	12.34	50.7	13.85	56.5	15.42
	14	28.7	8.28	34.3	9.62	39.8	11.01	42.5	11.79	45.2	12.52	50.7	14.09	56.5	15.72
	16	28.7	8.41	34.3	9.74	39.8	11.19	42.5	11.97	45.2	12.70	50.7	14.33	56.5	15.97
	18	28.7	8.53	34.3	9.92	39.8	11.37	42.5	12.15	45.2	12.94	50.7	14.57	56.5	16.27
	20	28.7	8.65	34.3	10.04	39.8	11.55	42.5	12.34	45.2	13.18	50.7	14.82	56.5	16.57
	21	28.7	8.71	34.3	10.16	39.8	11.67	42.5	12.46	45.2	13.30	50.7	15.00	56.5	16.75
	23	28.7	8.83	34.3	10.28	39.8	11.85	42.5	12.70	45.2	13.55	50.7	15.24	56.5	17.11
	25	28.7	8.95	34.3	10.46	39.8	12.09	42.5	12.94	45.2	13.97	50.7	16.02	56.5	18.26
	27	28.7	9.13	34.3	10.89	39.8	12.76	42.5	13.79	45.2	14.82	50.7	17.05	56.5	19.47
	29	28.7	9.62	34.3	11.49	39.8	13.55	42.5	14.63	45.2	15.78	50.7	18.14	56.5	20.74
	31	28.7	10.16	34.3	12.15	39.8	14.33	42.5	15.54	45.2	16.75	50.7	19.29	56.5	22.07
	33	28.7	10.77	34.3	12.88	39.8	15.24	42.5	16.45	45.2	17.78	50.7	20.50	56.5	23.46
35	28.7	11.37	34.3	13.61	39.8	16.09	42.5	17.42	45.2	18.81	50.7	21.77	56.5	24.92	
37	28.7	11.97	34.3	14.39	39.8	17.05	42.5	18.44	45.2	19.96	50.7	23.10	56.5	26.49	
39	28.7	12.64	34.3	15.18	39.8	18.02	42.5	19.53	45.2	21.17	50.7	24.49	56.5	28.12	
41	28.7	13.16	34.3	15.83	39.8	18.67	42.5	20.45	45.2	22.08	50.7	25.80	56.5	29.43	
43	28.7	14.03	34.3	16.92	39.8	19.33	42.5	21.36	45.2	22.65	50.7	27.11	56.5	30.73	
45	28.7	14.35	34.3	17.36	39.8	20.63	42.5	23.02	45.2	23.60	50.7	29.72	56.5	33.35	
48	28.7	14.63	34.3	17.76	39.8	21.77	42.5	24.56	45.2	24.73	50.7	32.05	56.5	35.88	

Abbreviations:

CR: Combination ratio

TC: Total capacity (kW)

PI: Power input (compressor + outdoor fan motor) (kW)

Notes:

Shaded cells indicate rating condition.

Table 2-8.13: 32HP cooling capacity

Combination (%) (Capacity index)	Outdoor temperature (°C DB)	Indoor temperature(°C DB/WB)													
		DB:20.8,WB:14		DB:23.3,WB:16		DB:25.8,WB:18		DB:27,WB:19		DB:28.2,WB:20		DB:30.7,WB:22		DB:32,WB:24	
		TC	PI	TC	PI	TC	PI	TC	PI	TC	PI	TC	PI	TC	PI
130%	-5	74.7	18.34	88.9	22.39	103.2	24.00	107.2	24.98	112.3	25.69	115.0	27.93	117.9	28.11
	-2	74.7	18.34	88.9	22.82	103.2	24.00	107.2	25.12	112.3	25.69	115.0	28.29	117.9	28.39
	0	74.7	18.66	88.9	23.22	103.2	24.88	107.2	26.50	112.3	27.18	115.0	28.63	117.9	28.77
	2	74.7	18.99	88.9	23.27	103.2	25.73	107.2	27.99	112.3	27.49	115.0	28.84	117.9	29.19
	4	74.7	19.42	88.9	23.72	103.2	26.62	107.2	28.11	112.3	27.85	115.0	29.28	117.9	29.75
	6	74.7	19.79	88.9	24.19	103.2	27.60	107.2	28.35	111.1	28.71	113.6	29.73	116.6	29.97
	8	74.7	20.27	88.9	24.75	103.2	28.99	107.2	29.73	109.7	29.65	112.4	29.83	115.2	30.26
	10	74.7	20.69	88.9	25.28	103.2	30.06	107.2	30.73	108.4	30.20	111.1	30.28	113.8	31.14
	12	74.7	21.05	88.9	25.76	103.2	30.66	105.6	31.19	107.2	30.66	109.6	30.74	112.3	31.33
	14	74.7	21.47	88.9	26.25	102.9	31.12	104.4	31.64	105.6	31.12	108.4	31.20	111.1	32.04
	16	74.7	21.84	88.9	26.79	101.7	31.58	102.9	32.06	104.1	32.03	106.9	31.66	109.6	32.55
	18	74.7	22.26	88.9	27.34	100.2	32.06	101.4	32.24	102.9	32.42	105.6	32.72	108.4	33.03
	20	74.7	22.74	88.9	29.09	98.7	33.63	100.2	33.81	101.4	33.99	104.1	34.29	106.9	34.66
	21	74.7	23.35	88.9	30.12	98.0	34.42	99.6	34.60	100.8	34.78	103.5	35.14	106.2	35.44
	23	74.7	25.04	88.9	32.30	96.8	35.99	98.0	36.17	99.3	36.35	102.0	36.71	104.7	37.08
	25	74.7	26.73	88.9	34.60	95.3	37.56	96.5	37.74	98.0	37.98	100.8	38.35	103.5	38.71
	27	74.7	28.55	88.9	37.02	94.1	39.13	95.3	39.37	96.5	39.56	99.3	39.98	102.0	40.40
	29	74.7	30.48	88.9	39.56	92.6	40.70	93.8	40.95	95.3	41.19	98.0	41.62	100.8	42.04
	31	74.7	32.54	88.6	41.85	91.1	42.34	92.6	42.58	93.8	42.76	96.5	43.25	99.3	43.73
	33	74.7	34.66	87.1	43.43	89.9	43.91	91.1	44.15	92.6	44.39	95.3	44.88	97.7	45.37
35	74.7	36.95	85.6	45.00	88.3	45.54	89.9	45.79	91.1	46.03	93.8	46.57	96.5	47.06	
37	74.7	39.32	84.4	46.63	87.1	47.18	88.3	47.42	89.9	47.72	92.3	48.27	95.0	48.81	
39	74.7	41.85	82.9	47.12	85.6	48.75	87.1	49.05	88.3	49.35	91.1	49.90	93.8	50.50	
41	74.7	44.05	82.0	47.58	84.7	49.21	86.2	49.51	87.4	49.81	90.2	50.00	90.2	50.96	
43	74.7	45.17	81.4	47.81	84.3	49.34	85.8	49.74	86.5	49.88	88.5	50.09	89.1	51.08	
45	74.7	47.41	80.9	48.26	83.4	49.80	84.9	50.06	85.3	50.11	86.1	50.27	87.4	52.04	
48	74.7	49.05	80.6	49.80	82.0	50.22	83.5	50.47	84.2	50.64	83.8	51.14	85.4	52.23	
120%	-5	68.9	17.72	82.0	21.46	95.3	25.38	102.0	27.68	106.9	28.85	109.3	29.77	111.7	30.56
	-2	68.9	17.89	82.0	21.69	95.3	25.63	102.0	27.83	106.9	29.19	109.3	30.02	111.7	30.67
	0	68.9	18.06	82.0	21.83	95.3	25.92	102.0	27.90	106.9	29.45	109.3	30.20	111.7	30.73
	2	68.9	18.10	82.0	22.06	95.3	26.11	102.0	28.17	106.9	29.56	109.3	30.42	111.7	30.79
	4	68.9	18.28	82.0	22.34	95.3	26.47	102.0	28.43	106.9	29.96	109.3	30.49	111.7	30.88
	6	68.9	18.48	82.0	22.51	95.3	26.79	102.0	28.74	106.9	30.28	109.3	30.74	111.7	30.97
	8	68.9	18.65	82.0	22.74	95.3	27.15	102.0	29.11	106.9	30.59	109.3	30.84	111.7	31.12
	10	68.9	18.87	82.0	23.04	95.3	27.40	102.0	29.64	106.9	30.61	109.3	30.93	111.7	31.26
	12	68.9	19.23	82.0	23.47	95.3	27.94	102.0	30.18	105.3	30.74	107.8	30.75	110.2	31.46
	14	68.9	19.60	82.0	23.95	95.3	28.49	102.0	30.79	103.8	30.93	106.5	31.22	109.0	31.84
	16	68.9	19.96	82.0	24.43	95.3	29.03	101.4	31.33	102.6	31.38	105.0	31.75	107.5	32.32
	18	68.9	20.32	82.0	24.92	95.3	30.00	99.9	32.06	101.1	32.17	103.5	32.48	106.2	32.78
	20	68.9	20.74	82.0	25.88	95.3	32.30	98.7	33.63	99.9	33.75	102.3	34.05	104.7	34.35
	21	68.9	20.93	82.0	26.79	95.3	33.45	97.7	34.41	99.0	34.53	101.7	34.84	104.1	35.20
	23	68.9	22.38	82.0	28.73	95.3	35.80	96.5	35.93	97.7	36.11	100.2	36.47	102.6	36.77
	25	68.9	23.89	82.0	30.72	93.8	37.38	95.0	37.50	96.2	37.68	99.0	38.04	101.4	38.40
	27	68.9	25.52	82.0	32.84	92.6	38.89	93.8	39.13	95.0	39.31	97.4	39.67	99.9	40.04
	29	68.9	27.22	82.0	35.08	91.1	40.46	92.3	40.70	93.5	40.88	95.9	41.31	98.7	41.67
	31	68.9	29.03	82.0	37.44	89.5	42.09	91.1	42.28	92.3	42.52	94.7	42.94	97.1	43.37
	33	68.9	30.90	82.0	39.92	88.3	43.67	89.6	43.91	90.8	44.09	93.2	44.58	95.6	45.00
35	68.9	32.90	82.0	42.58	86.8	45.23	88.0	45.48	89.5	45.72	92.0	46.21	94.4	46.69	
37	68.9	35.02	82.0	45.36	85.6	46.87	86.8	47.11	88.0	47.36	90.5	47.84	92.9	48.38	
39	68.9	37.25	81.7	47.90	84.1	48.45	85.3	48.75	86.5	48.99	89.2	49.53	91.7	50.02	
41	68.9	38.28	81.0	48.24	83.4	48.79	84.6	49.09	85.9	49.33	88.6	49.67	89.0	50.39	
43	68.9	38.85	80.6	48.58	82.8	49.08	84.0	49.27	85.2	49.51	87.0	49.81	87.7	51.40	
45	68.9	39.30	80.1	49.04	82.0	49.54	83.1	49.74	84.5	49.89	85.3	49.96	86.8	52.52	
48	68.9	39.57	79.4	49.58	80.9	49.98	81.8	50.03	83.5	50.35	84.0	50.48	85.6	53.17	

Abbreviations:
 CR: Combination ratio
 TC: Total capacity (kW)
 PI: Power input (compressor + outdoor fan motor) (kW)

Notes:
 Shaded cells indicate rating condition.

Table continued on next page ...

Table 2-8.13: 32HP cooling capacity (continued)

Combination (%) (Capacity index)	Outdoor temperature (°C DB)	Indoor temperature(°C DB/WB)													
		DB:20.8,WB:14		DB:23.3,WB:16		DB:25.8,WB:18		DB:27,WB:19		DB:28.2,WB:20		DB:30.7,WB:22		DB:32,WB:24	
		TC kW	PI kW	TC kW	PI kW	TC kW	PI kW	TC kW	PI kW	TC kW	PI kW	TC kW	PI kW	TC kW	PI kW
110%	-5	63.1	15.47	75.3	19.26	87.4	22.98	93.5	24.67	99.6	26.54	107.2	27.57	109.6	28.42
	-2	63.1	15.77	75.3	19.51	87.4	23.18	93.5	24.92	99.6	26.75	107.2	27.84	109.6	28.57
	0	63.1	15.93	75.3	19.62	87.4	23.35	93.5	25.08	99.6	27.05	107.2	28.12	109.6	28.92
	2	63.1	16.27	75.3	19.81	87.4	23.72	93.5	25.35	99.6	27.34	107.2	28.52	109.6	29.28
	4	63.1	16.60	75.3	20.03	87.4	23.95	93.5	25.66	99.6	27.75	107.2	28.92	109.6	29.55
	6	63.1	16.76	75.3	20.26	87.4	24.18	93.5	26.07	99.6	28.07	107.2	29.22	109.6	30.00
	8	63.1	16.92	75.3	20.58	87.4	24.45	93.5	26.34	99.6	28.39	107.2	29.42	109.6	30.32
	10	63.1	17.11	75.3	20.86	87.4	24.80	93.5	26.79	99.6	28.85	107.2	29.63	109.6	30.58
	12	63.1	17.48	75.3	21.29	87.4	25.28	93.5	27.34	99.6	29.39	106.0	30.06	108.1	30.98
	14	63.1	17.78	75.3	21.66	87.4	25.77	93.5	27.82	99.6	29.94	104.4	30.30	106.9	31.20
	16	63.1	18.09	75.3	22.08	87.4	26.25	93.5	28.36	99.6	30.54	103.2	30.66	105.3	31.54
	18	63.1	18.45	75.3	22.50	87.4	26.79	93.5	29.15	99.6	32.00	101.7	32.24	104.1	32.54
	20	63.1	18.81	75.3	22.98	87.4	28.36	93.5	31.33	98.1	33.57	100.5	33.81	102.6	34.11
	21	63.1	18.99	75.3	23.65	87.4	29.39	93.5	32.48	97.4	34.36	99.6	34.60	102.0	34.90
	23	63.1	19.90	75.3	25.34	87.4	31.51	93.5	34.84	95.9	35.86	98.4	36.22	100.5	36.53
	25	63.1	21.23	75.3	27.10	87.4	33.69	93.5	37.32	94.7	37.44	96.8	37.80	99.3	38.11
	27	63.1	22.62	75.3	28.97	87.4	36.05	92.0	38.89	93.2	39.01	95.6	39.38	97.8	39.74
	29	63.1	24.13	75.3	30.91	87.4	38.53	90.8	40.46	92.0	40.64	94.1	41.01	96.5	41.37
	31	63.1	25.70	75.3	32.96	87.4	41.13	89.3	42.04	90.5	42.22	92.9	42.58	95.0	43.00
	33	63.1	27.34	75.3	35.14	86.8	43.36	88.0	43.61	89.3	43.79	91.4	44.21	93.8	44.64
35	63.1	29.09	75.3	37.44	85.3	44.94	86.5	45.18	87.7	45.43	89.9	45.85	92.3	46.27	
37	63.1	30.97	75.3	39.86	84.1	46.57	85.3	46.75	86.2	47.00	88.6	47.48	90.8	47.90	
39	63.1	32.90	75.3	42.46	82.6	48.14	83.8	48.39	85.0	48.63	87.1	49.11	89.6	49.60	
41	63.1	33.24	75.3	42.80	81.9	48.48	83.1	48.73	84.4	48.97	86.0	49.45	86.9	49.93	
43	63.1	33.58	75.3	43.35	81.3	48.82	82.5	49.07	83.7	49.31	85.3	49.63	85.5	50.95	
45	63.1	34.67	75.3	43.59	80.5	49.27	81.6	49.66	83.0	49.76	84.4	50.99	84.7	52.13	
48	63.1	35.81	75.3	47.19	79.3	49.50	80.3	49.90	82.0	50.20	83.0	51.07	83.6	52.58	
100%	-5	57.4	14.09	68.3	16.96	79.5	20.19	85.0	21.63	90.5	23.47	101.7	26.75	107.5	27.91
	-2	57.4	14.26	68.3	17.19	79.5	20.42	85.0	22.03	90.5	23.78	101.7	27.06	107.5	28.09
	0	57.4	14.41	68.3	17.37	79.5	20.64	85.0	22.30	90.5	24.01	101.7	27.51	107.5	28.41
	2	57.4	14.69	68.3	17.60	79.5	20.87	85.0	22.60	90.5	24.28	101.7	27.91	107.5	28.86
	4	57.4	14.80	68.3	17.77	79.5	21.18	85.0	22.93	90.5	24.59	101.7	28.18	107.5	29.17
	6	57.4	15.01	68.3	18.13	79.5	21.45	85.0	23.34	90.5	24.95	101.7	28.59	107.5	29.62
	8	57.4	15.30	68.3	18.40	79.5	21.85	85.0	23.60	90.5	25.35	101.7	29.03	107.5	30.11
	10	57.4	15.48	68.3	18.75	79.5	22.20	85.0	24.01	90.5	25.83	101.7	29.51	107.5	30.54
	12	57.4	15.72	68.3	19.11	79.5	22.62	85.0	24.43	90.5	26.31	101.7	30.06	105.9	30.78
	14	57.4	16.03	68.3	19.48	79.5	23.04	85.0	24.92	90.5	26.79	101.7	30.66	104.7	31.15
	16	57.4	16.33	68.3	19.84	79.5	23.53	85.0	25.40	90.5	27.34	101.1	31.03	103.2	31.51
	18	57.4	16.63	68.3	20.20	79.5	23.95	85.0	25.88	90.5	27.88	99.9	32.05	102.0	32.30
	20	57.4	16.94	68.3	20.62	79.5	24.68	85.0	27.21	90.5	29.88	98.4	33.57	100.5	33.87
	21	57.4	17.12	68.3	20.80	79.5	25.58	85.0	28.18	90.5	30.91	97.8	34.35	99.9	34.65
	23	57.4	17.54	68.3	22.20	79.5	27.40	85.0	30.18	90.5	33.14	96.5	35.92	98.4	36.23
	25	57.4	18.69	68.3	23.71	79.5	29.33	85.0	32.36	90.5	35.50	95.0	37.50	97.1	37.80
	27	57.4	19.96	68.3	25.28	79.5	31.33	85.0	34.59	90.5	37.98	93.5	39.07	95.6	39.43
	29	57.4	21.23	68.3	26.97	79.5	33.45	85.0	36.96	90.2	40.34	92.3	40.70	94.4	41.00
	31	57.4	22.62	68.3	28.79	79.5	35.68	85.0	39.43	88.9	41.91	90.8	42.27	92.9	42.64
	33	57.4	24.01	68.3	30.66	79.5	38.04	85.0	42.09	87.4	43.48	89.6	43.85	91.7	44.27
35	57.4	25.52	68.3	32.60	79.5	40.58	85.0	44.88	85.9	45.06	88.0	45.48	90.2	45.85	
37	57.4	27.15	68.3	34.72	79.5	43.24	83.5	46.45	84.7	46.69	86.8	47.11	88.6	47.48	
39	57.4	28.85	68.3	36.89	79.5	46.02	82.3	48.02	83.2	48.26	85.3	48.69	87.4	49.17	
41	57.4	30.19	68.3	38.24	79.5	47.71	81.0	48.36	82.5	49.01	83.8	49.83	86.2	50.18	
43	57.4	31.54	68.3	39.59	79.5	48.59	79.7	48.92	81.9	49.48	84.3	50.16	84.6	50.74	
45	57.4	33.33	68.3	41.38	79.5	49.42	78.0	49.59	81.5	50.38	83.6	50.93	82.9	51.41	
48	57.4	34.80	68.3	42.83	79.5	49.50	74.8	50.16	81.4	51.27	78.5	51.46	81.1	51.89	

Abbreviations:

CR: Combination ratio

TC: Total capacity (kW)

PI: Power input (compressor + outdoor fan motor) (kW)

Notes:

Shaded cells indicate rating condition.

Table continued on next page ...

Table 2-8.13: 32HP cooling capacity (continued)

Combination (%) (Capacity index)	Outdoor temperature (°C DB)	Indoor temperature(°C DB/WB)													
		DB:20.8,WB:14		DB:23.3,WB:16		DB:25.8,WB:18		DB:27,WB:19		DB:28.2,WB:20		DB:30.7,WB:22		DB:32,WB:24	
		TC kW	PI kW	TC kW	PI kW	TC kW	PI kW	TC kW	PI kW	TC kW	PI kW	TC kW	PI kW	TC kW	PI kW
90%	-5	51.6	12.46	61.6	14.95	71.6	17.64	76.5	19.25	81.4	20.47	91.4	23.54	101.4	26.96
	-2	51.6	12.58	61.6	15.11	71.6	17.87	76.5	19.52	81.4	20.72	91.4	23.77	101.4	27.22
	0	51.6	12.77	61.6	15.30	71.6	18.14	76.5	19.75	81.4	20.99	91.4	24.04	101.4	27.43
	2	51.6	12.96	61.6	15.49	71.6	18.33	76.5	20.05	81.4	21.32	91.4	24.54	101.4	27.84
	4	51.6	13.16	61.6	15.72	71.6	18.63	76.5	20.32	81.4	21.59	91.4	24.92	101.4	28.24
	6	51.6	13.34	61.6	16.03	71.6	18.98	76.5	20.70	81.4	21.97	91.4	25.31	101.4	28.72
	8	51.6	13.59	61.6	16.33	71.6	19.37	76.5	20.97	81.4	22.35	91.4	25.78	101.4	28.99
	10	51.6	13.85	61.6	16.69	71.6	19.72	76.5	21.29	81.4	22.86	91.4	26.11	101.4	29.45
	12	51.6	14.09	61.6	16.99	71.6	20.08	76.5	21.64	81.4	23.29	91.4	26.61	101.4	29.99
	14	51.6	14.33	61.6	17.30	71.6	20.44	76.5	22.07	81.4	23.71	91.4	27.09	101.4	30.54
	16	51.6	14.57	61.6	17.60	71.6	20.87	76.5	22.50	81.4	24.19	91.4	27.64	101.1	31.08
	18	51.6	14.82	61.6	17.96	71.6	21.23	76.5	22.92	81.4	24.67	91.4	28.18	99.9	32.05
	20	51.6	15.12	61.6	18.37	71.6	21.65	76.5	23.40	81.4	25.58	91.4	30.30	98.4	33.56
	21	51.6	15.24	61.6	18.50	71.6	22.01	76.5	24.19	81.4	26.49	91.4	31.39	97.8	34.35
	23	51.6	15.54	61.6	19.23	71.6	23.58	76.5	25.95	81.4	28.42	91.4	33.68	96.2	35.92
	25	51.6	16.39	61.6	20.56	71.6	25.22	76.5	27.76	81.4	30.36	91.4	36.05	95.0	37.49
	27	51.6	17.42	61.6	21.89	71.6	26.91	76.5	29.63	81.4	32.48	91.4	38.58	93.5	39.07
	29	51.6	18.57	61.6	23.34	71.6	28.73	76.5	31.63	81.4	34.71	90.5	40.34	92.3	40.64
	31	51.6	19.72	61.6	24.86	71.6	30.60	76.5	33.74	81.4	37.01	88.9	41.91	90.8	42.27
	33	51.6	20.92	61.6	26.43	71.6	32.66	76.5	35.98	81.4	39.49	87.7	43.54	89.6	43.84
35	51.6	22.25	61.6	28.12	71.6	34.77	76.5	38.34	81.4	42.09	86.2	45.12	88.0	45.48	
37	51.6	23.58	61.6	29.88	71.6	37.01	76.5	40.82	81.4	44.87	84.7	46.69	86.8	47.05	
39	51.6	25.04	61.6	31.81	71.6	39.37	76.5	43.48	81.4	47.78	83.5	48.32	85.3	48.68	
41	51.6	25.90	61.6	33.25	71.6	40.81	76.5	44.63	81.4	48.07	82.9	49.55	84.7	49.83	
43	51.6	27.15	61.6	34.69	71.6	42.25	76.5	45.78	81.4	49.09	82.5	50.20	84.0	50.61	
45	51.6	28.87	61.6	36.41	71.6	43.97	76.5	47.32	81.4	50.45	82.0	50.72	82.7	51.28	
48	51.6	30.47	61.6	38.09	71.6	45.63	76.5	47.92	81.4	50.88	81.3	51.43	80.5	51.97	
80%	-5	45.8	10.98	54.6	12.98	63.4	15.37	68.0	16.34	72.6	17.60	81.4	20.35	90.2	23.22
	-2	45.8	11.14	54.6	13.14	63.4	15.50	68.0	16.60	72.6	17.76	81.4	20.54	90.2	23.45
	0	45.8	11.34	54.6	13.31	63.4	15.70	68.0	16.79	72.6	18.09	81.4	20.83	90.2	23.77
	2	45.8	11.56	54.6	13.50	63.4	15.92	68.0	17.12	72.6	18.41	81.4	21.25	90.2	24.22
	4	45.8	11.76	54.6	13.73	63.4	16.22	68.0	17.51	72.6	18.73	81.4	21.64	90.2	24.55
	6	45.8	11.95	54.6	14.05	63.4	16.47	68.0	17.89	72.6	19.09	81.4	21.96	90.2	24.97
	8	45.8	12.18	54.6	14.37	63.4	16.86	68.0	18.18	72.6	19.51	81.4	22.29	90.2	25.45
	10	45.8	12.28	54.6	14.70	63.4	17.30	68.0	18.63	72.6	19.96	81.4	22.80	90.2	25.71
	12	45.8	12.46	54.6	14.94	63.4	17.60	68.0	18.99	72.6	20.38	81.4	23.22	90.2	26.19
	14	45.8	12.70	54.6	15.24	63.4	17.90	68.0	19.29	72.6	20.74	81.4	23.65	90.2	26.67
	16	45.8	12.88	54.6	15.48	63.4	18.26	68.0	19.66	72.6	21.11	81.4	24.13	90.2	27.16
	18	45.8	13.13	54.6	15.79	63.4	18.63	68.0	20.08	72.6	21.53	81.4	24.62	90.2	27.70
	20	45.8	13.37	54.6	16.09	63.4	18.99	68.0	20.44	72.6	21.96	81.4	25.52	90.2	29.64
	21	45.8	13.49	54.6	16.21	63.4	19.17	68.0	20.68	72.6	22.44	81.4	26.43	90.2	30.72
	23	45.8	13.73	54.6	16.57	63.4	20.08	68.0	22.01	72.6	24.01	81.4	28.31	90.2	32.96
	25	45.8	14.15	54.6	17.60	63.4	21.47	68.0	23.53	72.6	25.64	81.4	30.30	90.2	35.26
	27	45.8	15.06	54.6	18.75	63.4	22.86	68.0	25.10	72.6	27.40	81.4	32.36	90.2	37.74
	29	45.8	16.03	54.6	19.96	63.4	24.37	68.0	26.73	72.6	29.27	81.4	34.54	90.2	40.34
	31	45.8	16.99	54.6	21.23	63.4	25.95	68.0	28.49	72.6	31.21	81.4	36.89	88.6	41.92
	33	45.8	18.08	54.6	22.56	63.4	27.64	68.0	30.36	72.6	33.20	81.4	39.31	87.4	43.48
35	45.8	19.17	54.6	24.01	63.4	29.39	68.0	32.30	72.6	35.38	81.4	41.92	85.9	45.06	
37	45.8	20.32	54.6	25.46	63.4	31.27	68.0	34.41	72.6	37.68	81.4	44.70	84.7	46.63	
39	45.8	21.53	54.6	27.16	63.4	33.27	68.0	36.59	72.6	40.10	81.4	47.60	83.2	48.26	
41	45.8	22.02	54.6	27.40	63.4	33.75	68.0	37.56	72.6	40.83	81.4	48.81	82.7	49.11	
43	45.8	22.66	54.6	27.64	63.4	34.24	68.0	38.21	72.6	41.39	81.4	49.38	82.2	49.64	
45	45.8	23.31	54.6	27.96	63.4	34.90	68.0	39.01	72.6	42.11	81.4	49.92	81.1	50.45	
48	45.8	24.06	54.6	28.13	63.4	35.43	68.0	39.53	72.6	42.44	81.4	50.38	80.5	51.09	

Abbreviations:
 CR: Combination ratio
 TC: Total capacity (kW)
 PI: Power input (compressor + outdoor fan motor) (kW)

Notes:
 Shaded cells indicate rating condition.

Table continued on next page ...

Table 2-8.13: 32HP cooling capacity (continued)

Combination (%) (Capacity index)	Outdoor temperature (°C DB)	Indoor temperature(°C DB/WB)													
		DB:20.8,WB:14		DB:23.3,WB:16		DB:25.8,WB:18		DB:27,WB:19		DB:28.2,WB:20		DB:30.7,WB:22		DB:32,WB:24	
		TC kW	PI kW	TC kW	PI kW	TC kW	PI kW	TC kW	PI kW	TC kW	PI kW	TC kW	PI kW	TC kW	PI kW
70%	-5	40.1	9.80	48.0	11.49	55.6	13.02	59.5	13.96	63.4	14.90	71.0	17.05	78.9	19.60
	-2	40.1	9.88	48.0	11.55	55.6	13.10	59.5	14.23	63.4	15.17	71.0	17.32	78.9	19.87
	0	40.1	9.94	48.0	11.71	55.6	13.37	59.5	14.50	63.4	15.44	71.0	17.67	78.9	20.14
	2	40.1	9.99	48.0	11.76	55.6	13.59	59.5	14.77	63.4	15.71	71.0	18.05	78.9	20.46
	4	40.1	10.12	48.0	12.06	55.6	13.89	59.5	15.04	63.4	16.06	71.0	18.34	78.9	20.95
	6	40.1	10.28	48.0	12.27	55.6	14.23	59.5	15.52	63.4	16.43	71.0	18.66	78.9	21.35
	8	40.1	10.47	48.0	12.62	55.6	14.55	59.5	15.76	63.4	16.78	71.0	19.20	78.9	21.75
	10	40.1	10.69	48.0	12.82	55.6	14.94	59.5	16.09	63.4	17.24	71.0	19.60	78.9	22.01
	12	40.1	10.95	48.0	13.00	55.6	15.24	59.5	16.39	63.4	17.54	71.0	19.96	78.9	22.44
	14	40.1	11.13	48.0	13.24	55.6	15.48	59.5	16.63	63.4	17.84	71.0	20.32	78.9	22.86
	16	40.1	11.31	48.0	13.49	55.6	15.78	59.5	17.00	63.4	18.20	71.0	20.69	78.9	23.28
	18	40.1	11.49	48.0	13.73	55.6	16.09	59.5	17.30	63.4	18.51	71.0	21.11	78.9	23.77
	20	40.1	11.67	48.0	13.97	55.6	16.39	59.5	17.60	63.4	18.87	71.0	21.53	78.9	24.43
	21	40.1	11.79	48.0	14.09	55.6	16.51	59.5	17.78	63.4	19.05	71.0	21.83	78.9	25.28
	23	40.1	11.97	48.0	14.33	55.6	16.87	59.5	18.39	63.4	20.02	71.0	23.41	78.9	27.10
	25	40.1	12.22	48.0	14.94	55.6	17.96	59.5	19.66	63.4	21.35	71.0	25.04	78.9	28.97
	27	40.1	12.94	48.0	15.91	55.6	19.17	59.5	20.93	63.4	22.80	71.0	26.73	78.9	30.97
	29	40.1	13.73	48.0	16.87	55.6	20.38	59.5	22.32	63.4	24.25	71.0	28.49	78.9	33.08
	31	40.1	14.51	48.0	17.90	55.6	21.71	59.5	23.71	63.4	25.83	71.0	30.36	78.9	35.26
	33	40.1	15.42	48.0	19.05	55.6	23.10	59.5	25.22	63.4	27.52	71.0	32.36	78.9	37.62
35	40.1	16.33	48.0	20.20	55.6	24.50	59.5	26.85	63.4	29.27	71.0	34.47	78.9	40.10	
37	40.1	17.24	48.0	21.41	55.6	26.07	59.5	28.49	63.4	31.15	71.0	36.71	78.9	42.70	
39	40.1	18.27	48.0	22.68	55.6	27.64	59.5	30.30	63.4	33.08	71.0	39.01	78.9	45.48	
41	40.1	19.07	48.0	23.49	55.6	28.45	59.5	31.31	63.4	34.09	71.0	40.62	78.9	47.50	
43	40.1	20.62	48.0	25.10	55.6	29.62	59.5	32.99	63.4	35.10	71.0	42.10	78.9	48.97	
45	40.1	21.08	48.0	25.63	55.6	30.24	59.5	33.52	63.4	36.84	71.0	44.38	78.9	50.85	
48	40.1	21.48	48.0	25.78	55.6	30.61	59.5	34.10	63.4	37.86	71.0	46.46	78.9	52.10	
60%	-5	34.3	8.36	41.0	9.70	47.7	11.30	51.0	12.04	54.3	13.00	61.0	14.60	67.7	16.75
	-2	34.3	8.41	41.0	9.85	47.7	11.51	51.0	12.21	54.3	13.13	61.0	14.82	67.7	16.86
	0	34.3	8.54	41.0	9.97	47.7	11.66	51.0	12.37	54.3	13.35	61.0	15.04	67.7	17.07
	2	34.3	8.69	41.0	10.20	47.7	11.88	51.0	12.61	54.3	13.53	61.0	15.35	67.7	17.29
	4	34.3	8.93	41.0	10.40	47.7	12.11	51.0	12.76	54.3	13.73	61.0	15.59	67.7	17.54
	6	34.3	9.02	41.0	10.59	47.7	12.34	51.0	13.05	54.3	14.01	61.0	15.90	67.7	17.95
	8	34.3	9.19	41.0	10.77	47.7	12.57	51.0	13.29	54.3	14.29	61.0	16.20	67.7	18.23
	10	34.3	9.37	41.0	11.01	47.7	12.76	51.0	13.67	54.3	14.57	61.0	16.51	67.7	18.50
	12	34.3	9.56	41.0	11.19	47.7	13.00	51.0	13.91	54.3	14.82	61.0	16.81	67.7	18.81
	14	34.3	9.68	41.0	11.37	47.7	13.18	51.0	14.15	54.3	15.12	61.0	17.11	67.7	19.17
	16	34.3	9.80	41.0	11.55	47.7	13.43	51.0	14.39	54.3	15.36	61.0	17.42	67.7	19.53
	18	34.3	9.98	41.0	11.73	47.7	13.67	51.0	14.63	54.3	15.66	61.0	17.72	67.7	19.89
	20	34.3	10.10	41.0	11.97	47.7	13.91	51.0	14.94	54.3	15.96	61.0	18.08	67.7	20.32
	21	34.3	10.22	41.0	12.03	47.7	14.03	51.0	15.06	54.3	16.09	61.0	18.26	67.7	20.50
	23	34.3	10.34	41.0	12.28	47.7	14.27	51.0	15.36	54.3	16.39	61.0	18.99	67.7	21.83
	25	34.3	10.52	41.0	12.46	47.7	14.82	51.0	16.09	54.3	17.42	61.0	20.26	67.7	23.28
	27	34.3	10.95	41.0	13.24	47.7	15.78	51.0	17.17	54.3	18.57	61.0	21.59	67.7	24.85
	29	34.3	11.55	41.0	14.03	47.7	16.81	51.0	18.26	54.3	19.77	61.0	23.04	67.7	26.55
	31	34.3	12.28	41.0	14.88	47.7	17.84	51.0	19.41	54.3	21.04	61.0	24.49	67.7	28.24
	33	34.3	12.94	41.0	15.78	47.7	18.93	51.0	20.62	54.3	22.37	61.0	26.06	67.7	30.11
35	34.3	13.73	41.0	16.75	47.7	20.08	51.0	21.89	54.3	23.76	61.0	27.76	67.7	32.05	
37	34.3	14.51	41.0	17.72	47.7	21.29	51.0	23.22	54.3	25.22	61.0	29.51	67.7	34.11	
39	34.3	15.30	41.0	18.75	47.7	22.56	51.0	24.61	54.3	26.79	61.0	31.32	67.7	36.28	
41	34.3	15.79	41.0	19.56	47.7	23.38	51.0	25.60	54.3	27.77	61.0	32.80	67.7	37.93	
43	34.3	16.28	41.0	20.38	47.7	24.20	51.0	26.36	54.3	28.74	61.0	34.19	67.7	39.57	
45	34.3	17.05	41.0	21.41	47.7	25.18	51.0	27.35	54.3	30.17	61.0	35.73	67.7	41.76	
48	34.3	17.69	41.0	22.33	47.7	26.05	51.0	28.02	54.3	31.30	61.0	36.99	67.7	43.78	

Abbreviations:

CR: Combination ratio

TC: Total capacity (kW)

PI: Power input (compressor + outdoor fan motor) (kW)

Notes:

Shaded cells indicate rating condition.

Table continued on next page ...

Table 2-8.13: 32HP cooling capacity (continued)

Combination (%) (Capacity index)	Outdoor temperature (°C DB)	Indoor temperature(°C DB/WB)													
		DB:20.8,WB:14		DB:23.3,WB:16		DB:25.8,WB:18		DB:27,WB:19		DB:28.2,WB:20		DB:30.7,WB:22		DB:32,WB:24	
		TC	PI	TC	PI	TC	PI	TC	PI	TC	PI	TC	PI	TC	PI
50%	-5	28.7	7.26	34.3	8.40	39.8	9.65	42.5	10.10	45.2	10.66	50.7	12.12	56.5	13.06
	-2	28.7	7.31	34.3	8.57	39.8	9.75	42.5	10.24	45.2	10.85	50.7	12.28	56.5	13.24
	0	28.7	7.44	34.3	8.71	39.8	9.93	42.5	10.38	45.2	10.97	50.7	12.49	56.5	13.46
	2	28.7	7.54	34.3	8.81	39.8	10.10	42.5	10.54	45.2	11.16	50.7	12.54	56.5	13.72
	4	28.7	7.62	34.3	8.97	39.8	10.21	42.5	10.66	45.2	11.39	50.7	12.85	56.5	14.07
	6	28.7	7.76	34.3	9.11	39.8	10.36	42.5	10.90	45.2	11.60	50.7	13.05	56.5	14.49
	8	28.7	7.94	34.3	9.27	39.8	10.54	42.5	11.15	45.2	11.76	50.7	13.26	56.5	14.96
	10	28.7	8.10	34.3	9.37	39.8	10.70	42.5	11.32	45.2	12.09	50.7	13.61	56.5	15.18
	12	28.7	8.16	34.3	9.49	39.8	10.89	42.5	11.55	45.2	12.34	50.7	13.85	56.5	15.42
	14	28.7	8.28	34.3	9.62	39.8	11.01	42.5	11.79	45.2	12.52	50.7	14.09	56.5	15.72
	16	28.7	8.41	34.3	9.74	39.8	11.19	42.5	11.97	45.2	12.70	50.7	14.33	56.5	15.97
	18	28.7	8.53	34.3	9.92	39.8	11.37	42.5	12.15	45.2	12.94	50.7	14.57	56.5	16.27
	20	28.7	8.65	34.3	10.04	39.8	11.55	42.5	12.34	45.2	13.18	50.7	14.82	56.5	16.57
	21	28.7	8.71	34.3	10.16	39.8	11.67	42.5	12.46	45.2	13.30	50.7	15.00	56.5	16.75
	23	28.7	8.83	34.3	10.28	39.8	11.85	42.5	12.70	45.2	13.55	50.7	15.24	56.5	17.11
	25	28.7	8.95	34.3	10.46	39.8	12.09	42.5	12.94	45.2	13.97	50.7	16.02	56.5	18.26
	27	28.7	9.13	34.3	10.89	39.8	12.76	42.5	13.79	45.2	14.82	50.7	17.05	56.5	19.47
	29	28.7	9.62	34.3	11.49	39.8	13.55	42.5	14.63	45.2	15.78	50.7	18.14	56.5	20.74
	31	28.7	10.16	34.3	12.15	39.8	14.33	42.5	15.54	45.2	16.75	50.7	19.29	56.5	22.07
	33	28.7	10.77	34.3	12.88	39.8	15.24	42.5	16.45	45.2	17.78	50.7	20.50	56.5	23.46
35	28.7	11.37	34.3	13.61	39.8	16.09	42.5	17.42	45.2	18.81	50.7	21.77	56.5	24.92	
37	28.7	11.97	34.3	14.39	39.8	17.05	42.5	18.44	45.2	19.96	50.7	23.10	56.5	26.49	
39	28.7	12.64	34.3	15.18	39.8	18.02	42.5	19.53	45.2	21.17	50.7	24.49	56.5	28.12	
41	28.7	13.16	34.3	15.83	39.8	18.67	42.5	20.45	45.2	22.08	50.7	25.80	56.5	29.43	
43	28.7	14.03	34.3	16.92	39.8	19.33	42.5	21.36	45.2	22.65	50.7	27.11	56.5	30.73	
45	28.7	14.35	34.3	17.36	39.8	20.63	42.5	23.02	45.2	23.60	50.7	29.72	56.5	33.35	
48	28.7	14.63	34.3	17.76	39.8	21.77	42.5	24.56	45.2	24.73	50.7	32.05	56.5	35.88	

Abbreviations:

CR: Combination ratio

TC: Total capacity (kW)

PI: Power input (compressor + outdoor fan motor) (kW)

Notes:

Shaded cells indicate rating condition.

8.2 Heating Capacity Tables

Table 2-8.14: 8HP heating capacity

CR	Outdoor air temp.		Indoor air temp. °C DB											
			16		18		20		21		22		24	
	°C DB	°C WB	TC	PI	TC	PI	TC	PI	TC	PI	TC	PI	TC	PI
130%	-25	-25.4	21.06	5.99	20.98	6.10	20.54	6.34	20.47	6.52	20.45	6.70	20.34	6.80
	-19.8	-20	22.14	6.15	22.05	6.28	21.97	6.60	21.88	6.78	21.88	6.96	21.80	7.05
	-18.8	-19	22.31	6.26	22.22	6.37	22.14	6.66	22.14	6.84	22.05	7.02	21.97	7.08
	-16.7	-17	22.65	6.33	22.57	6.48	22.48	6.73	22.48	6.91	22.40	7.09	22.31	7.21
	-13.7	-15	22.99	6.41	22.91	6.58	22.82	6.85	22.82	7.03	22.74	7.21	22.65	7.31
	-11.8	-13	23.34	6.52	23.25	6.68	23.16	6.98	23.16	7.16	23.08	7.34	23.08	7.42
	-9.8	-11	23.68	6.61	23.59	6.80	23.51	7.05	23.51	7.23	23.51	7.41	23.42	7.43
	-9.5	-10	23.85	6.71	23.76	6.87	23.76	7.16	23.68	7.34	23.68	7.52	23.59	7.54
	-8.5	-9.1	24.02	6.80	23.93	6.97	23.85	7.24	23.85	7.42	23.85	7.60	23.76	7.62
	-7	-7.6	24.28	6.81	24.19	7.07	24.19	7.31	24.10	7.48	24.10	7.71	24.02	7.72
	-5	-5.6	26.16	7.11	26.07	7.26	25.99	7.54	25.99	7.76	25.90	7.75	25.81	7.81
	-3	-3.7	26.50	7.28	26.41	7.38	26.33	7.66	26.33	7.89	26.24	7.86	26.16	7.91
	0	-0.7	27.01	7.50	26.93	7.45	26.84	7.76	26.84	7.97	26.75	7.98	26.75	7.98
	3	2.2	29.84	7.93	29.49	7.94	29.40	8.16	29.32	8.31	29.32	8.39	29.23	8.46
	5	4.1	37.10	9.58	35.61	9.46	35.05	9.42	33.68	9.12	32.31	9.02	29.66	8.63
7	6	37.70	9.65	36.29	9.21	35.05	8.96	33.68	8.73	32.31	8.65	29.66	8.33	
9	7.9	37.70	9.18	36.29	8.77	35.05	8.69	33.68	8.57	32.31	8.43	29.66	8.14	
11	9.8	37.70	8.74	36.29	8.41	35.05	8.39	33.68	8.29	32.31	8.18	29.66	7.83	
13	11.8	37.70	8.31	36.29	8.16	35.05	8.16	33.68	8.14	32.31	8.00	29.66	7.69	
15	13.7	37.70	8.05	36.29	7.98	35.05	7.93	33.68	7.82	32.31	7.77	29.66	7.41	
120%	-25	-25.4	20.86	6.53	20.77	6.77	20.75	7.01	20.69	7.18	20.59	7.34	20.53	7.45
	-19.8	-20	22.11	6.71	22.03	6.93	21.94	7.13	21.94	7.30	21.86	7.47	21.77	7.60
	-18.8	-19	22.29	6.80	22.20	6.94	22.11	7.25	22.11	7.42	22.03	7.59	21.94	7.68
	-16.7	-17	22.63	6.90	22.54	7.04	22.46	7.35	22.46	7.52	22.37	7.69	22.37	7.71
	-13.7	-15	22.97	6.99	22.89	7.19	22.80	7.39	22.80	7.56	22.80	7.73	22.71	7.79
	-11.8	-13	23.31	7.10	23.23	7.26	23.18	7.48	23.14	7.65	23.14	7.82	23.06	7.88
	-9.8	-11	23.66	7.13	23.57	7.31	23.57	7.57	23.49	7.74	23.49	7.91	23.40	8.02
	-9.5	-10	23.83	7.22	23.74	7.37	23.74	7.62	23.66	7.79	23.66	7.96	23.57	8.12
	-8.5	-9.1	24.00	7.29	23.91	7.46	23.91	7.71	23.83	7.88	23.83	8.05	23.74	8.13
	-7	-7.6	24.26	7.42	24.17	7.60	24.17	7.79	24.09	7.96	24.09	8.13	24.00	8.23
	-5	-5.6	26.14	7.48	26.06	7.66	25.97	7.87	25.97	8.04	25.97	8.21	25.89	8.36
	-3	-3.7	26.49	7.61	26.40	7.78	26.31	7.98	26.31	8.14	26.23	8.31	26.23	8.41
	0	-0.7	27.00	7.70	26.91	7.89	26.83	8.04	26.83	8.21	26.83	8.38	26.74	8.47
	3	2.2	29.49	8.17	29.49	8.39	29.40	8.45	29.31	8.62	29.31	8.79	27.43	8.38
	5	4.1	37.11	9.16	34.89	9.07	32.40	8.92	31.11	8.74	29.91	8.64	27.43	8.13
7	6	37.37	9.09	34.89	8.69	32.40	8.47	31.11	8.32	29.91	8.27	27.43	7.93	
9	7.9	37.37	8.70	34.89	8.30	32.40	8.21	31.11	8.04	29.91	8.03	27.43	7.69	
11	9.8	37.37	8.42	34.89	8.12	32.40	7.93	31.11	7.81	29.91	7.74	27.43	7.40	
13	11.8	37.37	8.21	34.89	7.92	32.40	7.71	31.11	7.69	29.91	7.60	27.43	7.26	
15	13.7	37.37	8.03	34.89	7.68	32.40	7.49	31.11	7.40	29.91	7.34	27.43	6.99	
110%	-25	-25.4	21.12	6.72	21.02	6.88	20.91	7.03	20.94	6.93	20.87	7.06	20.86	7.25
	-19.8	-20	22.03	6.82	21.94	6.97	21.86	7.13	21.86	7.02	21.77	7.16	21.77	7.34
	-18.8	-19	22.20	6.92	22.11	7.08	22.03	7.23	22.03	7.03	21.94	7.23	21.94	7.36
	-16.7	-17	22.54	7.02	22.46	7.18	22.37	7.33	22.37	7.17	22.37	7.32	22.29	7.45
	-13.7	-15	22.89	7.08	22.80	7.24	22.71	7.40	22.71	7.21	22.71	7.35	22.63	7.53
	-11.8	-13	23.23	7.19	23.14	7.34	23.14	7.50	23.06	7.29	23.06	7.44	22.97	7.62
	-9.8	-11	23.57	7.19	23.49	7.35	23.49	7.50	23.40	7.42	23.40	7.53	23.31	7.72
	-9.5	-10	23.74	7.27	23.74	7.42	23.66	7.58	23.57	7.45	23.57	7.62	23.49	7.80
	-8.5	-9.1	23.91	7.35	23.83	7.50	23.83	7.66	23.74	7.52	23.74	7.70	23.66	7.89
	-7	-7.6	24.17	7.43	24.09	7.58	24.09	7.74	24.00	7.63	24.00	7.78	23.91	7.91
	-5	-5.6	26.06	7.52	25.97	7.68	25.89	7.84	25.89	7.70	25.89	7.83	25.11	7.82
	-3	-3.7	26.40	7.58	26.31	7.74	26.23	7.89	26.23	7.77	26.23	7.93	25.11	7.69
	0	-0.7	26.91	7.76	26.83	7.92	26.83	8.08	26.74	7.83	26.74	8.00	25.11	7.58
	3	2.2	29.40	8.11	29.40	8.27	29.31	8.42	28.54	8.14	27.43	8.06	25.11	7.52
	5	4.1	34.29	8.85	31.97	8.83	29.74	8.23	28.54	8.00	27.43	7.86	25.11	7.49
7	6	34.29	8.52	31.97	8.31	29.74	7.81	28.54	7.61	27.43	7.49	25.11	7.30	
9	7.9	34.29	8.14	31.97	7.87	29.74	7.54	28.54	7.42	27.43	7.33	25.11	7.17	
11	9.8	34.29	7.84	31.97	7.58	29.74	7.32	28.54	7.15	27.43	7.10	25.11	6.94	
13	11.8	34.29	7.61	31.97	7.34	29.74	7.09	28.54	6.94	27.43	6.85	25.11	6.70	
15	13.7	34.29	7.40	31.97	7.10	29.74	6.85	28.54	6.70	27.43	6.62	25.11	6.46	

Abbreviations:

CR: Combination ratio

TC: Total capacity (kW)

PI: Power input (compressor + outdoor fan motor) (kW)

Notes:

Shaded cells indicate rating condition.

Table 2-8.14: 8HP heating capacity (continued)

CR	Outdoor air temp.		Indoor air temp. °C DB											
			16		18		20		21		22		24	
	°C DB	°C WB	TC	PI	TC	PI	TC	PI	TC	PI	TC	PI	TC	PI
100%	-25	-25.4	21.13	8.40	21.05	8.48	20.96	8.53	20.96	8.62	20.96	8.67	20.88	8.79
	-19.8	-20	22.11	8.40	22.03	8.49	21.94	8.58	21.94	8.63	21.94	8.68	21.86	8.73
	-18.8	-19	22.46	8.42	22.37	8.51	22.29	8.60	22.29	8.64	22.29	8.69	22.20	8.66
	-16.7	-17	22.80	8.43	22.71	8.52	22.71	8.61	22.63	8.66	22.63	8.72	22.54	8.61
	-13.7	-15	23.14	8.45	23.06	8.53	23.06	8.63	22.97	8.67	22.97	8.73	22.89	8.51
	-11.8	-13	23.49	8.46	23.40	8.55	23.40	8.64	23.31	8.69	23.31	8.74	22.89	8.42
	-9.8	-11	23.66	8.47	23.66	8.56	23.57	8.65	23.57	8.69	23.49	8.75	22.89	8.40
	-9.5	-10	23.83	8.48	23.74	8.56	23.74	8.67	23.66	8.70	23.66	8.76	22.89	8.33
	-8.5	-9.1	24.09	8.49	24.09	8.57	24.00	8.70	23.91	8.72	23.91	8.77	22.89	8.21
	-7	-7.6	25.97	8.50	25.89	8.58	25.89	8.88	25.80	9.03	24.94	8.59	22.89	8.18
	-5	-5.6	26.31	8.51	26.23	8.58	26.23	8.67	25.97	8.78	24.94	8.34	22.89	7.95
	-3	-3.7	26.83	8.52	26.74	8.59	26.74	8.39	25.97	8.27	24.94	8.07	22.89	7.68
	0	-0.7	27.51	8.53	29.06	8.59	27.00	8.15	25.97	7.89	24.94	7.68	22.89	7.35
	3	2.2	29.31	8.36	29.06	8.38	27.00	7.92	25.97	7.51	24.94	7.22	22.89	6.99
	5	4.1	31.11	8.23	29.06	7.97	27.00	7.55	25.97	7.17	24.94	6.93	22.89	6.68
7	6	31.11	8.12	29.06	7.56	27.00	7.07	25.97	6.79	24.94	6.64	22.89	6.38	
9	7.9	31.11	7.66	29.06	7.16	27.00	6.87	25.97	6.62	24.94	6.45	22.89	6.18	
11	9.8	31.11	7.17	29.06	6.72	27.00	6.64	25.97	6.36	24.94	6.21	22.89	5.92	
13	11.8	31.11	6.72	29.06	6.55	27.00	6.38	25.97	6.13	24.94	5.99	22.89	5.72	
15	13.7	31.11	6.39	29.06	6.27	27.00	6.15	25.97	5.91	24.94	5.78	22.89	5.49	
90%	-25	-25.4	20.97	8.39	20.86	8.47	20.79	8.56	20.77	8.67	20.77	8.71	20.57	8.16
	-19.8	-20	21.86	8.53	21.77	8.61	21.69	8.70	21.69	8.76	21.69	8.81	20.57	7.99
	-18.8	-19	22.03	8.54	21.94	8.62	21.86	8.72	21.86	8.77	21.86	8.78	20.57	7.91
	-16.7	-17	22.37	8.55	22.29	8.63	22.29	8.73	22.20	8.78	22.20	8.60	20.57	7.74
	-13.7	-15	22.71	8.56	22.63	8.65	22.63	8.75	22.54	8.79	22.46	8.43	20.57	7.59
	-11.8	-13	23.06	8.58	22.97	8.66	22.97	8.76	22.89	8.67	22.46	8.25	20.57	7.45
	-9.8	-11	23.40	8.59	23.40	8.68	23.31	8.77	23.31	8.50	22.46	8.10	20.57	7.30
	-9.5	-10	23.57	8.60	23.57	8.68	23.49	8.78	23.40	8.42	22.46	8.02	20.57	7.23
	-8.5	-9.1	23.74	8.61	23.66	8.69	23.66	8.76	23.40	8.35	22.46	7.95	20.57	7.17
	-7	-7.6	24.00	8.62	24.00	8.58	23.91	8.63	23.40	8.23	22.46	7.83	20.57	7.07
	-5	-5.6	25.89	8.64	25.80	8.21	24.34	8.27	23.40	7.96	22.46	7.59	20.57	6.86
	-3	-3.7	26.23	8.65	26.14	7.85	24.34	7.86	23.40	7.66	22.46	7.35	20.57	6.69
	0	-0.7	26.74	8.66	26.14	7.45	24.34	7.53	23.40	7.30	22.46	6.99	20.57	6.51
	3	2.2	28.03	8.67	26.14	7.06	24.34	7.10	23.40	7.02	22.46	6.67	20.57	6.29
	5	4.1	28.03	8.46	26.14	6.71	24.34	6.78	23.40	6.66	22.46	6.36	20.57	6.04
7	6	28.03	7.35	26.14	6.59	24.34	6.34	23.40	6.09	22.46	5.86	20.57	5.38	
9	7.9	28.03	6.90	26.14	6.46	24.34	6.02	23.40	5.81	22.46	5.59	20.57	5.17	
11	9.8	28.03	6.50	26.14	6.11	24.34	5.74	23.40	5.54	22.46	5.36	20.57	4.99	
13	11.8	28.03	6.14	26.14	5.81	24.34	5.48	23.40	5.32	22.46	5.15	20.57	4.82	
15	13.7	28.03	5.89	26.14	5.59	24.34	5.29	23.40	5.15	22.46	5.01	20.57	4.71	
80%	-25	-25.4	20.94	8.90	20.85	9.01	20.95	8.73	20.74	8.32	19.97	7.96	18.26	7.22
	-19.8	-20	21.77	8.57	21.69	8.66	21.60	8.36	20.74	7.98	19.97	7.60	18.26	6.87
	-18.8	-19	21.94	8.58	21.86	8.66	21.60	8.28	20.74	7.90	19.97	7.52	18.26	6.80
	-16.7	-17	22.29	8.59	22.20	8.68	21.60	8.11	20.74	7.74	19.97	7.37	18.26	6.65
	-13.7	-15	22.63	8.61	22.54	8.69	21.60	7.95	20.74	7.58	19.97	7.23	18.26	6.53
	-11.8	-13	22.97	8.62	22.89	8.53	21.60	7.79	20.74	7.43	19.97	7.09	18.26	6.41
	-9.8	-11	23.31	8.63	23.23	8.35	21.60	7.65	20.74	7.29	19.97	6.96	18.26	6.29
	-9.5	-10	23.49	8.64	23.23	8.27	21.60	7.56	20.74	7.22	19.97	6.89	18.26	6.23
	-8.5	-9.1	23.66	8.65	23.23	8.20	21.60	7.50	20.74	7.16	19.97	6.83	18.26	6.18
	-7	-7.6	23.91	8.66	23.23	8.08	21.60	7.40	20.74	7.07	19.97	6.74	18.26	6.10
	-5	-5.6	24.94	8.48	23.23	7.82	21.60	7.17	20.74	6.85	19.97	6.54	18.26	5.93
	-3	-3.7	24.94	8.78	23.23	7.53	21.60	6.87	20.74	6.59	19.97	6.31	18.26	5.76
	0	-0.7	24.94	8.67	23.23	7.19	21.60	6.63	20.74	6.39	19.97	6.12	18.26	5.63
	3	2.2	24.94	8.01	23.23	6.78	21.60	6.25	20.74	6.17	19.97	5.89	18.26	5.41
	5	4.1	24.94	7.32	23.23	6.41	21.60	5.96	20.74	5.92	19.97	5.61	18.26	5.29
7	6	24.94	6.42	23.23	6.00	21.60	5.57	20.74	5.36	19.97	5.16	18.26	4.75	
9	7.9	24.94	6.09	23.23	5.71	21.60	5.34	20.74	5.16	19.97	4.97	18.26	4.61	
11	9.8	24.94	5.78	23.23	5.45	21.60	5.13	20.74	4.97	19.97	4.80	18.26	4.49	
13	11.8	24.94	5.52	23.23	5.23	21.60	4.95	20.74	4.80	19.97	4.66	18.26	4.38	
15	13.7	24.94	5.33	23.23	5.07	21.60	4.81	20.74	4.69	19.97	4.56	18.26	4.31	

Abbreviations:

CR: Combination ratio

TC: Total capacity (kW)

PI: Power input (compressor + outdoor fan motor) (kW)

Notes:

Shaded cells indicate rating condition.

Table 2-8.14: 8HP heating capacity (continued)

CR	Outdoor air temp.		Indoor air temp. °C DB											
			16		18		20		21		22		24	
	°C DB	°C WB	TC kW	PI kW	TC kW	PI kW	TC kW	PI kW	TC kW	PI kW	TC kW	PI kW	TC kW	PI kW
70%	-25	-25.4	21.60	9.00	20.31	8.33	18.94	8.18	18.17	8.03	17.49	7.93	16.03	7.64
	-19.8	-20	21.60	8.57	20.31	7.89	18.94	7.73	18.17	7.58	17.49	7.48	16.03	7.18
	-18.8	-19	21.77	8.48	20.31	7.80	18.94	7.65	18.17	7.50	17.49	7.40	16.03	7.10
	-16.7	-17	21.77	8.31	20.31	7.65	18.94	7.51	18.17	7.36	17.49	7.26	16.03	6.97
	-13.7	-15	21.77	8.14	20.31	7.50	18.94	7.37	18.17	7.22	17.49	7.12	16.03	6.82
	-11.8	-13	21.77	7.98	20.31	7.35	18.94	7.25	18.17	7.10	17.49	7.00	16.03	6.70
	-9.8	-11	21.77	7.82	20.31	7.21	18.94	7.11	18.17	6.96	17.49	6.86	16.03	6.57
	-9.5	-10	21.77	7.75	20.31	7.15	18.94	6.93	18.17	6.78	17.49	6.68	16.03	6.39
	-8.5	-9.1	21.77	7.68	20.31	7.09	18.94	6.70	18.17	6.55	17.49	6.45	16.03	6.16
	-7	-7.6	21.77	7.58	20.31	6.98	18.94	6.41	18.17	6.26	17.49	6.16	16.03	5.86
	-5	-5.6	21.77	7.34	20.31	6.78	18.94	6.24	18.17	6.09	17.49	5.99	16.03	5.69
	-3	-3.7	21.77	6.95	20.31	6.57	18.94	6.05	18.17	5.91	17.49	5.81	16.03	5.51
	0	-0.7	21.77	6.58	20.31	6.29	18.94	5.80	18.17	5.65	17.49	5.55	16.03	5.25
	3	2.2	21.77	6.21	20.31	5.94	18.94	5.44	18.17	5.29	17.49	5.19	16.03	4.90
	5	4.1	21.77	5.92	20.31	5.57	18.94	5.24	18.17	5.09	17.49	4.99	16.03	4.69
60%	7	6	21.77	5.69	20.31	5.33	18.94	4.97	18.17	4.83	17.49	4.73	16.03	4.43
	9	7.9	21.77	5.45	20.31	5.12	18.94	4.80	18.17	4.65	17.49	4.55	16.03	4.26
	11	9.8	21.77	5.23	20.31	4.95	18.94	4.61	18.17	4.46	17.49	4.36	16.03	4.06
	13	11.8	21.77	5.04	20.31	4.74	18.94	4.39	18.17	4.24	17.49	4.14	16.03	3.84
	15	13.7	21.77	4.86	20.31	4.53	18.94	4.22	18.17	4.07	17.49	3.97	16.03	3.67
	-25	-25.4	18.69	8.39	17.49	7.93	16.20	7.56	15.60	7.39	14.91	7.08	13.71	6.71
	-19.8	-20	18.69	7.95	17.49	7.57	16.20	7.28	15.60	7.07	14.91	6.75	13.71	6.37
	-18.8	-19	18.69	7.74	17.49	7.31	16.20	7.02	15.60	6.83	14.91	6.49	13.71	6.14
	-16.7	-17	18.69	7.50	17.49	7.08	16.20	6.80	15.60	6.57	14.91	6.25	13.71	5.89
	-13.7	-15	18.69	7.24	17.49	6.87	16.20	6.59	15.60	6.33	14.91	6.00	13.71	5.65
	-11.8	-13	18.69	6.98	17.49	6.62	16.20	6.34	15.60	6.11	14.91	5.75	13.71	5.40
	-9.8	-11	18.69	6.76	17.49	6.37	16.20	6.04	15.60	5.83	14.91	5.50	13.71	5.20
	-9.5	-10	18.69	6.52	17.49	6.11	16.20	5.79	15.60	5.58	14.91	5.26	13.71	4.92
	-8.5	-9.1	18.69	6.25	17.49	5.89	16.20	5.55	15.60	5.34	14.91	5.02	13.71	4.64
	-7	-7.6	18.69	6.01	17.49	5.64	16.20	5.35	15.60	5.16	14.91	4.82	13.71	4.43
-5	-5.6	18.69	5.79	17.49	5.44	16.20	5.09	15.60	4.95	14.91	4.63	13.71	4.22	
-3	-3.7	18.69	5.59	17.49	5.22	16.20	4.86	15.60	4.75	14.91	4.42	13.71	4.07	
0	-0.7	18.69	5.36	17.49	5.01	16.20	4.64	15.60	4.52	14.91	4.20	13.71	4.00	
3	2.2	18.69	5.12	17.49	4.77	16.20	4.47	15.60	4.34	14.91	3.99	13.71	3.85	
5	4.1	18.69	4.86	17.49	4.57	16.20	4.30	15.60	4.14	14.91	3.90	13.71	3.77	
7	6	18.69	4.64	17.49	4.37	16.20	4.10	15.60	3.97	14.91	3.88	13.71	3.70	
9	7.9	18.69	4.56	17.49	4.28	16.20	4.04	15.60	3.88	14.91	3.71	13.71	3.53	
11	9.8	18.69	4.49	17.49	4.21	16.20	3.93	15.60	3.79	14.91	3.64	13.71	3.47	
13	11.8	18.69	4.35	17.49	4.07	16.20	3.81	15.60	3.71	14.91	3.56	13.71	3.39	
15	13.7	18.69	4.30	17.49	3.99	16.20	3.70	15.60	3.62	14.91	3.47	13.71	3.29	
50%	-25	-25.4	15.60	6.95	14.57	6.57	13.54	6.26	12.94	6.12	12.43	5.97	11.40	5.56
	-19.8	-20	15.60	6.58	14.57	6.27	13.54	6.03	12.94	5.85	12.43	5.69	11.40	5.27
	-18.8	-19	15.60	6.41	14.57	6.05	13.54	5.81	12.94	5.66	12.43	5.47	11.40	5.08
	-16.7	-17	15.60	6.21	14.57	5.86	13.54	5.63	12.94	5.44	12.43	5.27	11.40	4.88
	-13.7	-15	15.60	5.99	14.57	5.69	13.54	5.46	12.94	5.24	12.43	5.07	11.40	4.68
	-11.8	-13	15.60	5.78	14.57	5.48	13.54	5.25	12.94	5.06	12.43	4.86	11.40	4.47
	-9.8	-11	15.60	5.59	14.57	5.27	13.54	5.00	12.94	4.83	12.43	4.66	11.40	4.30
	-9.5	-10	15.60	5.40	14.57	5.06	13.54	4.79	12.94	4.62	12.43	4.46	11.40	4.07
	-8.5	-9.1	15.60	5.17	14.57	4.88	13.54	4.59	12.94	4.42	12.43	4.25	11.40	3.84
	-7	-7.6	15.60	4.98	14.57	4.67	13.54	4.43	12.94	4.27	12.43	4.09	11.40	3.67
	-5	-5.6	15.60	4.79	14.57	4.50	13.54	4.21	12.94	4.09	12.43	3.93	11.40	3.50
	-3	-3.7	15.60	4.63	14.57	4.32	13.54	4.02	12.94	3.93	12.43	3.76	11.40	3.37
	0	-0.7	15.60	4.44	14.57	4.15	13.54	3.84	12.94	3.74	12.43	3.58	11.40	3.31
	3	2.2	15.60	4.24	14.57	3.95	13.54	3.70	12.94	3.59	12.43	3.40	11.40	3.29
	5	4.1	15.60	4.02	14.57	3.78	13.54	3.56	12.94	3.43	12.43	3.33	11.40	3.26
7	6	15.60	3.84	14.57	3.62	13.54	3.39	12.94	3.29	12.43	3.28	11.40	3.16	
9	7.9	15.60	3.77	14.57	3.54	13.54	3.34	12.94	3.21	12.43	3.14	11.40	3.06	
11	9.8	15.60	3.72	14.57	3.49	13.54	3.25	12.94	3.14	12.43	3.08	11.40	3.01	
13	11.8	15.60	3.60	14.57	3.37	13.54	3.15	12.94	3.07	12.43	3.02	11.40	2.94	
15	13.7	15.60	3.56	14.57	3.30	13.54	3.06	12.94	2.99	12.43	2.93	11.40	2.86	

Abbreviations:

CR: Combination ratio

TC: Total capacity (kW)

PI: Power input (compressor + outdoor fan motor) (kW)

Notes:

Shaded cells indicate rating condition.

Table 2-8.15: 10HP heating capacity

CR	Outdoor air temp.		Indoor air temp. °C DB											
			16		18		20		21		22		24	
	°C DB	°C WB	TC kW	PI kW	TC kW	PI kW	TC kW	PI kW	TC kW	PI kW	TC kW	PI kW	TC kW	PI kW
130%	-25	-25.4	24.57	7.42	24.47	7.55	23.96	7.85	23.88	8.07	23.86	8.29	23.72	8.42
	-19.8	-20	25.83	7.61	25.73	7.78	25.63	8.17	25.53	8.39	25.53	8.61	25.43	8.72
	-18.8	-19	26.03	7.75	25.93	7.88	25.83	8.24	25.83	8.46	25.73	8.69	25.63	8.77
	-16.7	-17	26.43	7.84	26.33	8.02	26.23	8.33	26.23	8.55	26.13	8.78	26.03	8.92
	-13.7	-15	26.83	7.93	26.73	8.14	26.63	8.48	26.63	8.70	26.53	8.92	26.43	9.04
	-11.8	-13	27.22	8.06	27.13	8.27	27.03	8.64	27.03	8.86	26.93	9.08	26.93	9.18
	-9.8	-11	27.62	8.19	27.52	8.42	27.42	8.73	27.42	8.95	27.42	9.17	27.32	9.19
	-9.5	-10	27.82	8.31	27.72	8.50	27.72	8.86	27.62	9.08	27.62	9.31	27.52	9.33
	-8.5	-9.1	28.02	8.42	27.92	8.62	27.82	8.96	27.82	9.18	27.82	9.40	27.72	9.44
	-7	-7.6	28.32	8.43	28.22	8.74	28.22	9.04	28.12	9.25	28.12	9.54	28.02	9.56
	-5	-5.6	30.52	8.80	30.42	8.99	30.32	9.33	30.32	9.61	30.22	9.60	30.12	9.67
	-3	-3.7	30.91	9.01	30.81	9.14	30.72	9.48	30.72	9.76	30.62	9.72	30.52	9.80
	0	-0.7	31.51	9.28	31.41	9.22	31.31	9.60	31.31	9.86	31.21	9.87	31.21	9.87
	3	2.2	34.81	9.81	34.40	9.82	34.31	10.10	34.21	10.28	34.21	10.39	34.11	10.47
	5	4.1	43.28	11.85	41.55	11.71	40.89	11.66	39.29	11.29	37.70	11.17	34.60	10.68
7	6	43.98	11.95	42.34	11.40	40.89	11.09	39.29	10.81	37.70	10.70	34.60	10.31	
9	7.9	43.98	11.36	42.34	10.85	40.89	10.76	39.29	10.61	37.70	10.43	34.60	10.08	
11	9.8	43.98	10.81	42.34	10.41	40.89	10.39	39.29	10.25	37.70	10.12	34.60	9.69	
13	11.8	43.98	10.29	42.34	10.10	40.89	10.10	39.29	10.08	37.70	9.90	34.60	9.52	
15	13.7	43.98	9.97	42.34	9.87	40.89	9.82	39.29	9.68	37.70	9.62	34.60	9.17	
120%	-25	-25.4	24.33	8.08	24.23	8.38	24.21	8.67	24.13	8.88	24.02	9.09	23.95	9.22
	-19.8	-20	25.80	8.30	25.70	8.58	25.60	8.83	25.60	9.04	25.50	9.25	25.40	9.41
	-18.8	-19	26.00	8.42	25.90	8.59	25.80	8.98	25.80	9.19	25.70	9.40	25.60	9.51
	-16.7	-17	26.40	8.54	26.30	8.72	26.20	9.10	26.20	9.31	26.10	9.52	26.10	9.55
	-13.7	-15	26.80	8.65	26.70	8.89	26.60	9.14	26.60	9.35	26.60	9.56	26.50	9.64
	-11.8	-13	27.20	8.78	27.10	8.99	27.04	9.26	27.00	9.47	27.00	9.68	26.90	9.75
	-9.8	-11	27.60	8.83	27.50	9.05	27.50	9.37	27.40	9.58	27.40	9.79	27.30	9.93
	-9.5	-10	27.80	8.93	27.70	9.12	27.70	9.43	27.60	9.64	27.60	9.85	27.50	10.06
	-8.5	-9.1	28.00	9.02	27.90	9.23	27.90	9.54	27.80	9.75	27.80	9.96	27.70	10.06
	-7	-7.6	28.30	9.18	28.20	9.40	28.20	9.64	28.10	9.85	28.10	10.06	28.00	10.18
	-5	-5.6	30.50	9.25	30.40	9.48	30.30	9.74	30.30	9.95	30.30	10.16	30.20	10.35
	-3	-3.7	30.90	9.42	30.80	9.63	30.70	9.87	30.70	10.08	30.60	10.29	30.60	10.41
	0	-0.7	31.50	9.53	31.40	9.76	31.30	9.95	31.30	10.16	31.30	10.37	31.20	10.48
	3	2.2	34.40	10.11	34.40	10.38	34.30	10.46	34.20	10.67	34.20	10.88	32.00	10.37
	5	4.1	43.30	11.34	40.70	11.22	37.80	11.04	36.30	10.81	34.90	10.70	32.00	10.06
7	6	43.60	11.26	40.70	10.75	37.80	10.48	36.30	10.29	34.90	10.23	32.00	9.81	
9	7.9	43.60	10.77	40.70	10.27	37.80	10.16	36.30	9.96	34.90	9.94	32.00	9.51	
11	9.8	43.60	10.42	40.70	10.05	37.80	9.81	36.30	9.66	34.90	9.58	32.00	9.16	
13	11.8	43.60	10.16	40.70	9.80	37.80	9.54	36.30	9.51	34.90	9.40	32.00	8.98	
15	13.7	43.60	9.94	40.70	9.51	37.80	9.27	36.30	9.16	34.90	9.09	32.00	8.65	
110%	-25	-25.4	24.63	8.32	24.52	8.51	24.40	8.71	24.43	8.57	24.35	8.74	24.33	8.97
	-19.8	-20	25.70	8.44	25.60	8.63	25.50	8.83	25.50	8.69	25.40	8.86	25.40	9.08
	-18.8	-19	25.90	8.57	25.80	8.76	25.70	8.95	25.70	8.70	25.60	8.95	25.60	9.11
	-16.7	-17	26.30	8.69	26.20	8.88	26.10	9.08	26.10	8.87	26.10	9.06	26.00	9.23
	-13.7	-15	26.70	8.77	26.60	8.96	26.50	9.15	26.50	8.93	26.50	9.10	26.40	9.32
	-11.8	-13	27.10	8.90	27.00	9.09	27.00	9.28	26.90	9.02	26.90	9.21	26.80	9.43
	-9.8	-11	27.50	8.90	27.40	9.09	27.40	9.28	27.30	9.18	27.30	9.32	27.20	9.55
	-9.5	-10	27.70	9.00	27.70	9.19	27.60	9.38	27.50	9.22	27.50	9.43	27.40	9.65
	-8.5	-9.1	27.90	9.09	27.80	9.29	27.80	9.48	27.70	9.30	27.70	9.52	27.60	9.76
	-7	-7.6	28.20	9.19	28.10	9.38	28.10	9.58	28.00	9.44	28.00	9.63	27.90	9.79
	-5	-5.6	30.40	9.31	30.30	9.51	30.20	9.70	30.20	9.53	30.20	9.69	29.30	9.68
	-3	-3.7	30.80	9.38	30.70	9.57	30.60	9.77	30.60	9.61	30.60	9.81	29.30	9.52
	0	-0.7	31.40	9.61	31.30	9.80	31.30	9.99	31.20	9.69	31.20	9.90	29.30	9.38
	3	2.2	34.30	10.04	34.30	10.23	34.20	10.42	33.30	10.08	32.00	9.98	29.30	9.30
	5	4.1	40.00	10.95	37.30	10.92	34.70	10.19	33.30	9.90	32.00	9.72	29.30	9.27
7	6	40.00	10.55	37.30	10.29	34.70	9.67	33.30	9.41	32.00	9.27	29.30	9.03	
9	7.9	40.00	10.07	37.30	9.73	34.70	9.33	33.30	9.18	32.00	9.08	29.30	8.88	
11	9.8	40.00	9.71	37.30	9.38	34.70	9.06	33.30	8.85	32.00	8.78	29.30	8.58	
13	11.8	40.00	9.42	37.30	9.08	34.70	8.77	33.30	8.59	32.00	8.48	29.30	8.29	
15	13.7	40.00	9.15	37.30	8.78	34.70	8.48	33.30	8.29	32.00	8.20	29.30	8.00	

Abbreviations:

CR: Combination ratio

TC: Total capacity (kW)

PI: Power input (compressor + outdoor fan motor) (kW)

Notes:

Shaded cells indicate rating condition.

Table 2-8.15: 10HP heating capacity (continued)

CR	Outdoor air temp.		Indoor air temp. °C DB											
			16		18		20		21		22		24	
	°C DB	°C WB	TC	PI	TC	PI	TC	PI	TC	PI	TC	PI	TC	PI
100%	-25	-25.4	24.66	10.39	24.56	10.49	24.46	10.56	24.46	10.67	24.46	10.74	24.36	10.87
	-19.8	-20	25.80	10.39	25.70	10.51	25.60	10.62	25.60	10.68	25.60	10.75	25.50	10.80
	-18.8	-19	26.20	10.42	26.10	10.53	26.00	10.65	26.00	10.70	26.00	10.76	25.90	10.71
	-16.7	-17	26.60	10.43	26.50	10.55	26.50	10.66	26.40	10.72	26.40	10.79	26.30	10.66
	-13.7	-15	27.00	10.46	26.90	10.56	26.90	10.68	26.80	10.74	26.80	10.80	26.70	10.53
	-11.8	-13	27.40	10.47	27.30	10.58	27.30	10.70	27.20	10.76	27.20	10.81	26.70	10.42
	-9.8	-11	27.60	10.48	27.60	10.60	27.50	10.71	27.50	10.76	27.40	10.82	26.70	10.40
	-9.5	-10	27.80	10.49	27.70	10.60	27.70	10.74	27.60	10.77	27.60	10.84	26.70	10.31
	-8.5	-9.1	28.10	10.51	28.10	10.61	28.00	10.77	27.90	10.79	27.90	10.85	26.70	10.16
	-7	-7.6	30.30	10.52	30.20	10.61	30.20	10.99	30.10	11.18	29.10	10.63	26.70	10.12
	-5	-5.6	30.70	10.53	30.60	10.62	30.60	10.73	30.30	10.86	29.10	10.32	26.70	9.84
	-3	-3.7	31.30	10.55	31.20	10.63	31.20	10.38	30.30	10.24	29.10	9.99	26.70	9.51
	0	-0.7	32.10	10.56	33.90	10.63	31.50	10.09	30.30	9.77	29.10	9.50	26.70	9.10
	3	2.2	34.20	10.35	33.90	10.37	31.50	9.80	30.30	9.30	29.10	8.93	26.70	8.65
	5	4.1	36.30	10.18	33.90	9.86	31.50	9.34	30.30	8.88	29.10	8.57	26.70	8.27
7	6	36.30	10.06	33.90	9.35	31.50	8.75	30.30	8.40	29.10	8.22	26.70	7.90	
9	7.9	36.30	9.48	33.90	8.86	31.50	8.50	30.30	8.20	29.10	7.98	26.70	7.65	
11	9.8	36.30	8.87	33.90	8.31	31.50	8.22	30.30	7.87	29.10	7.69	26.70	7.33	
13	11.8	36.30	8.31	33.90	8.11	31.50	7.90	30.30	7.59	29.10	7.42	26.70	7.08	
15	13.7	36.30	7.91	33.90	7.77	31.50	7.61	30.30	7.32	29.10	7.15	26.70	6.80	
90%	-25	-25.4	24.47	10.38	24.33	10.48	24.25	10.60	24.23	10.74	24.23	10.77	24.00	10.10
	-19.8	-20	25.50	10.56	25.40	10.66	25.30	10.77	25.30	10.84	25.30	10.90	24.00	9.89
	-18.8	-19	25.70	10.57	25.60	10.67	25.50	10.79	25.50	10.85	25.50	10.86	24.00	9.78
	-16.7	-17	26.10	10.58	26.00	10.68	26.00	10.80	25.90	10.86	25.90	10.65	24.00	9.58
	-13.7	-15	26.50	10.60	26.40	10.71	26.40	10.82	26.30	10.87	26.20	10.43	24.00	9.39
	-11.8	-13	26.90	10.62	26.80	10.72	26.80	10.84	26.70	10.74	26.20	10.22	24.00	9.21
	-9.8	-11	27.30	10.63	27.30	10.75	27.20	10.85	27.20	10.52	26.20	10.03	24.00	9.04
	-9.5	-10	27.50	10.65	27.50	10.75	27.40	10.86	27.30	10.42	26.20	9.92	24.00	8.95
	-8.5	-9.1	27.70	10.66	27.60	10.76	27.60	10.84	27.30	10.33	26.20	9.84	24.00	8.87
	-7	-7.6	28.00	10.67	28.00	10.62	27.90	10.68	27.30	10.19	26.20	9.70	24.00	8.75
	-5	-5.6	30.20	10.69	30.10	10.16	28.40	10.24	27.30	9.85	26.20	9.39	24.00	8.49
	-3	-3.7	30.60	10.71	30.50	9.71	28.40	9.73	27.30	9.48	26.20	9.09	24.00	8.28
	0	-0.7	31.20	10.72	30.50	9.22	28.40	9.31	27.30	9.03	26.20	8.65	24.00	8.06
	3	2.2	32.70	10.73	30.50	8.74	28.40	8.79	27.30	8.69	26.20	8.26	24.00	7.79
	5	4.1	32.70	10.47	30.50	8.31	28.40	8.39	27.30	8.24	26.20	7.87	24.00	7.48
7	6	32.70	9.10	30.50	8.15	28.40	7.85	27.30	7.54	26.20	7.25	24.00	6.65	
9	7.9	32.70	8.54	30.50	8.00	28.40	7.45	27.30	7.19	26.20	6.92	24.00	6.40	
11	9.8	32.70	8.05	30.50	7.57	28.40	7.10	27.30	6.86	26.20	6.63	24.00	6.17	
13	11.8	32.70	7.60	30.50	7.19	28.40	6.78	27.30	6.58	26.20	6.38	24.00	5.97	
15	13.7	32.70	7.29	30.50	6.92	28.40	6.55	27.30	6.38	26.20	6.20	24.00	5.83	
80%	-25	-25.4	24.43	11.01	24.33	11.15	24.44	10.81	24.20	10.30	23.30	9.86	21.30	8.94
	-19.8	-20	25.40	10.60	25.30	10.71	25.20	10.35	24.20	9.88	23.30	9.41	21.30	8.50
	-18.8	-19	25.60	10.61	25.50	10.71	25.20	10.25	24.20	9.77	23.30	9.31	21.30	8.41
	-16.7	-17	26.00	10.63	25.90	10.74	25.20	10.04	24.20	9.57	23.30	9.12	21.30	8.24
	-13.7	-15	26.40	10.65	26.30	10.75	25.20	9.84	24.20	9.39	23.30	8.95	21.30	8.09
	-11.8	-13	26.80	10.66	26.70	10.55	25.20	9.64	24.20	9.20	23.30	8.77	21.30	7.94
	-9.8	-11	27.20	10.68	27.10	10.34	25.20	9.46	24.20	9.02	23.30	8.61	21.30	7.78
	-9.5	-10	27.40	10.69	27.10	10.24	25.20	9.36	24.20	8.94	23.30	8.52	21.30	7.71
	-8.5	-9.1	27.60	10.70	27.10	10.15	25.20	9.29	24.20	8.86	23.30	8.45	21.30	7.65
	-7	-7.6	27.90	10.71	27.10	10.00	25.20	9.16	24.20	8.75	23.30	8.34	21.30	7.55
	-5	-5.6	29.10	10.50	27.10	9.67	25.20	8.87	24.20	8.47	23.30	8.10	21.30	7.33
	-3	-3.7	29.10	10.86	27.10	9.32	25.20	8.50	24.20	8.15	23.30	7.80	21.30	7.13
	0	-0.7	29.10	10.72	27.10	8.89	25.20	8.20	24.20	7.91	23.30	7.57	21.30	6.96
	3	2.2	29.10	9.91	27.10	8.39	25.20	7.74	24.20	7.63	23.30	7.28	21.30	6.69
	5	4.1	29.10	9.06	27.10	7.93	25.20	7.38	24.20	7.32	23.30	6.94	21.30	6.55
7	6	29.10	7.95	27.10	7.42	25.20	6.90	24.20	6.63	23.30	6.38	21.30	5.88	
9	7.9	29.10	7.53	27.10	7.07	25.20	6.61	24.20	6.38	23.30	6.15	21.30	5.71	
11	9.8	29.10	7.16	27.10	6.75	25.20	6.35	24.20	6.15	23.30	5.95	21.30	5.56	
13	11.8	29.10	6.83	27.10	6.47	25.20	6.12	24.20	5.95	23.30	5.77	21.30	5.42	
15	13.7	29.10	6.60	27.10	6.27	25.20	5.96	24.20	5.81	23.30	5.64	21.30	5.33	

Abbreviations:

CR: Combination ratio

TC: Total capacity (kW)

PI: Power input (compressor + outdoor fan motor) (kW)

Notes:
Shaded cells indicate rating condition.

Table 2-8.15: 10HP heating capacity (continued)

CR	Outdoor air temp.		Indoor air temp. °C DB											
			16		18		20		21		22		24	
	°C DB	°C WB	TC kW	PI kW	TC kW	PI kW	TC kW	PI kW	TC kW	PI kW	TC kW	PI kW	TC kW	PI kW
70%	-25	-25.4	25.20	11.14	23.70	10.30	22.10	10.13	21.20	9.94	20.40	9.82	18.70	9.45
	-19.8	-20	25.20	10.61	23.70	9.76	22.10	9.56	21.20	9.38	20.40	9.26	18.70	8.89
	-18.8	-19	25.40	10.49	23.70	9.66	22.10	9.46	21.20	9.28	20.40	9.15	18.70	8.79
	-16.7	-17	25.40	10.28	23.70	9.47	22.10	9.30	21.20	9.11	20.40	8.99	18.70	8.62
	-13.7	-15	25.40	10.08	23.70	9.28	22.10	9.12	21.20	8.94	20.40	8.81	18.70	8.44
	-11.8	-13	25.40	9.87	23.70	9.10	22.10	8.97	21.20	8.78	20.40	8.66	18.70	8.29
	-9.8	-11	25.40	9.68	23.70	8.92	22.10	8.80	21.20	8.62	20.40	8.50	18.70	8.13
	-9.5	-10	25.40	9.59	23.70	8.85	22.10	8.58	21.20	8.40	20.40	8.27	18.70	7.90
	-8.5	-9.1	25.40	9.51	23.70	8.77	22.10	8.29	21.20	8.11	20.40	7.99	18.70	7.62
	-7	-7.6	25.40	9.38	23.70	8.64	22.10	7.93	21.20	7.75	20.40	7.63	18.70	7.26
	-5	-5.6	25.40	9.09	23.70	8.39	22.10	7.72	21.20	7.53	20.40	7.41	18.70	7.04
	-3	-3.7	25.40	8.60	23.70	8.14	22.10	7.49	21.20	7.31	20.40	7.19	18.70	6.82
	0	-0.7	25.40	8.14	23.70	7.78	22.10	7.17	21.20	6.99	20.40	6.87	18.70	6.50
	3	2.2	25.40	7.68	23.70	7.36	22.10	6.74	21.20	6.55	20.40	6.43	18.70	6.06
	5	4.1	25.40	7.33	23.70	6.89	22.10	6.48	21.20	6.30	20.40	6.18	18.70	5.81
60%	-25	-25.4	21.80	10.38	20.40	9.82	18.90	9.36	18.20	9.15	17.40	8.77	16.00	8.31
	-19.8	-20	21.80	9.83	20.40	9.37	18.90	9.01	18.20	8.75	17.40	8.36	16.00	7.88
	-18.8	-19	21.80	9.58	20.40	9.04	18.90	8.69	18.20	8.46	17.40	8.03	16.00	7.60
	-16.7	-17	21.80	9.28	20.40	8.76	18.90	8.42	18.20	8.13	17.40	7.73	16.00	7.30
	-13.7	-15	21.80	8.96	20.40	8.50	18.90	8.16	18.20	7.83	17.40	7.43	16.00	6.99
	-11.8	-13	21.80	8.64	20.40	8.19	18.90	7.85	18.20	7.56	17.40	7.11	16.00	6.68
	-9.8	-11	21.80	8.36	20.40	7.88	18.90	7.47	18.20	7.21	17.40	6.81	16.00	6.43
	-9.5	-10	21.80	8.07	20.40	7.57	18.90	7.16	18.20	6.91	17.40	6.51	16.00	6.08
	-8.5	-9.1	21.80	7.73	20.40	7.29	18.90	6.86	18.20	6.61	17.40	6.21	16.00	5.74
	-7	-7.6	21.80	7.44	20.40	6.98	18.90	6.63	18.20	6.39	17.40	5.97	16.00	5.49
	-5	-5.6	21.80	7.17	20.40	6.73	18.90	6.30	18.20	6.12	17.40	5.73	16.00	5.23
	-3	-3.7	21.80	6.92	20.40	6.46	18.90	6.02	18.20	5.88	17.40	5.48	16.00	5.04
	0	-0.7	21.80	6.64	20.40	6.20	18.90	5.75	18.20	5.59	17.40	5.20	16.00	4.95
	3	2.2	21.80	6.34	20.40	5.91	18.90	5.53	18.20	5.37	17.40	4.94	16.00	4.77
	5	4.1	21.80	6.01	20.40	5.65	18.90	5.32	18.20	5.13	17.40	4.83	16.00	4.66
50%	-25	-25.4	18.20	8.60	17.00	8.13	15.80	7.75	15.10	7.57	14.50	7.38	13.30	6.88
	-19.8	-20	18.20	8.14	17.00	7.75	15.80	7.46	15.10	7.24	14.50	7.04	13.30	6.52
	-18.8	-19	18.20	7.93	17.00	7.49	15.80	7.19	15.10	7.00	14.50	6.77	13.30	6.29
	-16.7	-17	18.20	7.68	17.00	7.26	15.80	6.97	15.10	6.73	14.50	6.52	13.30	6.04
	-13.7	-15	18.20	7.42	17.00	7.04	15.80	6.75	15.10	6.48	14.50	6.27	13.30	5.79
	-11.8	-13	18.20	7.16	17.00	6.78	15.80	6.49	15.10	6.26	14.50	6.01	13.30	5.53
	-9.8	-11	18.20	6.92	17.00	6.53	15.80	6.18	15.10	5.97	14.50	5.76	13.30	5.33
	-9.5	-10	18.20	6.68	17.00	6.26	15.80	5.93	15.10	5.72	14.50	5.52	13.30	5.04
	-8.5	-9.1	18.20	6.40	17.00	6.04	15.80	5.68	15.10	5.47	14.50	5.27	13.30	4.75
	-7	-7.6	18.20	6.16	17.00	5.78	15.80	5.49	15.10	5.29	14.50	5.07	13.30	4.54
	-5	-5.6	18.20	5.93	17.00	5.57	15.80	5.21	15.10	5.07	14.50	4.87	13.30	4.33
	-3	-3.7	18.20	5.73	17.00	5.35	15.80	4.98	15.10	4.87	14.50	4.66	13.30	4.17
	0	-0.7	18.20	5.50	17.00	5.14	15.80	4.76	15.10	4.63	14.50	4.43	13.30	4.09
	3	2.2	18.20	5.25	17.00	4.89	15.80	4.58	15.10	4.44	14.50	4.21	13.30	4.07
	5	4.1	18.20	4.98	17.00	4.68	15.80	4.41	15.10	4.24	14.50	4.12	13.30	4.03
7	6	18.20	4.75	17.00	4.48	15.80	4.20	15.10	4.07	14.50	4.06	13.30	3.91	
9	7.9	18.20	4.67	17.00	4.38	15.80	4.13	15.10	3.98	14.50	3.89	13.30	3.79	
11	9.8	18.20	4.60	17.00	4.32	15.80	4.03	15.10	3.88	14.50	3.82	13.30	3.72	
13	11.8	18.20	4.46	17.00	4.17	15.80	3.90	15.10	3.80	14.50	3.73	13.30	3.64	
15	13.7	18.20	4.40	17.00	4.09	15.80	3.79	15.10	3.71	14.50	3.63	13.30	3.54	

Abbreviations:
CR: Combination ratio
TC: Total capacity (kW)

PI: Power input (compressor + outdoor fan motor) (kW)

Notes:

Shaded cells indicate rating condition.

Table 2-8.16: 12HP heating capacity

CR	Outdoor air temp.		Indoor air temp. °C DB											
			16		18		20		21		22		24	
	°C DB	°C WB	TC kW	PI kW	TC kW	PI kW	TC kW	PI kW	TC kW	PI kW	TC kW	PI kW	TC kW	PI kW
130%	-25	-25.4	29.25	9.85	29.13	10.02	28.53	10.42	28.43	10.71	28.41	11.01	28.24	11.18
	-19.8	-20	30.75	10.11	30.63	10.32	30.51	10.84	30.39	11.14	30.39	11.43	30.27	11.58
	-18.8	-19	30.99	10.29	30.87	10.46	30.75	10.94	30.75	11.24	30.63	11.53	30.51	11.64
	-16.7	-17	31.46	10.41	31.34	10.65	31.22	11.06	31.22	11.36	31.10	11.65	30.99	11.84
	-13.7	-15	31.94	10.53	31.82	10.81	31.70	11.26	31.70	11.55	31.58	11.85	31.46	12.01
	-11.8	-13	32.41	10.71	32.29	10.98	32.17	11.47	32.17	11.76	32.05	12.06	32.05	12.19
	-9.8	-11	32.89	10.87	32.77	11.18	32.65	11.59	32.65	11.88	32.65	12.18	32.53	12.20
	-9.5	-10	33.12	11.03	33.00	11.29	33.00	11.77	32.89	12.06	32.89	12.36	32.77	12.39
	-8.5	-9.1	33.36	11.18	33.24	11.45	33.12	11.90	33.12	12.19	33.12	12.49	33.00	12.53
	-7	-7.6	33.72	11.20	33.60	11.61	33.60	12.01	33.48	12.29	33.48	12.66	33.36	12.69
	-5	-5.6	36.33	11.69	36.21	11.94	36.09	12.38	36.09	12.76	35.97	12.74	35.85	12.84
	-3	-3.7	36.80	11.97	36.68	12.13	36.57	12.59	36.57	12.96	36.45	12.91	36.33	13.01
	0	-0.7	37.52	12.32	37.40	12.25	37.28	12.74	37.28	13.10	37.16	13.11	37.16	13.11
	3	2.2	41.44	13.02	40.96	13.04	40.84	13.41	40.72	13.66	40.72	13.79	40.60	13.91
	5	4.1	51.52	15.74	49.46	15.55	48.68	15.49	46.78	14.99	44.88	14.83	41.20	14.18
	7	6	52.36	15.86	50.41	15.13	48.68	14.73	46.78	14.35	44.88	14.21	41.20	13.70
9	7.9	52.36	15.09	50.41	14.41	48.68	14.28	46.78	14.09	44.88	13.85	41.20	13.38	
11	9.8	52.36	14.36	50.41	13.82	48.68	13.79	46.78	13.61	44.88	13.44	41.20	12.87	
13	11.8	52.36	13.66	50.41	13.41	48.68	13.41	46.78	13.38	44.88	13.15	41.20	12.64	
15	13.7	52.36	13.23	50.41	13.11	48.68	13.04	46.78	12.86	44.88	12.77	41.20	12.17	
120%	-25	-25.4	28.97	10.73	28.85	11.12	28.82	11.51	28.73	11.79	28.60	12.07	28.51	12.24
	-19.8	-20	30.71	11.02	30.60	11.39	30.48	11.72	30.48	12.00	30.36	12.28	30.24	12.49
	-18.8	-19	30.95	11.18	30.83	11.41	30.71	11.92	30.71	12.20	30.60	12.48	30.48	12.63
	-16.7	-17	31.43	11.35	31.31	11.58	31.19	12.08	31.19	12.36	31.07	12.64	31.07	12.67
	-13.7	-15	31.90	11.49	31.79	11.81	31.67	12.14	31.67	12.42	31.67	12.70	31.55	12.80
	-11.8	-13	32.38	11.66	32.26	11.93	32.20	12.30	32.14	12.58	32.14	12.86	32.02	12.94
	-9.8	-11	32.86	11.72	32.74	12.02	32.74	12.44	32.62	12.72	32.62	12.99	32.50	13.19
	-9.5	-10	33.10	11.86	32.98	12.11	32.98	12.52	32.86	12.80	32.86	13.08	32.74	13.35
	-8.5	-9.1	33.33	11.97	33.21	12.26	33.21	12.66	33.10	12.94	33.10	13.22	32.98	13.36
	-7	-7.6	33.69	12.19	33.57	12.48	33.57	12.81	33.45	13.08	33.45	13.36	33.33	13.52
	-5	-5.6	36.31	12.29	36.19	12.58	36.07	12.94	36.07	13.22	36.07	13.50	35.95	13.75
	-3	-3.7	36.79	12.50	36.67	12.79	36.55	13.11	36.55	13.38	36.43	13.66	36.43	13.82
	0	-0.7	37.50	12.66	37.38	12.96	37.26	13.22	37.26	13.50	37.26	13.77	37.14	13.91
	3	2.2	40.95	13.43	40.95	13.78	40.83	13.89	40.71	14.17	40.71	14.45	38.10	13.77
	5	4.1	51.55	15.05	48.45	14.90	45.00	14.65	43.21	14.36	41.55	14.20	38.10	13.36
	7	6	51.90	14.95	48.45	14.27	45.00	13.91	43.21	13.67	41.55	13.59	38.10	13.03
9	7.9	51.90	14.30	48.45	13.64	45.00	13.49	43.21	13.22	41.55	13.20	38.10	12.63	
11	9.8	51.90	13.83	48.45	13.35	45.00	13.03	43.21	12.83	41.55	12.72	38.10	12.16	
13	11.8	51.90	13.50	48.45	13.01	45.00	12.66	43.21	12.63	41.55	12.49	38.10	11.92	
15	13.7	51.90	13.20	48.45	12.62	45.00	12.31	43.21	12.17	41.55	12.07	38.10	11.48	
110%	-25	-25.4	29.33	11.05	29.19	11.30	29.05	11.56	29.09	11.38	28.98	11.60	28.97	11.91
	-19.8	-20	30.60	11.20	30.48	11.46	30.36	11.72	30.36	11.54	30.24	11.76	30.24	12.05
	-18.8	-19	30.83	11.37	30.71	11.63	30.60	11.89	30.60	11.56	30.48	11.89	30.48	12.09
	-16.7	-17	31.31	11.54	31.19	11.79	31.07	12.05	31.07	11.78	31.07	12.03	30.95	12.25
	-13.7	-15	31.79	11.64	31.67	11.90	31.55	12.15	31.55	11.85	31.55	12.08	31.43	12.38
	-11.8	-13	32.26	11.81	32.14	12.07	32.14	12.33	32.02	11.97	32.02	12.23	31.90	12.52
	-9.8	-11	32.74	11.81	32.62	12.07	32.62	12.33	32.50	12.19	32.50	12.37	32.38	12.69
	-9.5	-10	32.98	11.94	32.98	12.20	32.86	12.46	32.74	12.24	32.74	12.52	32.62	12.81
	-8.5	-9.1	33.21	12.07	33.10	12.33	33.10	12.59	32.98	12.35	32.98	12.65	32.86	12.96
	-7	-7.6	33.57	12.20	33.45	12.46	33.45	12.72	33.33	12.53	33.33	12.79	33.21	13.00
	-5	-5.6	36.19	12.37	36.07	12.62	35.95	12.88	35.95	12.66	35.95	12.86	34.88	12.86
	-3	-3.7	36.67	12.46	36.55	12.71	36.43	12.97	36.43	12.76	36.43	13.03	34.88	12.64
	0	-0.7	37.38	12.76	37.26	13.01	37.26	13.27	37.14	12.87	37.14	13.15	34.88	12.46
	3	2.2	40.83	13.33	40.83	13.58	40.71	13.84	39.64	13.38	38.10	13.25	34.88	12.35
	5	4.1	47.62	14.54	44.40	14.50	41.31	13.53	39.64	13.14	38.10	12.91	34.88	12.30
	7	6	47.62	14.01	44.40	13.66	41.31	12.84	39.64	12.50	38.10	12.31	34.88	11.99
9	7.9	47.62	13.37	44.40	12.92	41.31	12.38	39.64	12.19	38.10	12.05	34.88	11.79	
11	9.8	47.62	12.89	44.40	12.45	41.31	12.03	39.64	11.75	38.10	11.66	34.88	11.40	
13	11.8	47.62	12.51	44.40	12.06	41.31	11.65	39.64	11.40	38.10	11.26	34.88	11.01	

MDV6 VRF 50Hz



	15	13.7	47.62	12.16	44.40	11.66	41.31	11.26	39.64	11.01	38.10	10.88	34.88	10.62
--	----	------	-------	-------	-------	-------	-------	-------	-------	-------	-------	-------	-------	-------

Abbreviations:

CR: Combination ratio

TC: Total capacity (kW)

PI: Power input (compressor + outdoor fan motor) (kW)

Notes:

1. Shaded cells indicate rating condition.

Table continued on next page ...

Table 2-8.16: 12HP heating capacity (continued)

CR	Outdoor air temp.		Indoor air temp. °C DB											
			16		18		20		21		22		24	
	°C DB	°C WB	TC kW	PI kW	TC kW	PI kW	TC kW	PI kW	TC kW	PI kW	TC kW	PI kW	TC kW	PI kW
100%	-25	-25.4	29.35	13.80	29.23	13.93	29.11	14.02	29.11	14.17	29.11	14.25	28.99	14.44
	-19.8	-20	30.71	13.80	30.60	13.95	30.48	14.10	30.48	14.19	30.48	14.27	30.36	14.34
	-18.8	-19	31.19	13.83	31.07	13.99	30.95	14.14	30.95	14.20	30.95	14.29	30.83	14.22
	-16.7	-17	31.67	13.85	31.55	14.00	31.55	14.15	31.43	14.24	31.43	14.32	31.31	14.15
	-13.7	-15	32.14	13.88	32.02	14.02	32.02	14.19	31.90	14.25	31.90	14.34	31.79	13.98
	-11.8	-13	32.62	13.90	32.50	14.05	32.50	14.20	32.38	14.29	32.38	14.36	31.79	13.83
	-9.8	-11	32.86	13.92	32.86	14.07	32.74	14.22	32.74	14.29	32.62	14.37	31.79	13.81
	-9.5	-10	33.10	13.93	32.98	14.07	32.98	14.26	32.86	14.31	32.86	14.39	31.79	13.69
	-8.5	-9.1	33.45	13.95	33.45	14.09	33.33	14.30	33.21	14.32	33.21	14.41	31.79	13.49
	-7	-7.6	36.07	13.97	35.95	14.09	35.95	14.59	35.83	14.84	34.64	14.12	31.79	13.44
	-5	-5.6	36.55	13.99	36.43	14.10	36.43	14.25	36.07	14.42	34.64	13.70	31.79	13.06
	-3	-3.7	37.26	14.00	37.14	14.11	37.14	13.78	36.07	13.59	34.64	13.26	31.79	12.63
	0	-0.7	38.21	14.02	40.36	14.12	37.50	13.40	36.07	12.97	34.64	12.62	31.79	12.08
	3	2.2	40.71	13.74	40.36	13.77	37.50	13.02	36.07	12.34	34.64	11.86	31.79	11.48
	5	4.1	43.21	13.52	40.36	13.09	37.50	12.40	36.07	11.79	34.64	11.38	31.79	10.97
	7	6	43.21	13.35	40.36	12.42	37.50	11.61	36.07	11.16	34.64	10.92	31.79	10.49
	9	7.9	43.21	12.59	40.36	11.76	37.50	11.29	36.07	10.88	34.64	10.60	31.79	10.15
11	9.8	43.21	11.78	40.36	11.04	37.50	10.91	36.07	10.44	34.64	10.21	31.79	9.73	
13	11.8	43.21	11.04	40.36	10.77	37.50	10.49	36.07	10.07	34.64	9.85	31.79	9.40	
15	13.7	43.21	10.50	40.36	10.31	37.50	10.10	36.07	9.72	34.64	9.49	31.79	9.03	
90%	-25	-25.4	29.13	13.79	28.97	13.92	28.87	14.07	28.85	14.26	28.85	14.31	28.57	13.41
	-19.8	-20	30.36	14.02	30.24	14.15	30.12	14.31	30.12	14.39	30.12	14.47	28.57	13.13
	-18.8	-19	30.60	14.04	30.48	14.17	30.36	14.32	30.36	14.41	30.36	14.42	28.57	12.99
	-16.7	-17	31.07	14.05	30.95	14.19	30.95	14.34	30.83	14.42	30.83	14.14	28.57	12.72
	-13.7	-15	31.55	14.07	31.43	14.22	31.43	14.37	31.31	14.44	31.19	13.85	28.57	12.47
	-11.8	-13	32.02	14.10	31.90	14.24	31.90	14.39	31.79	14.25	31.19	13.56	28.57	12.23
	-9.8	-11	32.50	14.12	32.50	14.27	32.38	14.41	32.38	13.97	31.19	13.31	28.57	12.00
	-9.5	-10	32.74	14.14	32.74	14.27	32.62	14.42	32.50	13.83	31.19	13.18	28.57	11.88
	-8.5	-9.1	32.98	14.15	32.86	14.29	32.86	14.39	32.50	13.72	31.19	13.06	28.57	11.78
	-7	-7.6	33.33	14.17	33.33	14.10	33.21	14.19	32.50	13.53	31.19	12.87	28.57	11.61
	-5	-5.6	35.95	14.19	35.83	13.49	33.81	13.59	32.50	13.08	31.19	12.47	28.57	11.28
	-3	-3.7	36.43	14.21	36.31	12.89	33.81	12.92	32.50	12.59	31.19	12.07	28.57	10.99
	0	-0.7	37.14	14.23	36.31	12.25	33.81	12.37	32.50	11.99	31.19	11.48	28.57	10.71
	3	2.2	38.93	14.25	36.31	11.60	33.81	11.67	32.50	11.54	31.19	10.96	28.57	10.34
	5	4.1	38.93	13.90	36.31	11.03	33.81	11.14	32.50	10.94	31.19	10.46	28.57	9.93
	7	6	38.93	12.08	36.31	10.83	33.81	10.42	32.50	10.01	31.19	9.63	28.57	8.84
	9	7.9	38.93	11.34	36.31	10.62	33.81	9.90	32.50	9.54	31.19	9.19	28.57	8.50
11	9.8	38.93	10.69	36.31	10.05	33.81	9.42	32.50	9.10	31.19	8.80	28.57	8.20	
13	11.8	38.93	10.10	36.31	9.54	33.81	9.00	32.50	8.73	31.19	8.47	28.57	7.93	
15	13.7	38.93	9.68	36.31	9.19	33.81	8.70	32.50	8.47	31.19	8.23	28.57	7.74	
80%	-25	-25.4	29.08	14.62	28.96	14.80	29.10	14.35	28.81	13.67	27.74	13.09	25.36	11.87
	-19.8	-20	30.24	14.08	30.12	14.23	30.00	13.74	28.81	13.11	27.74	12.50	25.36	11.28
	-18.8	-19	30.48	14.09	30.36	14.23	30.00	13.61	28.81	12.98	27.74	12.36	25.36	11.17
	-16.7	-17	30.95	14.11	30.83	14.26	30.00	13.33	28.81	12.71	27.74	12.12	25.36	10.94
	-13.7	-15	31.43	14.14	31.31	14.28	30.00	13.06	28.81	12.46	27.74	11.88	25.36	10.74
	-11.8	-13	31.90	14.16	31.79	14.01	30.00	12.80	28.81	12.21	27.74	11.65	25.36	10.54
	-9.8	-11	32.38	14.18	32.26	13.73	30.00	12.56	28.81	11.98	27.74	11.43	25.36	10.34
	-9.5	-10	32.62	14.19	32.26	13.59	30.00	12.43	28.81	11.87	27.74	11.32	25.36	10.24
	-8.5	-9.1	32.86	14.21	32.26	13.48	30.00	12.33	28.81	11.77	27.74	11.22	25.36	10.15
	-7	-7.6	33.21	14.23	32.26	13.28	30.00	12.16	28.81	11.62	27.74	11.07	25.36	10.02
	-5	-5.6	34.64	13.94	32.26	12.85	30.00	11.78	28.81	11.25	27.74	10.75	25.36	9.74
	-3	-3.7	34.64	14.43	32.26	12.38	30.00	11.28	28.81	10.83	27.74	10.36	25.36	9.46
	0	-0.7	34.64	14.24	32.26	11.81	30.00	10.89	28.81	10.51	27.74	10.05	25.36	9.24
	3	2.2	34.64	13.16	32.26	11.14	30.00	10.27	28.81	10.14	27.74	9.67	25.36	8.88
	5	4.1	34.64	12.03	32.26	10.53	30.00	9.80	28.81	9.72	27.74	9.21	25.36	8.69
	7	6	34.64	10.55	32.26	9.85	30.00	9.16	28.81	8.81	27.74	8.48	25.36	7.81
	9	7.9	34.64	10.00	32.26	9.39	30.00	8.77	28.81	8.48	27.74	8.16	25.36	7.58
11	9.8	34.64	9.51	32.26	8.96	30.00	8.43	28.81	8.16	27.74	7.89	25.36	7.38	
13	11.8	34.64	9.07	32.26	8.59	30.00	8.13	28.81	7.89	27.74	7.66	25.36	7.20	

	15	13.7	34.64	8.76	32.26	8.33	30.00	7.91	28.81	7.71	27.74	7.50	25.36	7.08
--	----	------	-------	------	-------	------	-------	------	-------	------	-------	------	-------	------

Abbreviations:

CR: Combination ratio

TC: Total capacity (kW)

PI: Power input (compressor + outdoor fan motor) (kW)

Notes:

Shaded cells indicate rating condition.

Table 2-8.16: 12HP heating capacity (continued)

CR	Outdoor air temp.		Indoor air temp. °C DB											
			16		18		20		21		22		24	
	°C DB	°C WB	TC kW	PI kW	TC kW	PI kW	TC kW	PI kW	TC kW	PI kW	TC kW	PI kW	TC kW	PI kW
70%	-25	-25.4	30.00	14.79	28.21	13.68	26.31	13.45	25.24	13.20	24.29	13.04	22.26	12.55
	-19.8	-20	30.00	14.09	28.21	12.96	26.31	12.70	25.24	12.45	24.29	12.29	22.26	11.80
	-18.8	-19	30.24	13.93	28.21	12.82	26.31	12.56	25.24	12.32	24.29	12.16	22.26	11.67
	-16.7	-17	30.24	13.65	28.21	12.57	26.31	12.34	25.24	12.10	24.29	11.94	22.26	11.45
	-13.7	-15	30.24	13.38	28.21	12.32	26.31	12.11	25.24	11.86	24.29	11.70	22.26	11.21
	-11.8	-13	30.24	13.11	28.21	12.08	26.31	11.91	25.24	11.66	24.29	11.50	22.26	11.01
	-9.8	-11	30.24	12.86	28.21	11.85	26.31	11.69	25.24	11.44	24.29	11.28	22.26	10.79
	-9.5	-10	30.24	12.74	28.21	11.75	26.31	11.39	25.24	11.15	24.29	10.99	22.26	10.50
	-8.5	-9.1	30.24	12.62	28.21	11.65	26.31	11.01	25.24	10.77	24.29	10.61	22.26	10.12
	-7	-7.6	30.24	12.45	28.21	11.48	26.31	10.54	25.24	10.29	24.29	10.13	22.26	9.64
	-5	-5.6	30.24	12.07	28.21	11.14	26.31	10.25	25.24	10.00	24.29	9.84	22.26	9.35
	-3	-3.7	30.24	11.42	28.21	10.80	26.31	9.95	25.24	9.70	24.29	9.54	22.26	9.05
	0	-0.7	30.24	10.81	28.21	10.33	26.31	9.53	25.24	9.28	24.29	9.12	22.26	8.63
	3	2.2	30.24	10.20	28.21	9.77	26.31	8.94	25.24	8.70	24.29	8.54	22.26	8.05
	5	4.1	30.24	9.74	28.21	9.15	26.31	8.61	25.24	8.36	24.29	8.20	22.26	7.71
7	6	30.24	9.36	28.21	8.75	26.31	8.16	25.24	7.94	24.29	7.78	22.26	7.29	
9	7.9	30.24	8.95	28.21	8.41	26.31	7.89	25.24	7.65	24.29	7.48	22.26	7.00	
11	9.8	30.24	8.60	28.21	8.13	26.31	7.58	25.24	7.33	24.29	7.17	22.26	6.68	
13	11.8	30.24	8.28	28.21	7.79	26.31	7.21	25.24	6.97	24.29	6.80	22.26	6.31	
15	13.7	30.24	7.98	28.21	7.45	26.31	6.93	25.24	6.68	24.29	6.52	22.26	6.03	
60%	-25	-25.4	25.95	13.79	24.29	13.04	22.50	12.43	21.67	12.15	20.71	11.64	19.05	11.03
	-19.8	-20	25.95	13.06	24.29	12.44	22.50	11.96	21.67	11.62	20.71	11.09	19.05	10.46
	-18.8	-19	25.95	12.72	24.29	12.01	22.50	11.54	21.67	11.23	20.71	10.66	19.05	10.09
	-16.7	-17	25.95	12.32	24.29	11.64	22.50	11.18	21.67	10.80	20.71	10.26	19.05	9.69
	-13.7	-15	25.95	11.90	24.29	11.29	22.50	10.83	21.67	10.39	20.71	9.86	19.05	9.28
	-11.8	-13	25.95	11.48	24.29	10.87	22.50	10.42	21.67	10.04	20.71	9.44	19.05	8.87
	-9.8	-11	25.95	11.11	24.29	10.47	22.50	9.92	21.67	9.58	20.71	9.04	19.05	8.54
	-9.5	-10	25.95	10.71	24.29	10.05	22.50	9.51	21.67	9.17	20.71	8.65	19.05	8.08
	-8.5	-9.1	25.95	10.26	24.29	9.69	22.50	9.11	21.67	8.78	20.71	8.24	19.05	7.62
	-7	-7.6	25.95	9.88	24.29	9.27	22.50	8.80	21.67	8.48	20.71	7.92	19.05	7.28
	-5	-5.6	25.95	9.52	24.29	8.93	22.50	8.36	21.67	8.13	20.71	7.61	19.05	6.94
	-3	-3.7	25.95	9.18	24.29	8.58	22.50	7.99	21.67	7.80	20.71	7.27	19.05	6.69
	0	-0.7	25.95	8.82	24.29	8.24	22.50	7.63	21.67	7.43	20.71	6.91	19.05	6.57
	3	2.2	25.95	8.41	24.29	7.84	22.50	7.34	21.67	7.12	20.71	6.55	19.05	6.33
	5	4.1	25.95	7.98	24.29	7.51	22.50	7.07	21.67	6.81	20.71	6.41	19.05	6.19
7	6	25.95	7.62	24.29	7.19	22.50	6.74	21.67	6.53	20.71	6.37	19.05	6.08	
9	7.9	25.95	7.49	24.29	7.03	22.50	6.63	21.67	6.38	20.71	6.10	19.05	5.81	
11	9.8	25.95	7.37	24.29	6.92	22.50	6.46	21.67	6.22	20.71	5.98	19.05	5.70	
13	11.8	25.95	7.15	24.29	6.69	22.50	6.26	21.67	6.09	20.71	5.85	19.05	5.57	
15	13.7	25.95	7.06	24.29	6.56	22.50	6.07	21.67	5.94	20.71	5.70	19.05	5.41	
50%	-25	-25.4	21.67	11.42	20.24	10.79	18.81	10.29	17.98	10.06	17.26	9.80	15.83	9.14
	-19.8	-20	21.67	10.81	20.24	10.30	18.81	9.90	17.98	9.62	17.26	9.35	15.83	8.66
	-18.8	-19	21.67	10.53	20.24	9.94	18.81	9.55	17.98	9.30	17.26	8.99	15.83	8.35
	-16.7	-17	21.67	10.20	20.24	9.63	18.81	9.26	17.98	8.94	17.26	8.66	15.83	8.02
	-13.7	-15	21.67	9.85	20.24	9.35	18.81	8.97	17.98	8.61	17.26	8.33	15.83	7.69
	-11.8	-13	21.67	9.50	20.24	9.00	18.81	8.62	17.98	8.31	17.26	7.98	15.83	7.34
	-9.8	-11	21.67	9.19	20.24	8.67	18.81	8.21	17.98	7.93	17.26	7.65	15.83	7.07
	-9.5	-10	21.67	8.87	20.24	8.32	18.81	7.87	17.98	7.59	17.26	7.33	15.83	6.69
	-8.5	-9.1	21.67	8.50	20.24	8.02	18.81	7.55	17.98	7.27	17.26	6.99	15.83	6.31
	-7	-7.6	21.67	8.18	20.24	7.68	18.81	7.28	17.98	7.02	17.26	6.73	15.83	6.03
	-5	-5.6	21.67	7.88	20.24	7.39	18.81	6.92	17.98	6.73	17.26	6.46	15.83	5.74
	-3	-3.7	21.67	7.60	20.24	7.10	18.81	6.61	17.98	6.46	17.26	6.19	15.83	5.54
	0	-0.7	21.67	7.30	20.24	6.82	18.81	6.32	17.98	6.15	17.26	5.89	15.83	5.44
	3	2.2	21.67	6.96	20.24	6.49	18.81	6.08	17.98	5.90	17.26	5.59	15.83	5.41
	5	4.1	21.67	6.61	20.24	6.22	18.81	5.85	17.98	5.63	17.26	5.47	15.83	5.35
7	6	21.67	6.31	20.24	5.95	18.81	5.58	17.98	5.41	17.26	5.39	15.83	5.20	
9	7.9	21.67	6.20	20.24	5.82	18.81	5.49	17.98	5.28	17.26	5.16	15.83	5.03	
11	9.8	21.67	6.11	20.24	5.73	18.81	5.35	17.98	5.15	17.26	5.07	15.83	4.94	

MDV6 VRF 50Hz



	13	11.8	21.67	5.92	20.24	5.54	18.81	5.18	17.98	5.04	17.26	4.96	15.83	4.84
	15	13.7	21.67	5.84	20.24	5.43	18.81	5.03	17.98	4.92	17.26	4.82	15.83	4.70

Abbreviations:

CR: Combination ratio

TC: Total capacity (kW)

PI: Power input (compressor + outdoor fan motor) (kW)

Notes: Shaded cells indicate rating condition.

Table 2-8.17: 14HP heating capacity

CR	Outdoor air temp.		Indoor air temp. °C DB											
			16		18		20		21		22		24	
	°C DB	°C WB	TC kW	PI kW	TC kW	PI kW	TC kW	PI kW	TC kW	PI kW	TC kW	PI kW	TC kW	PI kW
130%	-25	-25.4	35.10	11.46	34.96	11.66	34.23	12.13	34.12	12.47	34.09	12.81	33.89	13.01
	-19.8	-20	36.90	11.76	36.76	12.02	36.61	12.62	36.47	12.97	36.47	13.31	36.33	13.48
	-18.8	-19	37.18	11.98	37.04	12.18	36.90	12.74	36.90	13.08	36.76	13.43	36.61	13.55
	-16.7	-17	37.75	12.11	37.61	12.39	37.47	12.88	37.47	13.22	37.33	13.56	37.18	13.78
	-13.7	-15	38.32	12.25	38.18	12.58	38.04	13.10	38.04	13.45	37.90	13.79	37.75	13.97
	-11.8	-13	38.89	12.46	38.75	12.78	38.61	13.35	38.61	13.69	38.47	14.03	38.47	14.18
	-9.8	-11	39.46	12.65	39.32	13.01	39.18	13.49	39.18	13.83	39.18	14.17	39.03	14.20
	-9.5	-10	39.75	12.84	39.60	13.14	39.60	13.70	39.46	14.04	39.46	14.38	39.32	14.42
	-8.5	-9.1	40.03	13.01	39.89	13.33	39.75	13.85	39.75	14.19	39.75	14.53	39.60	14.58
	-7	-7.6	40.46	13.03	40.32	13.51	40.32	13.97	40.17	14.30	40.17	14.74	40.03	14.77
	-5	-5.6	43.59	13.60	43.45	13.89	43.31	14.41	43.31	14.85	43.17	14.83	43.02	14.95
	-3	-3.7	44.16	13.93	44.02	14.12	43.88	14.65	43.88	15.09	43.74	15.03	43.59	15.14
	0	-0.7	45.02	14.34	44.88	14.26	44.73	14.83	44.73	15.24	44.59	15.25	44.59	15.26
	3	2.2	49.73	15.16	49.15	15.18	49.01	15.60	48.86	15.89	48.86	16.06	48.72	16.19
	5	4.1	61.83	18.32	59.35	18.10	58.41	18.03	56.13	17.45	53.85	17.26	49.43	16.51
	7	6	62.83	18.46	60.49	17.61	58.41	17.15	56.13	16.70	53.85	16.54	49.43	15.94
9	7.9	62.83	17.56	60.49	16.77	58.41	16.62	56.13	16.40	53.85	16.12	49.43	15.57	
11	9.8	62.83	16.71	60.49	16.08	58.41	16.05	56.13	15.85	53.85	15.65	49.43	14.98	
13	11.8	62.83	15.90	60.49	15.61	58.41	15.61	56.13	15.58	53.85	15.31	49.43	14.71	
15	13.7	62.83	15.40	60.49	15.26	58.41	15.17	56.13	14.96	53.85	14.87	49.43	14.16	
120%	-25	-25.4	34.76	12.49	34.62	12.95	34.59	13.40	34.48	13.72	34.32	14.05	34.22	14.25
	-19.8	-20	36.86	12.83	36.71	13.26	36.57	13.64	36.57	13.97	36.43	14.29	36.29	14.54
	-18.8	-19	37.14	13.01	37.00	13.28	36.86	13.88	36.86	14.20	36.71	14.52	36.57	14.70
	-16.7	-17	37.71	13.20	37.57	13.47	37.43	14.06	37.43	14.39	37.29	14.71	37.29	14.75
	-13.7	-15	38.29	13.37	38.14	13.74	38.00	14.13	38.00	14.45	38.00	14.78	37.86	14.90
	-11.8	-13	38.86	13.57	38.71	13.89	38.63	14.31	38.57	14.64	38.57	14.96	38.43	15.07
	-9.8	-11	39.43	13.65	39.29	13.99	39.29	14.48	39.14	14.80	39.14	15.12	39.00	15.35
	-9.5	-10	39.71	13.80	39.57	14.09	39.57	14.58	39.43	14.90	39.43	15.22	39.29	15.54
	-8.5	-9.1	40.00	13.94	39.86	14.27	39.86	14.74	39.71	15.06	39.71	15.39	39.57	15.56
	-7	-7.6	40.43	14.19	40.29	14.53	40.29	14.90	40.14	15.23	40.14	15.55	40.00	15.73
	-5	-5.6	43.57	14.30	43.43	14.64	43.29	15.06	43.29	15.38	43.29	15.71	43.14	16.00
	-3	-3.7	44.14	14.55	44.00	14.88	43.86	15.25	43.86	15.58	43.71	15.90	43.71	16.08
	0	-0.7	45.00	14.74	44.86	15.09	44.71	15.38	44.71	15.71	44.71	16.03	44.57	16.19
	3	2.2	49.14	15.63	49.14	16.04	49.00	16.17	48.86	16.49	48.86	16.82	45.71	16.03
	5	4.1	61.86	17.52	58.14	17.34	54.00	17.06	51.86	16.71	49.86	16.53	45.71	15.55
	7	6	62.29	17.40	58.14	16.61	54.00	16.19	51.86	15.91	49.86	15.81	45.71	15.17
9	7.9	62.29	16.64	58.14	15.87	54.00	15.70	51.86	15.39	49.86	15.36	45.71	14.70	
11	9.8	62.29	16.10	58.14	15.54	54.00	15.16	51.86	14.93	49.86	14.81	45.71	14.16	
13	11.8	62.29	15.71	58.14	15.14	54.00	14.74	51.86	14.70	49.86	14.53	45.71	13.88	
15	13.7	62.29	15.36	58.14	14.69	54.00	14.33	51.86	14.16	49.86	14.04	45.71	13.37	
110%	-25	-25.4	35.19	12.86	35.03	13.16	34.86	13.46	34.91	13.25	34.78	13.51	34.76	13.86
	-19.8	-20	36.71	13.04	36.57	13.34	36.43	13.64	36.43	13.43	36.29	13.69	36.29	14.03
	-18.8	-19	37.00	13.24	36.86	13.54	36.71	13.84	36.71	13.45	36.57	13.84	36.57	14.08
	-16.7	-17	37.57	13.43	37.43	13.73	37.29	14.03	37.29	13.71	37.29	14.00	37.14	14.26
	-13.7	-15	38.14	13.55	38.00	13.85	37.86	14.15	37.86	13.80	37.86	14.06	37.71	14.41
	-11.8	-13	38.71	13.75	38.57	14.05	38.57	14.35	38.43	13.94	38.43	14.23	38.29	14.58
	-9.8	-11	39.29	13.75	39.14	14.05	39.14	14.35	39.00	14.19	39.00	14.40	38.86	14.77
	-9.5	-10	39.57	13.90	39.57	14.20	39.43	14.50	39.29	14.24	39.29	14.57	39.14	14.92
	-8.5	-9.1	39.86	14.05	39.71	14.35	39.71	14.65	39.57	14.38	39.57	14.72	39.43	15.08
	-7	-7.6	40.29	14.21	40.14	14.50	40.14	14.80	40.00	14.59	40.00	14.89	39.86	15.13
	-5	-5.6	43.43	14.39	43.29	14.69	43.14	14.99	43.14	14.73	43.14	14.97	41.86	14.96
	-3	-3.7	44.00	14.50	43.86	14.80	43.71	15.10	43.71	14.86	43.71	15.17	41.86	14.71
	0	-0.7	44.86	14.85	44.71	15.15	44.71	15.45	44.57	14.98	44.57	15.31	41.86	14.50
	3	2.2	49.00	15.51	49.00	15.81	48.86	16.11	47.57	15.58	45.71	15.42	41.86	14.38
	5	4.1	57.14	16.93	53.29	16.88	49.57	15.74	47.57	15.30	45.71	15.03	41.86	14.32
	7	6	57.14	16.30	53.29	15.90	49.57	14.95	47.57	14.55	45.71	14.33	41.86	13.96
9	7.9	57.14	15.56	53.29	15.04	49.57	14.41	47.57	14.18	45.71	14.03	41.86	13.72	
11	9.8	57.14	15.00	53.29	14.49	49.57	14.00	47.57	13.67	45.71	13.57	41.86	13.27	

	13	11.8	57.14	14.56	53.29	14.04	49.57	13.55	47.57	13.27	45.71	13.11	41.86	12.81
	15	13.7	57.14	14.15	53.29	13.58	49.57	13.10	47.57	12.82	45.71	12.67	41.86	12.36

Abbreviations:

CR: Combination ratio

TC: Total capacity (kW)

PI: Power input (compressor + outdoor fan motor) (kW)

Notes:

Shaded cells indicate rating condition.

Table 2-8.17: 14HP heating capacity (continued)

CR	Outdoor air temp.		Indoor air temp. °C DB											
			16		18		20		21		22		24	
	°C DB	°C WB	TC kW	PI kW	TC kW	PI kW	TC kW	PI kW	TC kW	PI kW	TC kW	PI kW	TC kW	PI kW
100%	-25	-25.4	35.22	16.06	35.08	16.22	34.94	16.31	34.94	16.49	34.94	16.59	34.79	16.81
	-19.8	-20	36.86	16.06	36.71	16.24	36.57	16.41	36.57	16.51	36.57	16.61	36.43	16.69
	-18.8	-19	37.43	16.10	37.29	16.28	37.14	16.45	37.14	16.53	37.14	16.63	37.00	16.56
	-16.7	-17	38.00	16.12	37.86	16.30	37.86	16.47	37.71	16.57	37.71	16.67	37.57	16.47
	-13.7	-15	38.57	16.16	38.43	16.32	38.43	16.51	38.29	16.59	38.29	16.69	38.14	16.28
	-11.8	-13	39.14	16.18	39.00	16.36	39.00	16.53	38.86	16.63	38.86	16.71	38.14	16.10
	-9.8	-11	39.43	16.20	39.43	16.38	39.29	16.55	39.29	16.63	39.14	16.73	38.14	16.08
	-9.5	-10	39.71	16.22	39.57	16.38	39.57	16.59	39.43	16.65	39.43	16.75	38.14	15.94
	-8.5	-9.1	40.14	16.24	40.14	16.40	40.00	16.65	39.86	16.67	39.86	16.77	38.14	15.70
	-7	-7.6	43.29	16.26	43.14	16.40	43.14	16.98	43.00	17.28	41.57	16.43	38.14	15.64
	-5	-5.6	43.86	16.28	43.71	16.41	43.71	16.59	43.29	16.79	41.57	15.94	38.14	15.20
	-3	-3.7	44.71	16.30	44.57	16.42	44.57	16.04	43.29	15.82	41.57	15.44	38.14	14.70
	0	-0.7	45.86	16.32	48.43	16.43	45.00	15.60	43.29	15.10	41.57	14.68	38.14	14.06
	3	2.2	48.86	15.99	48.43	16.02	45.00	15.15	43.29	14.37	41.57	13.81	38.14	13.37
	5	4.1	51.86	15.74	48.43	15.24	45.00	14.43	43.29	13.72	41.57	13.25	38.14	12.77
7	6	51.86	15.54	48.43	14.46	45.00	13.52	43.29	12.99	41.57	12.71	38.14	12.21	
9	7.9	51.86	14.65	48.43	13.69	45.00	13.14	43.29	12.67	41.57	12.33	38.14	11.82	
11	9.8	51.86	13.71	48.43	12.85	45.00	12.70	43.29	12.16	41.57	11.88	38.14	11.32	
13	11.8	51.86	12.85	48.43	12.53	45.00	12.21	43.29	11.72	41.57	11.46	38.14	10.94	
15	13.7	51.86	12.22	48.43	12.00	45.00	11.76	43.29	11.31	41.57	11.05	38.14	10.51	
90%	-25	-25.4	34.95	16.05	34.76	16.20	34.65	16.38	34.62	16.59	34.62	16.65	34.29	15.61
	-19.8	-20	36.43	16.32	36.29	16.47	36.14	16.65	36.14	16.75	36.14	16.85	34.29	15.28
	-18.8	-19	36.71	16.34	36.57	16.49	36.43	16.67	36.43	16.77	36.43	16.79	34.29	15.12
	-16.7	-17	37.29	16.36	37.14	16.51	37.14	16.69	37.00	16.79	37.00	16.45	34.29	14.81
	-13.7	-15	37.86	16.38	37.71	16.55	37.71	16.73	37.57	16.81	37.43	16.12	34.29	14.51
	-11.8	-13	38.43	16.41	38.29	16.57	38.29	16.75	38.14	16.59	37.43	15.79	34.29	14.24
	-9.8	-11	39.00	16.43	39.00	16.61	38.86	16.77	38.86	16.26	37.43	15.49	34.29	13.97
	-9.5	-10	39.29	16.45	39.29	16.61	39.14	16.79	39.00	16.10	37.43	15.34	34.29	13.83
	-8.5	-9.1	39.57	16.47	39.43	16.63	39.43	16.75	39.00	15.96	37.43	15.20	34.29	13.71
	-7	-7.6	40.00	16.49	40.00	16.41	39.86	16.51	39.00	15.75	37.43	14.99	34.29	13.52
	-5	-5.6	43.14	16.52	43.00	15.70	40.57	15.82	39.00	15.22	37.43	14.51	34.29	13.12
	-3	-3.7	43.71	16.54	43.57	15.01	40.57	15.04	39.00	14.66	37.43	14.05	34.29	12.79
	0	-0.7	44.57	16.57	43.57	14.25	40.57	14.40	39.00	13.96	37.43	13.36	34.29	12.46
	3	2.2	46.71	16.59	43.57	13.50	40.57	13.58	39.00	13.43	37.43	12.76	34.29	12.04
	5	4.1	46.71	16.18	43.57	12.84	40.57	12.97	39.00	12.74	37.43	12.17	34.29	11.56
7	6	46.71	14.06	43.57	12.60	40.57	12.13	39.00	11.66	37.43	11.20	34.29	10.28	
9	7.9	46.71	13.20	43.57	12.36	40.57	11.52	39.00	11.11	37.43	10.70	34.29	9.89	
11	9.8	46.71	12.44	43.57	11.69	40.57	10.97	39.00	10.60	37.43	10.24	34.29	9.54	
13	11.8	46.71	11.75	43.57	11.11	40.57	10.48	39.00	10.17	37.43	9.85	34.29	9.23	
15	13.7	46.71	11.26	43.57	10.70	40.57	10.13	39.00	9.85	37.43	9.58	34.29	9.01	
80%	-25	-25.4	34.90	17.02	34.76	17.23	34.92	16.71	34.57	15.91	33.29	15.23	30.43	13.81
	-19.8	-20	36.29	16.38	36.14	16.56	36.00	16.00	34.57	15.26	33.29	14.55	30.43	13.13
	-18.8	-19	36.57	16.40	36.43	16.56	36.00	15.84	34.57	15.11	33.29	14.39	30.43	13.00
	-16.7	-17	37.14	16.42	37.00	16.60	36.00	15.51	34.57	14.80	33.29	14.10	30.43	12.73
	-13.7	-15	37.71	16.46	37.57	16.62	36.00	15.20	34.57	14.51	33.29	13.83	30.43	12.50
	-11.8	-13	38.29	16.48	38.14	16.31	36.00	14.89	34.57	14.22	33.29	13.56	30.43	12.26
	-9.8	-11	38.86	16.50	38.71	15.98	36.00	14.62	34.57	13.95	33.29	13.31	30.43	12.03
	-9.5	-10	39.14	16.52	38.71	15.82	36.00	14.47	34.57	13.81	33.29	13.17	30.43	11.92
	-8.5	-9.1	39.43	16.54	38.71	15.69	36.00	14.35	34.57	13.69	33.29	13.06	30.43	11.82
	-7	-7.6	39.86	16.56	38.71	15.46	36.00	14.16	34.57	13.52	33.29	12.88	30.43	11.66
	-5	-5.6	41.57	16.23	38.71	14.95	36.00	13.71	34.57	13.10	33.29	12.51	30.43	11.33
	-3	-3.7	41.57	16.79	38.71	14.41	36.00	13.13	34.57	12.60	33.29	12.06	30.43	11.01
	0	-0.7	41.57	16.58	38.71	13.74	36.00	12.68	34.57	12.23	33.29	11.70	30.43	10.76
	3	2.2	41.57	15.32	38.71	12.97	36.00	11.96	34.57	11.80	33.29	11.26	30.43	10.34
	5	4.1	41.57	14.00	38.71	12.25	36.00	11.41	34.57	11.32	33.29	10.73	30.43	10.12
7	6	41.57	12.28	38.71	11.47	36.00	10.66	34.57	10.25	33.29	9.86	30.43	9.09	
9	7.9	41.57	11.64	38.71	10.93	36.00	10.21	34.57	9.86	33.29	9.50	30.43	8.82	

MDV6 VRF 50Hz



	11	9.8	41.57	11.06	38.71	10.43	36.00	9.81	34.57	9.50	33.29	9.19	30.43	8.59
	13	11.8	41.57	10.56	38.71	10.00	36.00	9.46	34.57	9.19	33.29	8.92	30.43	8.38
	15	13.7	41.57	10.19	38.71	9.69	36.00	9.21	34.57	8.98	33.29	8.72	30.43	8.24

Abbreviations:

CR: Combination ratio

TC: Total capacity (kW)

PI: Power input (compressor + outdoor fan motor) (kW)

Notes:

Shaded cells indicate rating condition.

Table 2-8.17: 14HP heating capacity (continued)

CR	Outdoor air temp.		Indoor air temp. °C DB											
			16		18		20		21		22		24	
	°C DB	°C WB	TC	PI	TC	PI	TC	PI	TC	PI	TC	PI	TC	PI
70%	-25	-25.4	36.00	17.22	33.86	15.92	31.57	15.65	30.29	15.37	29.14	15.18	26.71	14.61
	-19.8	-20	36.00	16.40	33.86	15.08	31.57	14.78	30.29	14.49	29.14	14.30	26.71	13.73
	-18.8	-19	36.29	16.22	33.86	14.93	31.57	14.62	30.29	14.34	29.14	14.15	26.71	13.58
	-16.7	-17	36.29	15.89	33.86	14.63	31.57	14.37	30.29	14.08	29.14	13.89	26.71	13.32
	-13.7	-15	36.29	15.57	33.86	14.34	31.57	14.09	30.29	13.81	29.14	13.62	26.71	13.05
	-11.8	-13	36.29	15.26	33.86	14.06	31.57	13.86	30.29	13.57	29.14	13.38	26.71	12.81
	-9.8	-11	36.29	14.97	33.86	13.79	31.57	13.60	30.29	13.32	29.14	13.13	26.71	12.56
	-9.5	-10	36.29	14.83	33.86	13.67	31.57	13.26	30.29	12.98	29.14	12.79	26.71	12.22
	-8.5	-9.1	36.29	14.69	33.86	13.56	31.57	12.82	30.29	12.53	29.14	12.34	26.71	11.77
	-7	-7.6	36.29	14.50	33.86	13.36	31.57	12.26	30.29	11.98	29.14	11.79	26.71	11.22
	-5	-5.6	36.29	14.04	33.86	12.97	31.57	11.93	30.29	11.64	29.14	11.45	26.71	10.88
	-3	-3.7	36.29	13.29	33.86	12.58	31.57	11.58	30.29	11.30	29.14	11.11	26.71	10.54
	0	-0.7	36.29	12.59	33.86	12.03	31.57	11.09	30.29	10.80	29.14	10.61	26.71	10.04
	3	2.2	36.29	11.88	33.86	11.37	31.57	10.41	30.29	10.13	29.14	9.94	26.71	9.37
	5	4.1	36.29	11.33	33.86	10.64	31.57	10.02	30.29	9.73	29.14	9.54	26.71	8.97
7	6	36.29	10.89	33.86	10.19	31.57	9.50	30.29	9.24	29.14	9.05	26.71	8.48	
9	7.9	36.29	10.42	33.86	9.79	31.57	9.19	30.29	8.90	29.14	8.71	26.71	8.14	
11	9.8	36.29	10.01	33.86	9.46	31.57	8.82	30.29	8.53	29.14	8.34	26.71	7.77	
13	11.8	36.29	9.64	33.86	9.07	31.57	8.39	30.29	8.11	29.14	7.92	26.71	7.35	
15	13.7	36.29	9.29	33.86	8.67	31.57	8.07	30.29	7.78	29.14	7.59	26.71	7.02	
60%	-25	-25.4	31.14	16.05	29.14	15.17	27.00	14.47	26.00	14.14	24.86	13.55	22.86	12.84
	-19.8	-20	31.14	15.20	29.14	14.47	27.00	13.92	26.00	13.52	24.86	12.91	22.86	12.18
	-18.8	-19	31.14	14.81	29.14	13.98	27.00	13.43	26.00	13.07	24.86	12.41	22.86	11.74
	-16.7	-17	31.14	14.34	29.14	13.54	27.00	13.02	26.00	12.57	24.86	11.94	22.86	11.27
	-13.7	-15	31.14	13.85	29.14	13.14	27.00	12.61	26.00	12.10	24.86	11.48	22.86	10.81
	-11.8	-13	31.14	13.36	29.14	12.65	27.00	12.12	26.00	11.68	24.86	10.99	22.86	10.32
	-9.8	-11	31.14	12.93	29.14	12.18	27.00	11.54	26.00	11.15	24.86	10.52	22.86	9.94
	-9.5	-10	31.14	12.47	29.14	11.69	27.00	11.07	26.00	10.67	24.86	10.06	22.86	9.40
	-8.5	-9.1	31.14	11.95	29.14	11.27	27.00	10.61	26.00	10.21	24.86	9.59	22.86	8.87
	-7	-7.6	31.14	11.50	29.14	10.79	27.00	10.24	26.00	9.87	24.86	9.22	22.86	8.48
	-5	-5.6	31.14	11.08	29.14	10.40	27.00	9.73	26.00	9.46	24.86	8.85	22.86	8.08
	-3	-3.7	31.14	10.69	29.14	9.98	27.00	9.30	26.00	9.08	24.86	8.46	22.86	7.79
	0	-0.7	31.14	10.26	29.14	9.59	27.00	8.88	26.00	8.64	24.86	8.04	22.86	7.64
	3	2.2	31.14	9.79	29.14	9.13	27.00	8.54	26.00	8.29	24.86	7.63	22.86	7.37
	5	4.1	31.14	9.29	29.14	8.74	27.00	8.23	26.00	7.92	24.86	7.46	22.86	7.21
7	6	31.14	8.87	29.14	8.37	27.00	7.84	26.00	7.60	24.86	7.42	22.86	7.07	
9	7.9	31.14	8.71	29.14	8.18	27.00	7.72	26.00	7.42	24.86	7.10	22.86	6.76	
11	9.8	31.14	8.58	29.14	8.06	27.00	7.52	26.00	7.24	24.86	6.96	22.86	6.63	
13	11.8	31.14	8.32	29.14	7.79	27.00	7.28	26.00	7.09	24.86	6.81	22.86	6.48	
15	13.7	31.14	8.22	29.14	7.63	27.00	7.07	26.00	6.92	24.86	6.64	22.86	6.30	
50%	-25	-25.4	26.00	13.29	24.29	12.56	22.57	11.98	21.57	11.71	20.71	11.41	19.00	10.63
	-19.8	-20	26.00	12.58	24.29	11.98	22.57	11.53	21.57	11.20	20.71	10.89	19.00	10.08
	-18.8	-19	26.00	12.26	24.29	11.57	22.57	11.12	21.57	10.82	20.71	10.47	19.00	9.72
	-16.7	-17	26.00	11.87	24.29	11.21	22.57	10.78	21.57	10.40	20.71	10.08	19.00	9.33
	-13.7	-15	26.00	11.46	24.29	10.88	22.57	10.44	21.57	10.02	20.71	9.70	19.00	8.95
	-11.8	-13	26.00	11.06	24.29	10.48	22.57	10.04	21.57	9.67	20.71	9.29	19.00	8.55
	-9.8	-11	26.00	10.70	24.29	10.09	22.57	9.56	21.57	9.23	20.71	8.91	19.00	8.23
	-9.5	-10	26.00	10.32	24.29	9.68	22.57	9.17	21.57	8.84	20.71	8.53	19.00	7.78
	-8.5	-9.1	26.00	9.89	24.29	9.33	22.57	8.78	21.57	8.46	20.71	8.14	19.00	7.34
	-7	-7.6	26.00	9.52	24.29	8.94	22.57	8.48	21.57	8.17	20.71	7.83	19.00	7.02
	-5	-5.6	26.00	9.17	24.29	8.61	22.57	8.06	21.57	7.83	20.71	7.52	19.00	6.69
	-3	-3.7	26.00	8.85	24.29	8.26	22.57	7.70	21.57	7.52	20.71	7.20	19.00	6.45
	0	-0.7	26.00	8.49	24.29	7.94	22.57	7.35	21.57	7.16	20.71	6.85	19.00	6.33
	3	2.2	26.00	8.11	24.29	7.56	22.57	7.07	21.57	6.86	20.71	6.51	19.00	6.29
	5	4.1	26.00	7.69	24.29	7.23	22.57	6.81	21.57	6.56	20.71	6.37	19.00	6.23
7	6	26.00	7.34	24.29	6.93	22.57	6.49	21.57	6.29	20.71	6.27	19.00	6.05	
9	7.9	26.00	7.21	24.29	6.77	22.57	6.39	21.57	6.14	20.71	6.01	19.00	5.86	

	11	9.8	26.00	7.11	24.29	6.67	22.57	6.22	21.57	6.00	20.71	5.90	19.00	5.75
	13	11.8	26.00	6.89	24.29	6.45	22.57	6.03	21.57	5.87	20.71	5.77	19.00	5.63
	15	13.7	26.00	6.80	24.29	6.32	22.57	5.85	21.57	5.73	20.71	5.61	19.00	5.48

Abbreviations:

CR: Combination ratio

TC: Total capacity (kW)

PI: Power input (compressor + outdoor fan motor) (kW)

Notes: Shaded cells indicate rating condition.

Table 2-8.18: 16HP heating capacity

CR	Outdoor air temp.		Indoor air temp. °C DB											
			16		18		20		21		22		24	
	°C DB	°C WB	TC kW	PI kW	TC kW	PI kW	TC kW	PI kW	TC kW	PI kW	TC kW	PI kW	TC kW	PI kW
130%	-25	-25.4	39.00	13.93	38.85	14.17	38.04	14.73	37.91	15.15	37.88	15.56	37.66	15.81
	-19.8	-20	41.00	14.29	40.84	14.60	40.68	15.33	40.52	15.75	40.52	16.17	40.36	16.37
	-18.8	-19	41.31	14.55	41.16	14.79	41.00	15.48	41.00	15.89	40.84	16.31	40.68	16.46
	-16.7	-17	41.95	14.71	41.79	15.05	41.63	15.64	41.63	16.06	41.47	16.48	41.31	16.75
	-13.7	-15	42.58	14.89	42.42	15.28	42.26	15.92	42.26	16.34	42.11	16.75	41.95	16.98
	-11.8	-13	43.21	15.14	43.06	15.53	42.90	16.22	42.90	16.63	42.74	17.05	42.74	17.23
	-9.8	-11	43.85	15.37	43.69	15.81	43.53	16.39	43.53	16.80	43.53	17.22	43.37	17.25
	-9.5	-10	44.16	15.60	44.01	15.96	44.01	16.64	43.85	17.05	43.85	17.47	43.69	17.52
	-8.5	-9.1	44.48	15.81	44.32	16.19	44.16	16.82	44.16	17.24	44.16	17.65	44.01	17.72
	-7	-7.6	44.96	15.83	44.80	16.42	44.80	16.98	44.64	17.37	44.64	17.90	44.48	17.95
	-5	-5.6	48.44	16.53	48.28	16.88	48.12	17.51	48.12	18.04	47.96	18.02	47.80	18.16
	-3	-3.7	49.07	16.93	48.91	17.15	48.75	17.80	48.75	18.33	48.60	18.25	48.44	18.39
	0	-0.7	50.02	17.42	49.86	17.32	49.70	18.02	49.70	18.52	49.55	18.53	49.55	18.54
	3	2.2	55.26	18.42	54.61	18.44	54.45	18.96	54.29	19.31	54.29	19.51	54.14	19.67
	5	4.1	68.70	22.25	65.94	21.99	64.90	21.90	62.37	21.20	59.83	20.97	54.93	20.06
7	6	69.81	22.43	67.21	21.40	64.90	20.83	62.37	20.29	59.83	20.10	54.93	19.37	
9	7.9	69.81	21.33	67.21	20.38	64.90	20.20	62.37	19.92	59.83	19.59	54.93	18.92	
11	9.8	69.81	20.30	67.21	19.54	64.90	19.50	62.37	19.25	59.83	19.01	54.93	18.19	
13	11.8	69.81	19.31	67.21	18.96	64.90	18.96	62.37	18.93	59.83	18.59	54.93	17.87	
15	13.7	69.81	18.71	67.21	18.54	64.90	18.43	62.37	18.18	59.83	18.06	54.93	17.21	
120%	-25	-25.4	38.62	15.17	38.46	15.73	38.43	16.28	38.31	16.67	38.13	17.07	38.02	17.31
	-19.8	-20	40.95	15.59	40.79	16.11	40.63	16.58	40.63	16.97	40.48	17.36	40.32	17.66
	-18.8	-19	41.27	15.81	41.11	16.13	40.95	16.86	40.95	17.25	40.79	17.64	40.63	17.86
	-16.7	-17	41.90	16.04	41.75	16.37	41.59	17.09	41.59	17.48	41.43	17.87	41.43	17.92
	-13.7	-15	42.54	16.25	42.38	16.70	42.22	17.17	42.22	17.56	42.22	17.95	42.06	18.10
	-11.8	-13	43.17	16.49	43.02	16.87	42.93	17.39	42.86	17.78	42.86	18.18	42.70	18.30
	-9.8	-11	43.81	16.58	43.65	16.99	43.65	17.59	43.49	17.98	43.49	18.37	43.33	18.64
	-9.5	-10	44.13	16.77	43.97	17.12	43.97	17.71	43.81	18.10	43.81	18.50	43.65	18.88
	-8.5	-9.1	44.44	16.93	44.29	17.34	44.29	17.91	44.13	18.30	44.13	18.69	43.97	18.90
	-7	-7.6	44.92	17.24	44.76	17.65	44.76	18.11	44.60	18.50	44.60	18.89	44.44	19.11
	-5	-5.6	48.41	17.38	48.25	17.79	48.10	18.30	48.10	18.69	48.10	19.08	47.94	19.44
	-3	-3.7	49.05	17.68	48.89	18.08	48.73	18.53	48.73	18.93	48.57	19.32	48.57	19.54
	0	-0.7	50.00	17.90	49.84	18.33	49.68	18.69	49.68	19.08	49.68	19.48	49.52	19.67
	3	2.2	54.60	18.99	54.60	19.49	54.44	19.64	54.29	20.04	54.29	20.43	50.79	19.48
	5	4.1	68.73	21.28	64.60	21.07	60.00	20.72	57.62	20.31	55.40	20.08	50.79	18.89
7	6	69.21	21.13	64.60	20.18	60.00	19.67	57.62	19.33	55.40	19.21	50.79	18.42	
9	7.9	69.21	20.21	64.60	19.28	60.00	19.07	57.62	18.69	55.40	18.66	50.79	17.86	
11	9.8	69.21	19.56	64.60	18.88	60.00	18.42	57.62	18.14	55.40	17.99	50.79	17.20	
13	11.8	69.21	19.08	64.60	18.40	60.00	17.91	57.62	17.86	55.40	17.66	50.79	16.86	
15	13.7	69.21	18.66	64.60	17.85	60.00	17.41	57.62	17.20	55.40	17.06	50.79	16.24	
110%	-25	-25.4	39.10	15.62	38.92	15.98	38.73	16.35	38.79	16.10	38.64	16.41	38.63	16.84
	-19.8	-20	40.79	15.84	40.63	16.21	40.48	16.57	40.48	16.32	40.32	16.63	40.32	17.05
	-18.8	-19	41.11	16.08	40.95	16.44	40.79	16.81	40.79	16.34	40.63	16.81	40.63	17.10
	-16.7	-17	41.75	16.31	41.59	16.68	41.43	17.04	41.43	16.66	41.43	17.01	41.27	17.32
	-13.7	-15	42.38	16.46	42.22	16.82	42.06	17.19	42.06	16.76	42.06	17.09	41.90	17.50
	-11.8	-13	43.02	16.70	42.86	17.07	42.86	17.43	42.70	16.93	42.70	17.29	42.54	17.71
	-9.8	-11	43.65	16.71	43.49	17.07	43.49	17.43	43.33	17.24	43.33	17.50	43.17	17.94
	-9.5	-10	43.97	16.89	43.97	17.25	43.81	17.62	43.65	17.30	43.65	17.70	43.49	18.12
	-8.5	-9.1	44.29	17.07	44.13	17.44	44.13	17.80	43.97	17.47	43.97	17.88	43.81	18.33
	-7	-7.6	44.76	17.26	44.60	17.62	44.60	17.98	44.44	17.72	44.44	18.09	44.29	18.38
	-5	-5.6	48.25	17.49	48.10	17.85	47.94	18.21	47.94	17.89	47.94	18.19	46.51	18.18
	-3	-3.7	48.89	17.61	48.73	17.98	48.57	18.34	48.57	18.05	48.57	18.43	46.51	17.87
	0	-0.7	49.84	18.04	49.68	18.40	49.68	18.76	49.52	18.19	49.52	18.59	46.51	17.61
	3	2.2	54.44	18.84	54.44	19.21	54.29	19.57	52.86	18.92	50.79	18.73	46.51	17.46
	5	4.1	63.49	20.57	59.21	20.51	55.08	19.13	52.86	18.59	50.79	18.26	46.51	17.40
7	6	63.49	19.80	59.21	19.32	55.08	18.16	52.86	17.67	50.79	17.41	46.51	16.96	
9	7.9	63.49	18.91	59.21	18.28	55.08	17.51	52.86	17.23	50.79	17.04	46.51	16.67	

MDV6 VRF 50Hz



	11	9.8	63.49	18.23	59.21	17.61	55.08	17.01	52.86	16.61	50.79	16.49	46.51	16.12
	13	11.8	63.49	17.69	59.21	17.06	55.08	16.47	52.86	16.12	50.79	15.93	46.51	15.56
	15	13.7	63.49	17.19	59.21	16.49	55.08	15.92	52.86	15.57	50.79	15.39	46.51	15.02

Abbreviations:

CR: Combination ratio

TC: Total capacity (kW)

PI: Power input (compressor + outdoor fan motor) (kW)

Notes:

Shaded cells indicate rating condition.

Table 2-8.18: 16HP heating capacity (continued)

CR	Outdoor air temp.		Indoor air temp. °C DB											
			16		18		20		21		22		24	
	°C DB	°C WB	TC kW	PI kW	TC kW	PI kW	TC kW	PI kW	TC kW	PI kW	TC kW	PI kW	TC kW	PI kW
100%	-25	-25.4	39.13	19.51	38.98	19.70	38.82	19.82	38.82	20.04	38.82	20.16	38.66	20.42
	-19.8	-20	40.95	19.51	40.79	19.73	40.63	19.94	40.63	20.06	40.63	20.18	40.48	20.28
	-18.8	-19	41.59	19.56	41.43	19.78	41.27	19.99	41.27	20.08	41.27	20.20	41.11	20.11
	-16.7	-17	42.22	19.59	42.06	19.80	42.06	20.01	41.90	20.13	41.90	20.25	41.75	20.01
	-13.7	-15	42.86	19.63	42.70	19.82	42.70	20.06	42.54	20.16	42.54	20.28	42.38	19.77
	-11.8	-13	43.49	19.66	43.33	19.87	43.33	20.08	43.17	20.20	43.17	20.30	42.38	19.56
	-9.8	-11	43.81	19.68	43.81	19.89	43.65	20.11	43.65	20.20	43.49	20.32	42.38	19.53
	-9.5	-10	44.13	19.70	43.97	19.89	43.97	20.16	43.81	20.23	43.81	20.35	42.38	19.36
	-8.5	-9.1	44.60	19.73	44.60	19.92	44.44	20.22	44.29	20.25	44.29	20.37	42.38	19.07
	-7	-7.6	48.10	19.75	47.94	19.93	47.94	20.63	47.78	20.99	46.19	19.97	42.38	19.00
	-5	-5.6	48.73	19.78	48.57	19.94	48.57	20.15	48.10	20.40	46.19	19.37	42.38	18.47
	-3	-3.7	49.68	19.80	49.52	19.95	49.52	19.49	48.10	19.22	46.19	18.76	42.38	17.86
	0	-0.7	50.95	19.82	53.81	19.96	50.00	18.95	48.10	18.35	46.19	17.84	42.38	17.08
	3	2.2	54.29	19.43	53.81	19.47	50.00	18.40	48.10	17.45	46.19	16.77	42.38	16.24
	5	4.1	57.62	19.12	53.81	18.51	50.00	17.53	48.10	16.67	46.19	16.09	42.38	15.52
7	6	57.62	18.88	53.81	17.56	50.00	16.42	48.10	15.78	46.19	15.44	42.38	14.84	
9	7.9	57.62	17.80	53.81	16.63	50.00	15.96	48.10	15.39	46.19	14.98	42.38	14.36	
11	9.8	57.62	16.66	53.81	15.61	50.00	15.43	48.10	14.77	46.19	14.43	42.38	13.76	
13	11.8	57.62	15.61	53.81	15.22	50.00	14.84	48.10	14.24	46.19	13.92	42.38	13.29	
15	13.7	57.62	14.85	53.81	14.58	50.00	14.29	48.10	13.74	46.19	13.43	42.38	12.76	
90%	-25	-25.4	38.83	19.49	38.62	19.68	38.50	19.90	38.46	20.16	38.46	20.23	38.10	18.96
	-19.8	-20	40.48	19.82	40.32	20.01	40.16	20.23	40.16	20.35	40.16	20.47	38.10	18.56
	-18.8	-19	40.79	19.85	40.63	20.04	40.48	20.25	40.48	20.37	40.48	20.39	38.10	18.37
	-16.7	-17	41.43	19.87	41.27	20.06	41.27	20.28	41.11	20.39	41.11	19.99	38.10	17.99
	-13.7	-15	42.06	19.89	41.90	20.11	41.90	20.32	41.75	20.42	41.59	19.59	38.10	17.63
	-11.8	-13	42.70	19.94	42.54	20.13	42.54	20.35	42.38	20.16	41.59	19.18	38.10	17.30
	-9.8	-11	43.33	19.97	43.33	20.18	43.17	20.37	43.17	19.75	41.59	18.82	38.10	16.97
	-9.5	-10	43.65	19.99	43.65	20.18	43.49	20.39	43.33	19.56	41.59	18.63	38.10	16.80
	-8.5	-9.1	43.97	20.01	43.81	20.20	43.81	20.35	43.33	19.39	41.59	18.47	38.10	16.66
	-7	-7.6	44.44	20.04	44.44	19.93	44.29	20.06	43.33	19.13	41.59	18.20	38.10	16.42
	-5	-5.6	47.94	20.07	47.78	19.07	45.08	19.22	43.33	18.49	41.59	17.63	38.10	15.94
	-3	-3.7	48.57	20.10	48.41	18.23	45.08	18.27	43.33	17.81	41.59	17.07	38.10	15.54
	0	-0.7	49.52	20.13	48.41	17.31	45.08	17.49	43.33	16.96	41.59	16.23	38.10	15.14
	3	2.2	51.90	20.16	48.41	16.40	45.08	16.50	43.33	16.31	41.59	15.50	38.10	14.62
	5	4.1	51.90	19.66	48.41	15.59	45.08	15.75	43.33	15.47	41.59	14.78	38.10	14.04
7	6	51.90	17.09	48.41	15.31	45.08	14.73	43.33	14.16	41.59	13.61	38.10	12.49	
9	7.9	51.90	16.04	48.41	15.02	45.08	13.99	43.33	13.49	41.59	12.99	38.10	12.02	
11	9.8	51.90	15.11	48.41	14.21	45.08	13.33	43.33	12.87	41.59	12.45	38.10	11.59	
13	11.8	51.90	14.28	48.41	13.49	45.08	12.73	43.33	12.35	41.59	11.97	38.10	11.21	
15	13.7	51.90	13.68	48.41	12.99	45.08	12.30	43.33	11.97	41.59	11.64	38.10	10.95	
80%	-25	-25.4	38.78	20.67	38.62	20.93	38.80	20.30	38.41	19.33	36.98	18.51	33.81	16.78
	-19.8	-20	40.32	19.90	40.16	20.12	40.00	19.43	38.41	18.54	36.98	17.67	33.81	15.96
	-18.8	-19	40.63	19.93	40.48	20.12	40.00	19.25	38.41	18.35	36.98	17.48	33.81	15.79
	-16.7	-17	41.27	19.95	41.11	20.16	40.00	18.85	38.41	17.98	36.98	17.13	33.81	15.46
	-13.7	-15	41.90	20.00	41.75	20.19	40.00	18.47	38.41	17.62	36.98	16.80	33.81	15.18
	-11.8	-13	42.54	20.02	42.38	19.81	40.00	18.09	38.41	17.27	36.98	16.47	33.81	14.90
	-9.8	-11	43.17	20.04	43.02	19.41	40.00	17.77	38.41	16.94	36.98	16.17	33.81	14.62
	-9.5	-10	43.49	20.07	43.02	19.22	40.00	17.58	38.41	16.78	36.98	16.00	33.81	14.48
	-8.5	-9.1	43.81	20.09	43.02	19.06	40.00	17.44	38.41	16.64	36.98	15.86	33.81	14.36
	-7	-7.6	44.29	20.12	43.02	18.78	40.00	17.20	38.41	16.43	36.98	15.65	33.81	14.17
	-5	-5.6	46.19	19.72	43.02	18.16	40.00	16.66	38.41	15.91	36.98	15.20	33.81	13.77
	-3	-3.7	46.19	20.40	43.02	17.50	40.00	15.95	38.41	15.31	36.98	14.65	33.81	13.38
	0	-0.7	46.19	20.14	43.02	16.70	40.00	15.40	38.41	14.86	36.98	14.21	33.81	13.07
	3	2.2	46.19	18.61	43.02	15.75	40.00	14.53	38.41	14.33	36.98	13.68	33.81	12.56
	5	4.1	46.19	17.01	43.02	14.88	40.00	13.86	38.41	13.75	36.98	13.03	33.81	12.29
7	6	46.19	14.92	43.02	13.94	40.00	12.95	38.41	12.45	36.98	11.98	33.81	11.04	

	9	7.9	46.19	14.15	43.02	13.28	40.00	12.41	38.41	11.98	36.98	11.54	33.81	10.72
	11	9.8	46.19	13.44	43.02	12.67	40.00	11.91	38.41	11.54	36.98	11.16	33.81	10.43
	13	11.8	46.19	12.83	43.02	12.15	40.00	11.49	38.41	11.16	36.98	10.83	33.81	10.18
	15	13.7	46.19	12.38	43.02	11.77	40.00	11.19	38.41	10.90	36.98	10.60	33.81	10.01

Abbreviations:

CR: Combination ratio

TC: Total capacity (kW)

PI: Power input (compressor + outdoor fan motor) (kW)

Notes: Shaded cells indicate rating condition.

Table 2-8.18: 16HP heating capacity (continued)

CR	Outdoor air temp.		Indoor air temp. °C DB											
			16		18		20		21		22		24	
	°C DB	°C WB	TC kW	PI kW	TC kW	PI kW	TC kW	PI kW	TC kW	PI kW	TC kW	PI kW	TC kW	PI kW
70%	-25	-25.4	40.00	20.92	37.62	19.35	35.08	19.01	33.65	18.67	32.38	18.44	29.68	17.74
	-19.8	-20	40.00	19.92	37.62	18.32	35.08	17.96	33.65	17.61	32.38	17.38	29.68	16.69
	-18.8	-19	40.32	19.70	37.62	18.13	35.08	17.76	33.65	17.42	32.38	17.19	29.68	16.50
	-16.7	-17	40.32	19.30	37.62	17.78	35.08	17.46	33.65	17.11	32.38	16.88	29.68	16.19
	-13.7	-15	40.32	18.92	37.62	17.42	35.08	17.12	33.65	16.78	32.38	16.55	29.68	15.85
	-11.8	-13	40.32	18.54	37.62	17.09	35.08	16.84	33.65	16.49	32.38	16.26	29.68	15.57
	-9.8	-11	40.32	18.18	37.62	16.75	35.08	16.53	33.65	16.18	32.38	15.95	29.68	15.26
	-9.5	-10	40.32	18.01	37.62	16.61	35.08	16.11	33.65	15.76	32.38	15.53	29.68	14.84
	-8.5	-9.1	40.32	17.85	37.62	16.47	35.08	15.57	33.65	15.23	32.38	15.00	29.68	14.30
	-7	-7.6	40.32	17.61	37.62	16.23	35.08	14.90	33.65	14.55	32.38	14.32	29.68	13.63
	-5	-5.6	40.32	17.06	37.62	15.75	35.08	14.49	33.65	14.15	32.38	13.92	29.68	13.22
	-3	-3.7	40.32	16.15	37.62	15.28	35.08	14.07	33.65	13.72	32.38	13.49	29.68	12.80
	0	-0.7	40.32	15.29	37.62	14.61	35.08	13.47	33.65	13.12	32.38	12.89	29.68	12.20
	3	2.2	40.32	14.43	37.62	13.81	35.08	12.65	33.65	12.30	32.38	12.07	29.68	11.38
	5	4.1	40.32	13.77	37.62	12.93	35.08	12.17	33.65	11.83	32.38	11.60	29.68	10.90
60%	7	6	40.32	13.23	37.62	12.37	35.08	11.54	33.65	11.23	32.38	11.00	29.68	10.31
	9	7.9	40.32	12.66	37.62	11.90	35.08	11.16	33.65	10.81	32.38	10.58	29.68	9.89
	11	9.8	40.32	12.16	37.62	11.49	35.08	10.71	33.65	10.37	32.38	10.14	29.68	9.44
	13	11.8	40.32	11.71	37.62	11.02	35.08	10.20	33.65	9.85	32.38	9.62	29.68	8.93
	15	13.7	40.32	11.28	37.62	10.53	35.08	9.80	33.65	9.45	32.38	9.22	29.68	8.53
	-25	-25.4	34.60	19.50	32.38	18.43	30.00	17.58	28.89	17.18	27.62	16.46	25.40	15.60
	-19.8	-20	34.60	18.46	32.38	17.58	30.00	16.91	28.89	16.43	27.62	15.69	25.40	14.79
	-18.8	-19	34.60	17.99	32.38	16.98	30.00	16.31	28.89	15.88	27.62	15.08	25.40	14.27
	-16.7	-17	34.60	17.43	32.38	16.45	30.00	15.81	28.89	15.27	27.62	14.51	25.40	13.70
	-13.7	-15	34.60	16.82	32.38	15.96	30.00	15.32	28.89	14.70	27.62	13.94	25.40	13.13
	-11.8	-13	34.60	16.23	32.38	15.37	30.00	14.73	28.89	14.19	27.62	13.35	25.40	12.54
	-9.8	-11	34.60	15.70	32.38	14.80	30.00	14.03	28.89	13.55	27.62	12.78	25.40	12.08
	-9.5	-10	34.60	15.14	32.38	14.21	30.00	13.45	28.89	12.97	27.62	12.23	25.40	11.42
	-8.5	-9.1	34.60	14.51	32.38	13.70	30.00	12.89	28.89	12.41	27.62	11.65	25.40	10.77
	-7	-7.6	34.60	13.97	32.38	13.11	30.00	12.44	28.89	11.99	27.62	11.20	25.40	10.30
-5	-5.6	34.60	13.46	32.38	12.63	30.00	11.82	28.89	11.49	27.62	10.76	25.40	9.81	
-3	-3.7	34.60	12.99	32.38	12.13	30.00	11.29	28.89	11.03	27.62	10.28	25.40	9.47	
0	-0.7	34.60	12.47	32.38	11.65	30.00	10.79	28.89	10.50	27.62	9.77	25.40	9.29	
3	2.2	34.60	11.90	32.38	11.09	30.00	10.38	28.89	10.07	27.62	9.27	25.40	8.95	
5	4.1	34.60	11.29	32.38	10.62	30.00	9.99	28.89	9.62	27.62	9.06	25.40	8.76	
7	6	34.60	10.77	32.38	10.16	30.00	9.53	28.89	9.23	27.62	9.01	25.40	8.59	
9	7.9	34.60	10.59	32.38	9.93	30.00	9.38	28.89	9.02	27.62	8.63	25.40	8.21	
11	9.8	34.60	10.43	32.38	9.79	30.00	9.13	28.89	8.80	27.62	8.45	25.40	8.06	
13	11.8	34.60	10.11	32.38	9.46	30.00	8.85	28.89	8.61	27.62	8.28	25.40	7.88	
15	13.7	34.60	9.98	32.38	9.27	30.00	8.59	28.89	8.40	27.62	8.06	25.40	7.65	
50%	-25	-25.4	28.89	16.14	26.98	15.26	25.08	14.55	23.97	14.22	23.02	13.86	21.11	12.92
	-19.8	-20	28.89	15.29	26.98	14.56	25.08	14.00	23.97	13.60	23.02	13.22	21.11	12.25
	-18.8	-19	28.89	14.89	26.98	14.06	25.08	13.51	23.97	13.15	23.02	12.72	21.11	11.81
	-16.7	-17	28.89	14.43	26.98	13.62	25.08	13.09	23.97	12.64	23.02	12.25	21.11	11.34
	-13.7	-15	28.89	13.93	26.98	13.22	25.08	12.68	23.97	12.17	23.02	11.78	21.11	10.87
	-11.8	-13	28.89	13.43	26.98	12.73	25.08	12.19	23.97	11.75	23.02	11.29	21.11	10.38
	-9.8	-11	28.89	13.00	26.98	12.25	25.08	11.61	23.97	11.21	23.02	10.82	21.11	10.00
	-9.5	-10	28.89	12.54	26.98	11.76	25.08	11.14	23.97	10.73	23.02	10.36	21.11	9.46
	-8.5	-9.1	28.89	12.01	26.98	11.34	25.08	10.67	23.97	10.27	23.02	9.89	21.11	8.92
	-7	-7.6	28.89	11.57	26.98	10.85	25.08	10.30	23.97	9.93	23.02	9.51	21.11	8.53
	-5	-5.6	28.89	11.14	26.98	10.46	25.08	9.79	23.97	9.51	23.02	9.14	21.11	8.12
	-3	-3.7	28.89	10.75	26.98	10.04	25.08	9.35	23.97	9.13	23.02	8.75	21.11	7.84
	0	-0.7	28.89	10.32	26.98	9.64	25.08	8.93	23.97	8.69	23.02	8.33	21.11	7.69
	3	2.2	28.89	9.85	26.98	9.18	25.08	8.59	23.97	8.34	23.02	7.91	21.11	7.64
	5	4.1	28.89	9.35	26.98	8.79	25.08	8.27	23.97	7.97	23.02	7.74	21.11	7.57
7	6	28.89	8.92	26.98	8.41	25.08	7.89	23.97	7.64	23.02	7.62	21.11	7.35	

MDV6 VRF 50Hz



	9	7.9	28.89	8.77	26.98	8.22	25.08	7.76	23.97	7.47	23.02	7.30	21.11	7.12
	11	9.8	28.89	8.63	26.98	8.11	25.08	7.56	23.97	7.29	23.02	7.17	21.11	6.99
	13	11.8	28.89	8.37	26.98	7.83	25.08	7.33	23.97	7.13	23.02	7.01	21.11	6.84
	15	13.7	28.89	8.26	26.98	7.68	25.08	7.11	23.97	6.96	23.02	6.82	21.11	6.65

Abbreviations:

CR: Combination ratio

TC: Total capacity (kW)

PI: Power input (compressor + outdoor fan motor) (kW)

Notes:

Shaded cells indicate rating condition.

Table 2-8.19: 18HP heating capacity

CR	Outdoor air temp.		Indoor air temp. °C DB											
			16		18		20		21		22		24	
	°C DB	°C WB	TC kW	PI kW	TC kW	PI kW	TC kW	PI kW	TC kW	PI kW	TC kW	PI kW	TC kW	PI kW
130%	-25	-25.4	43.68	13.46	43.51	13.69	42.60	14.24	42.46	14.64	42.42	15.04	42.18	15.28
	-19.8	-20	45.92	13.82	45.74	14.11	45.56	14.82	45.39	15.23	45.39	15.63	45.21	15.83
	-18.8	-19	46.27	14.07	46.09	14.30	45.92	14.96	45.92	15.36	45.74	15.77	45.56	15.91
	-16.7	-17	46.98	14.22	46.80	14.55	46.63	15.12	46.63	15.52	46.45	15.93	46.27	16.19
	-13.7	-15	47.69	14.39	47.51	14.77	47.34	15.39	47.34	15.79	47.16	16.20	46.98	16.41
	-11.8	-13	48.40	14.63	48.22	15.01	48.04	15.68	48.04	16.08	47.87	16.48	47.87	16.66
	-9.8	-11	49.11	14.86	48.93	15.28	48.75	15.84	48.75	16.24	48.75	16.64	48.58	16.68
	-9.5	-10	49.46	15.08	49.29	15.43	49.29	16.08	49.11	16.49	49.11	16.89	48.93	16.93
	-8.5	-9.1	49.82	15.28	49.64	15.65	49.46	16.26	49.46	16.66	49.46	17.07	49.29	17.12
	-7	-7.6	50.35	15.30	50.17	15.87	50.17	16.41	50.00	16.79	50.00	17.31	49.82	17.35
	-5	-5.6	54.25	15.97	54.07	16.32	53.90	16.93	53.90	17.44	53.72	17.42	53.54	17.55
	-3	-3.7	54.96	16.36	54.78	16.58	54.60	17.20	54.60	17.72	54.43	17.65	54.25	17.78
	0	-0.7	56.02	16.84	55.85	16.74	55.67	17.42	55.67	17.90	55.49	17.91	55.49	17.92
	3	2.2	61.89	17.80	61.16	17.82	60.99	18.32	60.81	18.67	60.81	18.86	60.63	19.01
	5	4.1	76.94	21.51	73.86	21.26	72.69	21.17	69.85	20.50	67.01	20.27	61.52	19.39
	7	6	78.18	21.68	75.28	20.69	72.69	20.14	69.85	19.62	67.01	19.43	61.52	18.72
9	7.9	78.18	20.62	75.28	19.70	72.69	19.52	69.85	19.26	67.01	18.94	61.52	18.29	
11	9.8	78.18	19.63	75.28	18.89	72.69	18.85	69.85	18.61	67.01	18.38	61.52	17.59	
13	11.8	78.18	18.67	75.28	18.33	72.69	18.33	69.85	18.29	67.01	17.97	61.52	17.27	
15	13.7	78.18	18.09	75.28	17.92	72.69	17.82	69.85	17.57	67.01	17.46	61.52	16.63	
120%	-25	-25.4	43.26	14.67	43.08	15.20	43.04	15.74	42.90	16.12	42.71	16.50	42.58	16.73
	-19.8	-20	45.87	15.07	45.69	15.57	45.51	16.02	45.51	16.40	45.33	16.78	45.16	17.07
	-18.8	-19	46.22	15.28	46.04	15.59	45.87	16.29	45.87	16.68	45.69	17.06	45.51	17.26
	-16.7	-17	46.93	15.51	46.76	15.82	46.58	16.52	46.58	16.90	46.40	17.28	46.40	17.32
	-13.7	-15	47.64	15.70	47.47	16.14	47.29	16.59	47.29	16.98	47.29	17.36	47.11	17.50
	-11.8	-13	48.36	15.94	48.18	16.31	48.08	16.81	48.00	17.19	48.00	17.57	47.82	17.69
	-9.8	-11	49.07	16.03	48.89	16.43	48.89	17.00	48.71	17.38	48.71	17.76	48.53	18.02
	-9.5	-10	49.42	16.21	49.24	16.55	49.24	17.12	49.07	17.50	49.07	17.88	48.89	18.25
	-8.5	-9.1	49.78	16.37	49.60	16.76	49.60	17.31	49.42	17.69	49.42	18.07	49.24	18.27
	-7	-7.6	50.31	16.66	50.13	17.06	50.13	17.50	49.96	17.88	49.96	18.26	49.78	18.48
	-5	-5.6	54.22	16.80	54.04	17.20	53.87	17.69	53.87	18.07	53.87	18.45	53.69	18.79
	-3	-3.7	54.93	17.09	54.76	17.48	54.58	17.91	54.58	18.30	54.40	18.68	54.40	18.89
	0	-0.7	56.00	17.31	55.82	17.72	55.64	18.07	55.64	18.45	55.64	18.83	55.47	19.02
	3	2.2	61.16	18.36	61.16	18.84	60.98	18.99	60.80	19.37	60.80	19.75	56.89	18.83
	5	4.1	76.98	20.57	72.36	20.36	67.20	20.03	64.53	19.63	62.04	19.41	56.89	18.26
	7	6	77.51	20.43	72.36	19.51	67.20	19.02	64.53	18.68	62.04	18.57	56.89	17.81
9	7.9	77.51	19.54	72.36	18.64	67.20	18.44	64.53	18.07	62.04	18.04	56.89	17.26	
11	9.8	77.51	18.90	72.36	18.25	67.20	17.81	64.53	17.54	62.04	17.39	56.89	16.62	
13	11.8	77.51	18.45	72.36	17.78	67.20	17.31	64.53	17.26	62.04	17.07	56.89	16.30	
15	13.7	77.51	18.04	72.36	17.26	67.20	16.83	64.53	16.63	62.04	16.49	56.89	15.70	
110%	-25	-25.4	43.79	15.10	43.59	15.45	43.38	15.80	43.44	15.56	43.28	15.86	43.26	16.27
	-19.8	-20	45.69	15.32	45.51	15.67	45.33	16.02	45.33	15.78	45.16	16.07	45.16	16.48
	-18.8	-19	46.04	15.55	45.87	15.90	45.69	16.25	45.69	15.80	45.51	16.25	45.51	16.53
	-16.7	-17	46.76	15.77	46.58	16.12	46.40	16.47	46.40	16.10	46.40	16.44	46.22	16.74
	-13.7	-15	47.47	15.91	47.29	16.26	47.11	16.61	47.11	16.20	47.11	16.52	46.93	16.92
	-11.8	-13	48.18	16.15	48.00	16.50	48.00	16.85	47.82	16.37	47.82	16.71	47.64	17.12
	-9.8	-11	48.89	16.15	48.71	16.50	48.71	16.85	48.53	16.67	48.53	16.91	48.36	17.34
	-9.5	-10	49.24	16.33	49.24	16.68	49.07	17.03	48.89	16.73	48.89	17.11	48.71	17.52
	-8.5	-9.1	49.60	16.50	49.42	16.86	49.42	17.21	49.24	16.88	49.24	17.29	49.07	17.71
	-7	-7.6	50.13	16.68	49.96	17.03	49.96	17.38	49.78	17.13	49.78	17.48	49.60	17.76
	-5	-5.6	54.04	16.90	53.87	17.25	53.69	17.60	53.69	17.30	53.69	17.58	52.09	17.57
	-3	-3.7	54.76	17.03	54.58	17.38	54.40	17.73	54.40	17.45	54.40	17.81	52.09	17.27
	0	-0.7	55.82	17.44	55.64	17.79	55.64	18.14	55.47	17.59	55.47	17.97	52.09	17.03
	3	2.2	60.98	18.22	60.98	18.57	60.80	18.92	59.20	18.29	56.89	18.11	52.09	16.88
	5	4.1	71.11	19.88	66.31	19.82	61.69	18.49	59.20	17.97	56.89	17.65	52.09	16.82

	7	6	71.11	19.14	66.31	18.67	61.69	17.55	59.20	17.08	56.89	16.83	52.09	16.39
	9	7.9	71.11	18.28	66.31	17.67	61.69	16.93	59.20	16.66	56.89	16.47	52.09	16.11
	11	9.8	71.11	17.62	66.31	17.02	61.69	16.44	59.20	16.05	56.89	15.94	52.09	15.58
	13	11.8	71.11	17.10	66.31	16.49	61.69	15.92	59.20	15.59	56.89	15.40	52.09	15.05
	15	13.7	71.11	16.62	66.31	15.94	61.69	15.39	59.20	15.05	56.89	14.87	52.09	14.51

Abbreviations:

CR: Combination ratio

TC: Total capacity (kW)

PI: Power input (compressor + outdoor fan motor) (kW)

Notes: Shaded cells indicate rating condition.

Table 2-8.19: 18HP heating capacity (continued)

CR	Outdoor air temp.		Indoor air temp. °C DB											
			16		18		20		21		22		24	
	°C DB	°C WB	TC kW	PI kW	TC kW	PI kW	TC kW	PI kW	TC kW	PI kW	TC kW	PI kW	TC kW	PI kW
100%	-25	-25.4	43.83	18.86	43.65	19.05	43.48	19.16	43.48	19.37	43.48	19.48	43.30	19.74
	-19.8	-20	45.87	18.86	45.69	19.07	45.51	19.28	45.51	19.39	45.51	19.51	45.33	19.60
	-18.8	-19	46.58	18.91	46.40	19.12	46.22	19.32	46.22	19.42	46.22	19.53	46.04	19.44
	-16.7	-17	47.29	18.93	47.11	19.14	47.11	19.35	46.93	19.46	46.93	19.58	46.76	19.35
	-13.7	-15	48.00	18.98	47.82	19.16	47.82	19.39	47.64	19.48	47.64	19.60	47.47	19.11
	-11.8	-13	48.71	19.00	48.53	19.21	48.53	19.42	48.36	19.53	48.36	19.62	47.47	18.90
	-9.8	-11	49.07	19.02	49.07	19.23	48.89	19.44	48.89	19.53	48.71	19.65	47.47	18.88
	-9.5	-10	49.42	19.05	49.24	19.23	49.24	19.49	49.07	19.55	49.07	19.67	47.47	18.72
	-8.5	-9.1	49.96	19.07	49.96	19.25	49.78	19.55	49.60	19.58	49.60	19.69	47.47	18.43
	-7	-7.6	53.87	19.09	53.69	19.26	53.69	19.94	53.51	20.29	51.73	19.30	47.47	18.37
	-5	-5.6	54.58	19.12	54.40	19.27	54.40	19.48	53.87	19.72	51.73	18.72	47.47	17.85
	-3	-3.7	55.64	19.14	55.47	19.28	55.47	18.84	53.87	18.58	51.73	18.13	47.47	17.26
	0	-0.7	57.07	19.16	60.27	19.30	56.00	18.32	53.87	17.73	51.73	17.24	47.47	16.51
	3	2.2	60.80	18.78	60.27	18.82	56.00	17.79	53.87	16.87	51.73	16.21	47.47	15.70
	5	4.1	64.53	18.48	60.27	17.90	56.00	16.95	53.87	16.11	51.73	15.56	47.47	15.00
	7	6	64.53	18.25	60.27	16.98	56.00	15.87	53.87	15.25	51.73	14.92	47.47	14.34
9	7.9	64.53	17.21	60.27	16.08	56.00	15.43	53.87	14.88	51.73	14.48	47.47	13.88	
11	9.8	64.53	16.10	60.27	15.09	56.00	14.92	53.87	14.28	51.73	13.95	47.47	13.30	
13	11.8	64.53	15.09	60.27	14.72	56.00	14.34	53.87	13.77	51.73	13.46	47.47	12.84	
15	13.7	64.53	14.35	60.27	14.09	56.00	13.81	53.87	13.28	51.73	12.98	47.47	12.34	
90%	-25	-25.4	43.49	18.84	43.26	19.02	43.11	19.24	43.08	19.48	43.08	19.55	42.67	18.33
	-19.8	-20	45.33	19.16	45.16	19.35	44.98	19.55	44.98	19.67	44.98	19.78	42.67	17.94
	-18.8	-19	45.69	19.19	45.51	19.37	45.33	19.58	45.33	19.69	45.33	19.71	42.67	17.76
	-16.7	-17	46.40	19.21	46.22	19.39	46.22	19.60	46.04	19.71	46.04	19.32	42.67	17.39
	-13.7	-15	47.11	19.23	46.93	19.44	46.93	19.65	46.76	19.74	46.58	18.93	42.67	17.05
	-11.8	-13	47.82	19.28	47.64	19.46	47.64	19.67	47.47	19.48	46.58	18.54	42.67	16.72
	-9.8	-11	48.53	19.30	48.53	19.51	48.36	19.69	48.36	19.09	46.58	18.20	42.67	16.40
	-9.5	-10	48.89	19.32	48.89	19.51	48.71	19.71	48.53	18.91	46.58	18.01	42.67	16.24
	-8.5	-9.1	49.24	19.35	49.07	19.53	49.07	19.67	48.53	18.75	46.58	17.85	42.67	16.10
	-7	-7.6	49.78	19.37	49.78	19.27	49.60	19.39	48.53	18.49	46.58	17.60	42.67	15.87
	-5	-5.6	53.69	19.40	53.51	18.43	50.49	18.58	48.53	17.87	46.58	17.05	42.67	15.41
	-3	-3.7	54.40	19.43	54.22	17.62	50.49	17.66	48.53	17.21	46.58	16.50	42.67	15.02
	0	-0.7	55.47	19.46	54.22	16.74	50.49	16.91	48.53	16.39	46.58	15.69	42.67	14.63
	3	2.2	58.13	19.48	54.22	15.86	50.49	15.95	48.53	15.77	46.58	14.99	42.67	14.14
	5	4.1	58.13	19.00	54.22	15.07	50.49	15.23	48.53	14.96	46.58	14.29	42.67	13.57
	7	6	58.13	16.52	54.22	14.80	50.49	14.24	48.53	13.69	46.58	13.16	42.67	12.08
9	7.9	58.13	15.50	54.22	14.52	50.49	13.53	48.53	13.04	46.58	12.56	42.67	11.62	
11	9.8	58.13	14.61	54.22	13.73	50.49	12.88	48.53	12.44	46.58	12.03	42.67	11.20	
13	11.8	58.13	13.80	54.22	13.04	50.49	12.31	48.53	11.94	46.58	11.57	42.67	10.83	
15	13.7	58.13	13.23	54.22	12.56	50.49	11.89	48.53	11.57	46.58	11.25	42.67	10.58	
80%	-25	-25.4	43.43	19.98	43.25	20.23	43.46	19.62	43.02	18.69	41.42	17.89	37.87	16.22
	-19.8	-20	45.16	19.24	44.98	19.44	44.80	18.79	43.02	17.92	41.42	17.08	37.87	15.42
	-18.8	-19	45.51	19.26	45.33	19.44	44.80	18.60	43.02	17.74	41.42	16.90	37.87	15.26
	-16.7	-17	46.22	19.29	46.04	19.49	44.80	18.22	43.02	17.38	41.42	16.56	37.87	14.95
	-13.7	-15	46.93	19.33	46.76	19.51	44.80	17.85	43.02	17.04	41.42	16.24	37.87	14.67
	-11.8	-13	47.64	19.35	47.47	19.15	44.80	17.49	43.02	16.70	41.42	15.92	37.87	14.40
	-9.8	-11	48.36	19.38	48.18	18.76	44.80	17.17	43.02	16.38	41.42	15.63	37.87	14.13
	-9.5	-10	48.71	19.40	48.18	18.58	44.80	16.99	43.02	16.22	41.42	15.47	37.87	13.99
	-8.5	-9.1	49.07	19.42	48.18	18.42	44.80	16.85	43.02	16.08	41.42	15.33	37.87	13.88
	-7	-7.6	49.60	19.44	48.18	18.15	44.80	16.63	43.02	15.88	41.42	15.13	37.87	13.70
	-5	-5.6	51.73	19.06	48.18	17.56	44.80	16.11	43.02	15.38	41.42	14.70	37.87	13.31
	-3	-3.7	51.73	19.72	48.18	16.92	44.80	15.42	43.02	14.80	41.42	14.16	37.87	12.93
	0	-0.7	51.73	19.46	48.18	16.14	44.80	14.89	43.02	14.36	41.42	13.74	37.87	12.64
	3	2.2	51.73	17.99	48.18	15.23	44.80	14.04	43.02	13.86	41.42	13.22	37.87	12.14
	5	4.1	51.73	16.45	48.18	14.39	44.80	13.40	43.02	13.29	41.42	12.60	37.87	11.88

MDV6 VRF 50Hz



	7	6	51.73	14.42	48.18	13.47	44.80	12.52	43.02	12.04	41.42	11.58	37.87	10.68
	9	7.9	51.73	13.67	48.18	12.83	44.80	11.99	43.02	11.58	41.42	11.15	37.87	10.36
	11	9.8	51.73	12.99	48.18	12.24	44.80	11.52	43.02	11.15	41.42	10.79	37.87	10.09
	13	11.8	51.73	12.40	48.18	11.74	44.80	11.11	43.02	10.79	41.42	10.47	37.87	9.84
	15	13.7	51.73	11.97	48.18	11.38	44.80	10.81	43.02	10.54	41.42	10.24	37.87	9.68

Abbreviations:

CR: Combination ratio

TC: Total capacity (kW)

PI: Power input (compressor + outdoor fan motor) (kW)

Notes:

Shaded cells indicate rating condition.

Table 2-8.19: 18HP heating capacity (continued)

CR	Outdoor air temp.		Indoor air temp. °C DB											
			16		18		20		21		22		24	
	°C DB	°C WB	TC kW	PI kW	TC kW	PI kW	TC kW	PI kW	TC kW	PI kW	TC kW	PI kW	TC kW	PI kW
70%	-25	-25.4	44.80	20.22	42.13	18.70	39.29	18.38	37.69	18.05	36.27	17.82	33.24	17.15
	-19.8	-20	44.80	19.25	42.13	17.71	39.29	17.36	37.69	17.02	36.27	16.80	33.24	16.13
	-18.8	-19	45.16	19.05	42.13	17.53	39.29	17.17	37.69	16.84	36.27	16.61	33.24	15.94
	-16.7	-17	45.16	18.66	42.13	17.18	39.29	16.87	37.69	16.54	36.27	16.32	33.24	15.65
	-13.7	-15	45.16	18.29	42.13	16.84	39.29	16.55	37.69	16.22	36.27	15.99	33.24	15.32
	-11.8	-13	45.16	17.92	42.13	16.52	39.29	16.28	37.69	15.94	36.27	15.72	33.24	15.05
	-9.8	-11	45.16	17.57	42.13	16.19	39.29	15.98	37.69	15.64	36.27	15.42	33.24	14.75
	-9.5	-10	45.16	17.41	42.13	16.06	39.29	15.57	37.69	15.24	36.27	15.02	33.24	14.35
	-8.5	-9.1	45.16	17.25	42.13	15.92	39.29	15.05	37.69	14.72	36.27	14.50	33.24	13.83
	-7	-7.6	45.16	17.02	42.13	15.69	39.29	14.40	37.69	14.07	36.27	13.84	33.24	13.17
	-5	-5.6	45.16	16.49	42.13	15.23	39.29	14.01	37.69	13.67	36.27	13.45	33.24	12.78
	-3	-3.7	45.16	15.61	42.13	14.77	39.29	13.60	37.69	13.27	36.27	13.04	33.24	12.37
	0	-0.7	45.16	14.78	42.13	14.12	39.29	13.02	37.69	12.69	36.27	12.46	33.24	11.79
	3	2.2	45.16	13.95	42.13	13.35	39.29	12.23	37.69	11.89	36.27	11.67	33.24	11.00
	5	4.1	45.16	13.31	42.13	12.50	39.29	11.77	37.69	11.43	36.27	11.21	33.24	10.54
7	6	45.16	12.79	42.13	11.96	39.29	11.16	37.69	10.85	36.27	10.63	33.24	9.96	
9	7.9	45.16	12.24	42.13	11.50	39.29	10.79	37.69	10.45	36.27	10.23	33.24	9.56	
11	9.8	45.16	11.75	42.13	11.11	39.29	10.36	37.69	10.02	36.27	9.80	33.24	9.13	
13	11.8	45.16	11.32	42.13	10.65	39.29	9.86	37.69	9.52	36.27	9.30	33.24	8.63	
15	13.7	45.16	10.91	42.13	10.18	39.29	9.47	37.69	9.14	36.27	8.91	33.24	8.24	
60%	-25	-25.4	38.76	18.85	36.27	17.82	33.60	16.99	32.36	16.61	30.93	15.91	28.44	15.08
	-19.8	-20	38.76	17.85	36.27	17.00	33.60	16.35	32.36	15.88	30.93	15.17	28.44	14.30
	-18.8	-19	38.76	17.39	36.27	16.41	33.60	15.77	32.36	15.35	30.93	14.57	28.44	13.79
	-16.7	-17	38.76	16.84	36.27	15.91	33.60	15.29	32.36	14.76	30.93	14.03	28.44	13.24
	-13.7	-15	38.76	16.26	36.27	15.43	33.60	14.81	32.36	14.21	30.93	13.48	28.44	12.69
	-11.8	-13	38.76	15.69	36.27	14.86	33.60	14.24	32.36	13.72	30.93	12.91	28.44	12.12
	-9.8	-11	38.76	15.18	36.27	14.31	33.60	13.56	32.36	13.09	30.93	12.36	28.44	11.68
	-9.5	-10	38.76	14.64	36.27	13.73	33.60	13.00	32.36	12.53	30.93	11.82	28.44	11.04
	-8.5	-9.1	38.76	14.03	36.27	13.24	33.60	12.46	32.36	12.00	30.93	11.27	28.44	10.41
	-7	-7.6	38.76	13.51	36.27	12.67	33.60	12.03	32.36	11.59	30.93	10.83	28.44	9.96
	-5	-5.6	38.76	13.01	36.27	12.21	33.60	11.43	32.36	11.11	30.93	10.40	28.44	9.48
	-3	-3.7	38.76	12.55	36.27	11.72	33.60	10.92	32.36	10.67	30.93	9.94	28.44	9.15
	0	-0.7	38.76	12.05	36.27	11.26	33.60	10.43	32.36	10.15	30.93	9.45	28.44	8.98
	3	2.2	38.76	11.50	36.27	10.72	33.60	10.03	32.36	9.74	30.93	8.96	28.44	8.65
	5	4.1	38.76	10.91	36.27	10.26	33.60	9.66	32.36	9.30	30.93	8.76	28.44	8.47
7	6	38.76	10.41	36.27	9.82	33.60	9.21	32.36	8.93	30.93	8.71	28.44	8.30	
9	7.9	38.76	10.23	36.27	9.60	33.60	9.06	32.36	8.72	30.93	8.34	28.44	7.94	
11	9.8	38.76	10.08	36.27	9.46	33.60	8.83	32.36	8.51	30.93	8.17	28.44	7.79	
13	11.8	38.76	9.77	36.27	9.15	33.60	8.55	32.36	8.32	30.93	8.00	28.44	7.61	
15	13.7	38.76	9.65	36.27	8.96	33.60	8.30	32.36	8.12	30.93	7.79	28.44	7.40	
50%	-25	-25.4	32.36	15.60	30.22	14.75	28.09	14.07	26.84	13.75	25.78	13.40	23.64	12.49
	-19.8	-20	32.36	14.78	30.22	14.07	28.09	13.53	26.84	13.15	25.78	12.78	23.64	11.84
	-18.8	-19	32.36	14.40	30.22	13.59	28.09	13.06	26.84	12.71	25.78	12.29	23.64	11.42
	-16.7	-17	32.36	13.95	30.22	13.17	28.09	12.65	26.84	12.22	25.78	11.84	23.64	10.96
	-13.7	-15	32.36	13.46	30.22	12.78	28.09	12.26	26.84	11.76	25.78	11.39	23.64	10.51
	-11.8	-13	32.36	12.99	30.22	12.30	28.09	11.79	26.84	11.36	25.78	10.91	23.64	10.04
	-9.8	-11	32.36	12.57	30.22	11.85	28.09	11.22	26.84	10.84	25.78	10.46	23.64	9.67
	-9.5	-10	32.36	12.12	30.22	11.37	28.09	10.76	26.84	10.38	25.78	10.01	23.64	9.14
	-8.5	-9.1	32.36	11.61	30.22	10.96	28.09	10.31	26.84	9.93	25.78	9.56	23.64	8.62
	-7	-7.6	32.36	11.18	30.22	10.49	28.09	9.96	26.84	9.60	25.78	9.19	23.64	8.24
	-5	-5.6	32.36	10.77	30.22	10.11	28.09	9.46	26.84	9.20	25.78	8.84	23.64	7.85
	-3	-3.7	32.36	10.39	30.22	9.71	28.09	9.04	26.84	8.83	25.78	8.46	23.64	7.57
	0	-0.7	32.36	9.98	30.22	9.32	28.09	8.63	26.84	8.40	25.78	8.05	23.64	7.43
3	2.2	32.36	9.52	30.22	8.87	28.09	8.30	26.84	8.06	25.78	7.65	23.64	7.39	

	5	4.1	32.36	9.03	30.22	8.50	28.09	8.00	26.84	7.70	25.78	7.48	23.64	7.31
	7	6	32.36	8.62	30.22	8.13	28.09	7.62	26.84	7.39	25.78	7.36	23.64	7.10
	9	7.9	32.36	8.47	30.22	7.95	28.09	7.50	26.84	7.22	25.78	7.06	23.64	6.88
	11	9.8	32.36	8.35	30.22	7.84	28.09	7.31	26.84	7.04	25.78	6.93	23.64	6.75
	13	11.8	32.36	8.09	30.22	7.57	28.09	7.08	26.84	6.89	25.78	6.78	23.64	6.61
	15	13.7	32.36	7.99	30.22	7.42	28.09	6.87	26.84	6.72	25.78	6.59	23.64	6.43

Abbreviations:

CR: Combination ratio

TC: Total capacity (kW)

PI: Power input (compressor + outdoor fan motor) (kW)

Notes: Shaded cells indicate rating condition.

Table 2-8.20: 20HP heating capacity

CR	Outdoor air temp.		Indoor air temp. °C DB											
			16		18		20		21		22		24	
	°C DB	°C WB	TC kW	PI kW	TC kW	PI kW	TC kW	PI kW	TC kW	PI kW	TC kW	PI kW	TC kW	PI kW
130%	-25	-25.4	49.14	15.35	48.94	15.61	47.93	16.23	47.77	16.69	47.73	17.15	47.45	17.42
	-19.8	-20	51.66	15.75	51.46	16.09	51.26	16.90	51.06	17.36	51.06	17.82	50.86	18.04
	-18.8	-19	52.06	16.03	51.86	16.30	51.66	17.05	51.66	17.51	51.46	17.97	51.26	18.14
	-16.7	-17	52.85	16.21	52.65	16.59	52.46	17.24	52.46	17.70	52.26	18.16	52.06	18.45
	-13.7	-15	53.65	16.40	53.45	16.84	53.25	17.54	53.25	18.00	53.05	18.46	52.85	18.71
	-11.8	-13	54.45	16.68	54.25	17.11	54.05	17.87	54.05	18.33	53.85	18.79	53.85	18.99
	-9.8	-11	55.25	16.94	55.05	17.42	54.85	18.06	54.85	18.51	54.85	18.97	54.65	19.01
	-9.5	-10	55.65	17.19	55.45	17.59	55.45	18.33	55.25	18.79	55.25	19.25	55.05	19.30
	-8.5	-9.1	56.05	17.42	55.85	17.84	55.65	18.54	55.65	18.99	55.65	19.45	55.45	19.52
	-7	-7.6	56.64	17.45	56.44	18.09	56.44	18.71	56.24	19.14	56.24	19.73	56.05	19.77
	-5	-5.6	61.03	18.21	60.83	18.60	60.63	19.29	60.63	19.88	60.43	19.86	60.23	20.01
	-3	-3.7	61.83	18.65	61.63	18.90	61.43	19.61	61.43	20.19	61.23	20.11	61.03	20.27
	0	-0.7	63.03	19.19	62.83	19.08	62.63	19.86	62.63	20.41	62.43	20.42	62.43	20.43
	3	2.2	69.63	20.29	68.81	20.32	68.61	20.89	68.41	21.28	68.41	21.49	68.21	21.67
	5	4.1	86.56	24.52	83.09	24.23	81.77	24.13	78.58	23.36	75.39	23.10	69.21	22.10
7	6	87.96	24.72	84.69	23.58	81.77	22.95	78.58	22.36	75.39	22.15	69.21	21.34	
9	7.9	87.96	23.51	84.69	22.45	81.77	22.25	78.58	21.95	75.39	21.58	69.21	20.85	
11	9.8	87.96	22.37	84.69	21.53	81.77	21.49	78.58	21.21	75.39	20.95	69.21	20.05	
13	11.8	87.96	21.28	84.69	20.90	81.77	20.89	78.58	20.85	75.39	20.49	69.21	19.69	
15	13.7	87.96	20.62	84.69	20.43	81.77	20.31	78.58	20.03	75.39	19.90	69.21	18.96	
120%	-25	-25.4	48.67	16.72	48.47	17.33	48.42	17.94	48.27	18.37	48.05	18.81	47.90	19.07
	-19.8	-20	51.60	17.17	51.40	17.75	51.20	18.26	51.20	18.70	51.00	19.13	50.80	19.46
	-18.8	-19	52.00	17.42	51.80	17.78	51.60	18.57	51.60	19.01	51.40	19.44	51.20	19.67
	-16.7	-17	52.80	17.68	52.60	18.04	52.40	18.83	52.40	19.26	52.20	19.69	52.20	19.75
	-13.7	-15	53.60	17.90	53.40	18.40	53.20	18.92	53.20	19.35	53.20	19.78	53.00	19.95
	-11.8	-13	54.40	18.17	54.20	18.59	54.09	19.16	54.00	19.60	54.00	20.03	53.80	20.17
	-9.8	-11	55.20	18.27	55.00	18.72	55.00	19.38	54.80	19.81	54.80	20.25	54.60	20.54
	-9.5	-10	55.60	18.48	55.40	18.86	55.40	19.51	55.20	19.95	55.20	20.38	55.00	20.80
	-8.5	-9.1	56.00	18.66	55.80	19.11	55.80	19.73	55.60	20.17	55.60	20.60	55.40	20.82
	-7	-7.6	56.60	18.99	56.40	19.45	56.40	19.95	56.20	20.39	56.20	20.82	56.00	21.06
	-5	-5.6	61.00	19.15	60.80	19.60	60.60	20.16	60.60	20.59	60.60	21.03	60.40	21.42
	-3	-3.7	61.80	19.48	61.60	19.92	61.40	20.42	61.40	20.85	61.20	21.29	61.20	21.53
	0	-0.7	63.00	19.73	62.80	20.20	62.60	20.59	62.60	21.03	62.60	21.46	62.40	21.68
	3	2.2	68.80	20.92	68.80	21.47	68.60	21.64	68.40	22.08	68.40	22.51	64.00	21.46
	5	4.1	86.60	23.45	81.40	23.21	75.60	22.83	72.60	22.37	69.80	22.13	64.00	20.81
7	6	87.20	23.29	81.40	22.24	75.60	21.68	72.60	21.29	69.80	21.17	64.00	20.30	
9	7.9	87.20	22.27	81.40	21.25	75.60	21.02	72.60	20.60	69.80	20.56	64.00	19.68	
11	9.8	87.20	21.55	81.40	20.80	75.60	20.30	72.60	19.99	69.80	19.82	64.00	18.95	
13	11.8	87.20	21.03	81.40	20.27	75.60	19.73	72.60	19.68	69.80	19.46	64.00	18.58	
15	13.7	87.20	20.56	81.40	19.67	75.60	19.18	72.60	18.96	69.80	18.80	64.00	17.89	
110%	-25	-25.4	49.27	17.21	49.04	17.61	48.80	18.01	48.87	17.74	48.69	18.08	48.67	18.55
	-19.8	-20	51.40	17.46	51.20	17.86	51.00	18.26	51.00	17.98	50.80	18.32	50.80	18.78
	-18.8	-19	51.80	17.72	51.60	18.12	51.40	18.52	51.40	18.01	51.20	18.52	51.20	18.84
	-16.7	-17	52.60	17.98	52.40	18.38	52.20	18.78	52.20	18.36	52.20	18.74	52.00	19.09
	-13.7	-15	53.40	18.14	53.20	18.54	53.00	18.94	53.00	18.47	53.00	18.83	52.80	19.29
	-11.8	-13	54.20	18.40	54.00	18.80	54.00	19.21	53.80	18.66	53.80	19.05	53.60	19.51
	-9.8	-11	55.00	18.41	54.80	18.81	54.80	19.21	54.60	19.00	54.60	19.28	54.40	19.77
	-9.5	-10	55.40	18.61	55.40	19.01	55.20	19.41	55.00	19.07	55.00	19.50	54.80	19.97
	-8.5	-9.1	55.80	18.81	55.60	19.21	55.60	19.61	55.40	19.25	55.40	19.70	55.20	20.19
	-7	-7.6	56.40	19.02	56.20	19.42	56.20	19.82	56.00	19.53	56.00	19.93	55.80	20.25
	-5	-5.6	60.80	19.27	60.60	19.67	60.40	20.07	60.40	19.72	60.40	20.04	58.60	20.03
	-3	-3.7	61.60	19.41	61.40	19.81	61.20	20.21	61.20	19.89	61.20	20.31	58.60	19.69
	0	-0.7	62.80	19.88	62.60	20.28	62.60	20.68	62.40	20.05	62.40	20.49	58.60	19.41
	3	2.2	68.60	20.76	68.60	21.16	68.40	21.56	66.60	20.85	64.00	20.64	58.60	19.24

MDV6 VRF 50Hz



5	4.1	80.00	22.66	74.60	22.60	69.40	21.07	66.60	20.48	64.00	20.12	58.60	19.17
7	6	80.00	21.82	74.60	21.29	69.40	20.01	66.60	19.47	64.00	19.18	58.60	18.69
9	7.9	80.00	20.83	74.60	20.14	69.40	19.30	66.60	18.99	64.00	18.78	58.60	18.37
11	9.8	80.00	20.09	74.60	19.40	69.40	18.74	66.60	18.30	64.00	18.17	58.60	17.76
13	11.8	80.00	19.50	74.60	18.80	69.40	18.14	66.60	17.77	64.00	17.55	58.60	17.15
15	13.7	80.00	18.94	74.60	18.17	69.40	17.54	66.60	17.16	64.00	16.95	58.60	16.54

Abbreviations:

CR: Combination ratio

TC: Total capacity (kW)

PI: Power input (compressor + outdoor fan motor) (kW)

Notes:

Shaded cells indicate rating condition.

Table 2-8.20: 20HP heating capacity (continued)

CR	Outdoor air temp.		Indoor air temp. °C DB											
			16		18		20		21		22		24	
	°C DB	°C WB	TC	PI	TC	PI	TC	PI	TC	PI	TC	PI	TC	PI
100%	-25	-25.4	49.31	21.50	49.11	21.71	48.91	21.84	48.91	22.08	48.91	22.21	48.71	22.50
	-19.8	-20	51.60	21.50	51.40	21.74	51.20	21.97	51.20	22.10	51.20	22.24	51.00	22.34
	-18.8	-19	52.40	21.55	52.20	21.79	52.00	22.03	52.00	22.13	52.00	22.26	51.80	22.16
	-16.7	-17	53.20	21.58	53.00	21.82	53.00	22.05	52.80	22.18	52.80	22.31	52.60	22.05
	-13.7	-15	54.00	21.63	53.80	21.84	53.80	22.10	53.60	22.21	53.60	22.34	53.40	21.79
	-11.8	-13	54.80	21.66	54.60	21.90	54.60	22.13	54.40	22.26	54.40	22.37	53.40	21.55
	-9.8	-11	55.20	21.69	55.20	21.92	55.00	22.16	55.00	22.26	54.80	22.39	53.40	21.52
	-9.5	-10	55.60	21.71	55.40	21.92	55.40	22.21	55.20	22.29	55.20	22.42	53.40	21.34
	-8.5	-9.1	56.20	21.74	56.20	21.95	56.00	22.28	55.80	22.31	55.80	22.45	53.40	21.01
	-7	-7.6	60.60	21.76	60.40	21.96	60.40	22.74	60.20	23.13	58.20	22.00	53.40	20.94
	-5	-5.6	61.40	21.79	61.20	21.97	61.20	22.21	60.60	22.47	58.20	21.34	53.40	20.35
	-3	-3.7	62.60	21.82	62.40	21.98	62.40	21.48	60.60	21.18	58.20	20.67	53.40	19.68
	0	-0.7	64.20	21.84	67.80	22.00	63.00	20.88	60.60	20.21	58.20	19.66	53.40	18.82
	3	2.2	68.40	21.41	67.80	21.45	63.00	20.28	60.60	19.23	58.20	18.48	53.40	17.89
	5	4.1	72.60	21.06	67.80	20.40	63.00	19.32	60.60	18.37	58.20	17.73	53.40	17.10
7	6	72.60	20.80	67.80	19.35	63.00	18.09	60.60	17.38	58.20	17.01	53.40	16.35	
9	7.9	72.60	19.61	67.80	18.33	63.00	17.59	60.60	16.96	58.20	16.51	53.40	15.82	
11	9.8	72.60	18.36	67.80	17.20	63.00	17.00	60.60	16.27	58.20	15.90	53.40	15.16	
13	11.8	72.60	17.20	67.80	16.77	63.00	16.35	60.60	15.69	58.20	15.34	53.40	14.64	
15	13.7	72.60	16.36	67.80	16.07	63.00	15.74	60.60	15.14	58.20	14.79	53.40	14.07	
90%	-25	-25.4	48.93	21.48	48.66	21.68	48.50	21.93	48.46	22.21	48.46	22.29	48.00	20.89
	-19.8	-20	51.00	21.84	50.80	22.05	50.60	22.29	50.60	22.42	50.60	22.55	48.00	20.45
	-18.8	-19	51.40	21.87	51.20	22.08	51.00	22.31	51.00	22.45	51.00	22.47	48.00	20.24
	-16.7	-17	52.20	21.90	52.00	22.10	52.00	22.34	51.80	22.47	51.80	22.03	48.00	19.82
	-13.7	-15	53.00	21.92	52.80	22.16	52.80	22.39	52.60	22.50	52.40	21.58	48.00	19.43
	-11.8	-13	53.80	21.97	53.60	22.18	53.60	22.42	53.40	22.21	52.40	21.13	48.00	19.06
	-9.8	-11	54.60	22.00	54.60	22.24	54.40	22.45	54.40	21.76	52.40	20.74	48.00	18.70
	-9.5	-10	55.00	22.03	55.00	22.24	54.80	22.47	54.60	21.55	52.40	20.53	48.00	18.51
	-8.5	-9.1	55.40	22.05	55.20	22.26	55.20	22.42	54.60	21.37	52.40	20.35	48.00	18.36
	-7	-7.6	56.00	22.08	56.00	22.16	55.80	22.10	54.60	21.08	52.40	20.06	48.00	18.09
	-5	-5.6	60.40	22.12	60.20	21.01	56.80	21.18	54.60	20.37	52.40	19.43	48.00	17.57
	-3	-3.7	61.20	22.15	61.00	20.09	56.80	20.13	54.60	19.62	52.40	18.81	48.00	17.12
	0	-0.7	62.40	22.18	61.00	19.08	56.80	19.27	54.60	18.68	52.40	17.89	48.00	16.68
	3	2.2	65.40	22.21	61.00	18.07	56.80	18.18	54.60	17.97	52.40	17.08	48.00	16.11
	5	4.1	65.40	21.66	61.00	17.18	56.80	17.36	54.60	17.05	52.40	16.29	48.00	15.47
7	6	65.40	18.83	61.00	16.87	56.80	16.23	54.60	15.60	52.40	15.00	48.00	13.77	
9	7.9	65.40	17.67	61.00	16.55	56.80	15.42	54.60	14.87	52.40	14.32	48.00	13.24	
11	9.8	65.40	16.65	61.00	15.65	56.80	14.68	54.60	14.19	52.40	13.71	48.00	12.77	
13	11.8	65.40	15.73	61.00	14.87	56.80	14.03	54.60	13.61	52.40	13.19	48.00	12.35	
15	13.7	65.40	15.08	61.00	14.32	56.80	13.56	54.60	13.19	52.40	12.82	48.00	12.06	
80%	-25	-25.4	48.86	22.78	48.66	23.06	48.89	22.36	48.40	21.30	46.60	20.39	42.60	18.49
	-19.8	-20	50.80	21.93	50.60	22.16	50.40	21.41	48.40	20.43	46.60	19.47	42.60	17.58
	-18.8	-19	51.20	21.96	51.00	22.16	50.40	21.21	48.40	20.22	46.60	19.26	42.60	17.40
	-16.7	-17	52.00	21.98	51.80	22.22	50.40	20.77	48.40	19.81	46.60	18.88	42.60	17.04
	-13.7	-15	52.80	22.04	52.60	22.24	50.40	20.35	48.40	19.42	46.60	18.51	42.60	16.73
	-11.8	-13	53.60	22.06	53.40	21.83	50.40	19.94	48.40	19.03	46.60	18.15	42.60	16.42
	-9.8	-11	54.40	22.09	54.20	21.39	50.40	19.58	48.40	18.67	46.60	17.81	42.60	16.11
	-9.5	-10	54.80	22.11	54.20	21.18	50.40	19.37	48.40	18.49	46.60	17.63	42.60	15.95
	-8.5	-9.1	55.20	22.14	54.20	21.00	50.40	19.21	48.40	18.33	46.60	17.48	42.60	15.82
	-7	-7.6	55.80	22.16	54.20	20.69	50.40	18.95	48.40	18.10	46.60	17.24	42.60	15.61
	-5	-5.6	58.20	21.72	54.20	20.02	50.40	18.36	48.40	17.53	46.60	16.75	42.60	15.17
	-3	-3.7	58.20	22.48	54.20	19.29	50.40	17.58	48.40	16.87	46.60	16.14	42.60	14.74
	0	-0.7	58.20	22.19	54.20	18.40	50.40	16.97	48.40	16.37	46.60	15.66	42.60	14.40

3	2.2	58.20	20.51	54.20	17.36	50.40	16.01	48.40	15.79	46.60	15.07	42.60	13.84
5	4.1	58.20	18.75	54.20	16.40	50.40	15.27	48.40	15.15	46.60	14.36	42.60	13.54
7	6	58.20	16.44	54.20	15.35	50.40	14.27	48.40	13.72	46.60	13.21	42.60	12.17
9	7.9	58.20	15.59	54.20	14.63	50.40	13.67	48.40	13.21	46.60	12.71	42.60	11.81
11	9.8	58.20	14.81	54.20	13.96	50.40	13.13	48.40	12.71	46.60	12.30	42.60	11.50
13	11.8	58.20	14.14	54.20	13.39	50.40	12.66	48.40	12.30	46.60	11.94	42.60	11.21
15	13.7	58.20	13.65	54.20	12.97	50.40	12.33	48.40	12.01	46.60	11.68	42.60	11.03

Abbreviations:

CR: Combination ratio

TC: Total capacity (kW)

PI: Power input (compressor + outdoor fan motor) (kW)

Notes: Shaded cells indicate rating condition.

Table 2-8.20: 20HP heating capacity (continued)

CR	Outdoor air temp.		Indoor air temp. °C DB											
			16		18		20		21		22		24	
	°C DB	°C WB	TC kW	PI kW	TC kW	PI kW	TC kW	PI kW	TC kW	PI kW	TC kW	PI kW	TC kW	PI kW
70%	-25	-25.4	50.40	23.05	47.40	21.32	44.20	20.95	42.40	20.57	40.80	20.32	37.40	19.55
	-19.8	-20	50.40	21.95	47.40	20.19	44.20	19.78	42.40	19.40	40.80	19.15	37.40	18.39
	-18.8	-19	50.80	21.71	47.40	19.98	44.20	19.57	42.40	19.19	40.80	18.94	37.40	18.18
	-16.7	-17	50.80	21.27	47.40	19.59	44.20	19.23	42.40	18.85	40.80	18.60	37.40	17.83
	-13.7	-15	50.80	20.85	47.40	19.19	44.20	18.87	42.40	18.48	40.80	18.23	37.40	17.47
	-11.8	-13	50.80	20.43	47.40	18.83	44.20	18.55	42.40	18.17	40.80	17.92	37.40	17.15
	-9.8	-11	50.80	20.03	47.40	18.46	44.20	18.21	42.40	17.83	40.80	17.58	37.40	16.81
	-9.5	-10	50.80	19.85	47.40	18.30	44.20	17.75	42.40	17.37	40.80	17.12	37.40	16.35
	-8.5	-9.1	50.80	19.67	47.40	18.15	44.20	17.16	42.40	16.78	40.80	16.52	37.40	15.76
	-7	-7.6	50.80	19.40	47.40	17.88	44.20	16.41	42.40	16.03	40.80	15.78	37.40	15.02
	-5	-5.6	50.80	18.80	47.40	17.36	44.20	15.97	42.40	15.59	40.80	15.33	37.40	14.57
	-3	-3.7	50.80	17.79	47.40	16.83	44.20	15.50	42.40	15.12	40.80	14.87	37.40	14.10
	0	-0.7	50.80	16.85	47.40	16.10	44.20	14.84	42.40	14.46	40.80	14.21	37.40	13.44
	3	2.2	50.80	15.90	47.40	15.22	44.20	13.94	42.40	13.56	40.80	13.30	37.40	12.54
	5	4.1	50.80	15.17	47.40	14.25	44.20	13.41	42.40	13.03	40.80	12.78	37.40	12.01
60%	7	6	50.80	14.58	47.40	13.64	44.20	12.72	42.40	12.37	40.80	12.12	37.40	11.36
	9	7.9	50.80	13.95	47.40	13.11	44.20	12.30	42.40	11.92	40.80	11.66	37.40	10.90
	11	9.8	50.80	13.40	47.40	12.67	44.20	11.80	42.40	11.42	40.80	11.17	37.40	10.40
	13	11.8	50.80	12.90	47.40	12.14	44.20	11.23	42.40	10.85	40.80	10.60	37.40	9.84
	15	13.7	50.80	12.43	47.40	11.60	44.20	10.80	42.40	10.42	40.80	10.16	37.40	9.40
	-25	-25.4	43.60	21.48	40.80	20.31	37.80	19.37	36.40	18.93	34.80	18.14	32.00	17.19
	-19.8	-20	43.60	20.34	40.80	19.38	37.80	18.64	36.40	18.10	34.80	17.29	32.00	16.30
	-18.8	-19	43.60	19.82	40.80	18.71	37.80	17.98	36.40	17.50	34.80	16.61	32.00	15.72
	-16.7	-17	43.60	19.20	40.80	18.13	37.80	17.42	36.40	16.82	34.80	15.99	32.00	15.09
	-13.7	-15	43.60	18.54	40.80	17.59	37.80	16.88	36.40	16.19	34.80	15.37	32.00	14.46
	-11.8	-13	43.60	17.88	40.80	16.94	37.80	16.23	36.40	15.64	34.80	14.71	32.00	13.82
	-9.8	-11	43.60	17.30	40.80	16.31	37.80	15.45	36.40	14.93	34.80	14.09	32.00	13.31
	-9.5	-10	43.60	16.69	40.80	15.66	37.80	14.82	36.40	14.29	34.80	13.47	32.00	12.59
	-8.5	-9.1	43.60	15.99	40.80	15.09	37.80	14.20	36.40	13.67	34.80	12.84	32.00	11.87
	-7	-7.6	43.60	15.40	40.80	14.45	37.80	13.71	36.40	13.21	34.80	12.35	32.00	11.35
-5	-5.6	43.60	14.83	40.80	13.92	37.80	13.03	36.40	12.66	34.80	11.85	32.00	10.81	
-3	-3.7	43.60	14.31	40.80	13.36	37.80	12.44	36.40	12.16	34.80	11.33	32.00	10.43	
0	-0.7	43.60	13.74	40.80	12.83	37.80	11.89	36.40	11.57	34.80	10.77	32.00	10.23	
50%	3	2.2	43.60	13.11	40.80	12.22	37.80	11.43	36.40	11.10	34.80	10.21	32.00	9.86
	5	4.1	43.60	12.44	40.80	11.70	37.80	11.01	36.40	10.60	34.80	9.98	32.00	9.65
	7	6	43.60	11.87	40.80	11.20	37.80	10.50	36.40	10.17	34.80	9.93	32.00	9.47
	9	7.9	43.60	11.67	40.80	10.95	37.80	10.33	36.40	9.94	34.80	9.51	32.00	9.05
	11	9.8	43.60	11.49	40.80	10.79	37.80	10.06	36.40	9.70	34.80	9.31	32.00	8.88
	13	11.8	43.60	11.13	40.80	10.43	37.80	9.75	36.40	9.49	34.80	9.12	32.00	8.68
	15	13.7	43.60	11.00	40.80	10.22	37.80	9.46	36.40	9.26	34.80	8.88	32.00	8.43
	-25	-25.4	36.40	17.79	34.00	16.82	31.60	16.04	30.20	15.67	29.00	15.28	26.60	14.23
	-19.8	-20	36.40	16.84	34.00	16.04	31.60	15.43	30.20	14.99	29.00	14.57	26.60	13.50
	-18.8	-19	36.40	16.41	34.00	15.49	31.60	14.88	30.20	14.49	29.00	14.01	26.60	13.02
	-16.7	-17	36.40	15.90	34.00	15.01	31.60	14.42	30.20	13.93	29.00	13.50	26.60	12.49
	-13.7	-15	36.40	15.35	34.00	14.56	31.60	13.97	30.20	13.41	29.00	12.98	26.60	11.97
	-11.8	-13	36.40	14.80	34.00	14.02	31.60	13.44	30.20	12.95	29.00	12.44	26.60	11.44
	-9.8	-11	36.40	14.32	34.00	13.50	31.60	12.79	30.20	12.36	29.00	11.92	26.60	11.02
	-9.5	-10	36.40	13.81	34.00	12.96	31.60	12.27	30.20	11.83	29.00	11.41	26.60	10.42
-8.5	-9.1	36.40	13.24	34.00	12.49	31.60	11.76	30.20	11.32	29.00	10.89	26.60	9.83	
-7	-7.6	36.40	12.75	34.00	11.96	31.60	11.35	30.20	10.94	29.00	10.48	26.60	9.40	
-5	-5.6	36.40	12.28	34.00	11.52	31.60	10.78	30.20	10.48	29.00	10.07	26.60	8.95	
-3	-3.7	36.40	11.85	34.00	11.06	31.60	10.30	30.20	10.07	29.00	9.64	26.60	8.63	
0	-0.7	36.40	11.37	34.00	10.63	31.60	9.84	30.20	9.58	29.00	9.17	26.60	8.47	

MDV6 VRF 50Hz



	3	2.2	36.40	10.85	34.00	10.12	31.60	9.47	30.20	9.19	29.00	8.72	26.60	8.42
	5	4.1	36.40	10.30	34.00	9.68	31.60	9.12	30.20	8.78	29.00	8.53	26.60	8.34
	7	6	36.40	9.83	34.00	9.27	31.60	8.69	30.20	8.42	29.00	8.39	26.60	8.10
	9	7.9	36.40	9.66	34.00	9.06	31.60	8.55	30.20	8.23	29.00	8.05	26.60	7.84
	11	9.8	36.40	9.51	34.00	8.93	31.60	8.33	30.20	8.03	29.00	7.90	26.60	7.70
	13	11.8	36.40	9.22	34.00	8.63	31.60	8.07	30.20	7.85	29.00	7.72	26.60	7.53
	15	13.7	36.40	9.11	34.00	8.46	31.60	7.84	30.20	7.67	29.00	7.51	26.60	7.33

Abbreviations:

CR: Combination ratio

TC: Total capacity (kW)

PI: Power input (compressor + outdoor fan motor) (kW)

Notes:

Shaded cells indicate rating condition.

Table 2-8.21: 22HP heating capacity

CR	Outdoor air temp.		Indoor air temp. °C DB											
			16		18		20		21		22		24	
	°C DB	°C WB	TC kW	PI kW	TC kW	PI kW	TC kW	PI kW	TC kW	PI kW	TC kW	PI kW	TC kW	PI kW
130%	-25	-25.4	51.64	18.54	51.43	18.86	50.36	19.61	50.19	20.17	50.15	20.72	49.86	21.05
	-19.8	-20	54.28	19.03	54.07	19.44	53.86	20.42	53.65	20.97	53.65	21.52	53.44	21.80
	-18.8	-19	54.70	19.37	54.49	19.69	54.28	20.60	54.28	21.16	54.07	21.71	53.86	21.91
	-16.7	-17	55.53	19.59	55.32	20.04	55.12	20.83	55.12	21.38	54.91	21.94	54.70	22.29
	-13.7	-15	56.37	19.82	56.16	20.34	55.95	21.20	55.95	21.75	55.74	22.30	55.53	22.60
	-11.8	-13	57.21	20.16	57.00	20.67	56.79	21.59	56.79	22.14	56.58	22.70	56.58	22.94
	-9.8	-11	58.05	20.46	57.84	21.04	57.63	21.81	57.63	22.37	57.63	22.92	57.42	22.97
	-9.5	-10	58.47	20.77	58.26	21.25	58.26	22.15	58.05	22.71	58.05	23.26	57.84	23.32
	-8.5	-9.1	58.89	21.05	58.68	21.56	58.47	22.39	58.47	22.95	58.47	23.50	58.26	23.58
	-7	-7.6	59.52	21.08	59.31	21.86	59.31	22.60	59.10	23.13	59.10	23.84	58.89	23.89
	-5	-5.6	64.13	22.00	63.92	22.47	63.71	23.31	63.71	24.01	63.50	23.99	63.29	24.18
	-3	-3.7	64.96	22.53	64.76	22.84	64.55	23.69	64.55	24.40	64.34	24.30	64.13	24.49
	0	-0.7	66.22	23.19	66.01	23.06	65.80	23.99	65.80	24.65	65.59	24.67	65.59	24.68
	3	2.2	73.16	24.52	72.30	24.55	72.09	25.24	71.88	25.71	71.88	25.97	71.67	26.18
	5	4.1	90.95	29.62	87.30	29.28	85.92	29.16	82.57	28.23	79.22	27.91	72.72	26.70
120%	7	6	92.42	29.86	88.98	28.49	85.92	27.73	82.57	27.02	79.22	26.76	72.72	25.78
	9	7.9	92.42	28.40	88.98	27.13	85.92	26.89	82.57	26.52	79.22	26.08	72.72	25.19
	11	9.8	92.42	27.03	88.98	26.02	85.92	25.97	82.57	25.63	79.22	25.31	72.72	24.22
	13	11.8	92.42	25.71	88.98	25.25	85.92	25.24	82.57	25.20	79.22	24.75	72.72	23.79
	15	13.7	92.42	24.91	88.98	24.68	85.92	24.54	82.57	24.20	79.22	24.04	72.72	22.91
	-25	-25.4	51.13	20.20	50.92	20.94	50.88	21.67	50.71	22.20	50.49	22.72	50.33	23.05
	-19.8	-20	54.22	20.75	54.01	21.45	53.80	22.07	53.80	22.59	53.59	23.11	53.38	23.51
	-18.8	-19	54.64	21.04	54.43	21.48	54.22	22.44	54.22	22.97	54.01	23.49	53.80	23.77
	-16.7	-17	55.48	21.36	55.27	21.79	55.06	22.75	55.06	23.27	54.85	23.79	54.85	23.86
	-13.7	-15	56.32	21.63	56.11	22.23	55.90	22.86	55.90	23.38	55.90	23.90	55.69	24.10
	-11.8	-13	57.16	21.95	56.95	22.47	56.83	23.15	56.74	23.68	56.74	24.20	56.53	24.37
	-9.8	-11	58.00	22.07	57.79	22.62	57.79	23.41	57.58	23.94	57.58	24.46	57.37	24.82
	-9.5	-10	58.42	22.33	58.21	22.79	58.21	23.58	58.00	24.10	58.00	24.62	57.79	25.13
	-8.5	-9.1	58.84	22.54	58.63	23.08	58.63	23.84	58.42	24.37	58.42	24.89	58.21	25.16
	-7	-7.6	59.47	22.95	59.26	23.50	59.26	24.11	59.05	24.63	59.05	25.15	58.84	25.45
-5	-5.6	64.09	23.13	63.88	23.68	63.67	24.36	63.67	24.88	63.67	25.40	63.46	25.88	
-3	-3.7	64.93	23.54	64.72	24.07	64.51	24.67	64.51	25.20	64.30	25.72	64.30	26.01	
0	-0.7	66.20	23.83	65.98	24.41	65.77	24.88	65.77	25.41	65.77	25.93	65.56	26.19	
3	2.2	72.29	25.28	72.29	25.95	72.08	26.15	71.87	26.68	71.87	27.20	67.25	25.93	
5	4.1	90.99	28.33	85.53	28.05	79.43	27.59	76.28	27.03	73.34	26.74	67.25	25.14	
7	6	91.62	28.13	85.53	26.87	79.43	26.19	76.28	25.73	73.34	25.58	67.25	24.53	
9	7.9	91.62	26.91	85.53	25.67	79.43	25.39	76.28	24.88	73.34	24.84	67.25	23.78	
11	9.8	91.62	26.03	85.53	25.13	79.43	24.52	76.28	24.15	73.34	23.95	67.25	22.90	
13	11.8	91.62	25.41	85.53	24.49	79.43	23.84	76.28	23.78	73.34	23.51	67.25	22.45	
15	13.7	91.62	24.85	85.53	23.77	79.43	23.18	76.28	22.90	73.34	22.71	67.25	21.62	
110%	-25	-25.4	51.77	20.80	51.53	21.28	51.27	21.76	51.35	21.43	51.16	21.85	51.14	22.41
	-19.8	-20	54.01	21.09	53.80	21.58	53.59	22.06	53.59	21.73	53.38	22.13	53.38	22.69
	-18.8	-19	54.43	21.41	54.22	21.89	54.01	22.38	54.01	21.76	53.80	22.38	53.80	22.76
	-16.7	-17	55.27	21.72	55.06	22.20	54.85	22.69	54.85	22.18	54.85	22.65	54.64	23.06
	-13.7	-15	56.11	21.91	55.90	22.40	55.69	22.88	55.69	22.31	55.69	22.75	55.48	23.30
	-11.8	-13	56.95	22.24	56.74	22.72	56.74	23.20	56.53	22.54	56.53	23.02	56.32	23.58
	-9.8	-11	57.79	22.24	57.58	22.72	57.58	23.21	57.37	22.96	57.37	23.29	57.16	23.88
	-9.5	-10	58.21	22.49	58.21	22.97	58.00	23.45	57.79	23.04	57.79	23.57	57.58	24.12
	-8.5	-9.1	58.63	22.73	58.42	23.21	58.42	23.70	58.21	23.25	58.21	23.81	58.00	24.40
	-7	-7.6	59.26	22.97	59.05	23.46	59.05	23.94	58.84	23.59	58.84	24.08	58.63	24.46
-5	-5.6	63.88	23.28	63.67	23.76	63.46	24.25	63.46	23.82	63.46	24.22	61.57	24.20	
-3	-3.7	64.72	23.45	64.51	23.93	64.30	24.42	64.30	24.03	64.30	24.53	61.57	23.79	

	0	-0.7	65.98	24.01	65.77	24.50	65.77	24.98	65.56	24.22	65.56	24.75	61.57	23.45
	3	2.2	72.08	25.09	72.08	25.57	71.87	26.05	69.98	25.19	67.25	24.94	61.57	23.25
	5	4.1	84.06	27.38	78.38	27.30	72.92	25.46	69.98	24.74	67.25	24.31	61.57	23.16
	7	6	84.06	26.37	78.38	25.72	72.92	24.17	69.98	23.53	67.25	23.18	61.57	22.58
	9	7.9	84.06	25.17	78.38	24.33	72.92	23.31	69.98	22.94	67.25	22.69	61.57	22.19
	11	9.8	84.06	24.27	78.38	23.44	72.92	22.65	69.98	22.11	67.25	21.95	61.57	21.45
	13	11.8	84.06	23.56	78.38	22.71	72.92	21.92	69.98	21.47	67.25	21.20	61.57	20.72
	15	13.7	84.06	22.88	78.38	21.96	72.92	21.19	69.98	20.73	67.25	20.48	61.57	19.99

Abbreviations:

CR: Combination ratio

TC: Total capacity (kW)

PI: Power input (compressor + outdoor fan motor) (kW)

Notes:

Shaded cells indicate rating condition.

Table 2-8.21: 22HP heating capacity (continued)

CR	Outdoor air temp.		Indoor air temp. °C DB											
			16		18		20		21		22		24	
	°C DB	°C WB	TC kW	PI kW	TC kW	PI kW	TC kW	PI kW	TC kW	PI kW	TC kW	PI kW	TC kW	PI kW
100%	-25	-25.4	51.81	25.98	51.60	26.23	51.39	26.39	51.39	26.68	51.39	26.83	51.18	27.18
	-19.8	-20	54.22	25.98	54.01	26.26	53.80	26.55	53.80	26.71	53.80	26.87	53.59	26.99
	-18.8	-19	55.06	26.04	54.85	26.33	54.64	26.61	54.64	26.74	54.64	26.90	54.43	26.78
	-16.7	-17	55.90	26.07	55.69	26.36	55.69	26.64	55.48	26.80	55.48	26.96	55.27	26.64
	-13.7	-15	56.74	26.14	56.53	26.39	56.53	26.71	56.32	26.83	56.32	26.99	56.11	26.32
	-11.8	-13	57.58	26.17	57.37	26.45	57.37	26.74	57.16	26.90	57.16	27.02	56.11	26.04
	-9.8	-11	58.00	26.20	58.00	26.49	57.79	26.77	57.79	26.90	57.58	27.06	56.11	26.00
	-9.5	-10	58.42	26.23	58.21	26.49	58.21	26.84	58.00	26.93	58.00	27.09	56.11	25.78
	-8.5	-9.1	59.05	26.26	59.05	26.52	58.84	26.92	58.63	26.96	58.63	27.12	56.11	25.39
	-7	-7.6	63.67	26.30	63.46	26.53	63.46	27.47	63.25	27.94	61.15	26.58	56.11	25.29
	-5	-5.6	64.51	26.33	64.30	26.54	64.30	26.83	63.67	27.15	61.15	25.79	56.11	24.59
	-3	-3.7	65.77	26.36	65.56	26.56	65.56	25.95	63.67	25.58	61.15	24.97	56.11	23.77
	0	-0.7	67.46	26.39	71.24	26.58	66.20	25.22	63.67	24.42	61.15	23.75	56.11	22.74
	3	2.2	71.87	25.86	71.24	25.92	66.20	24.50	63.67	23.24	61.15	22.33	56.11	21.62
	5	4.1	76.28	25.45	71.24	24.65	66.20	23.34	63.67	22.19	61.15	21.42	56.11	20.66
	7	6	76.28	25.13	71.24	23.38	66.20	21.86	63.67	21.00	61.15	20.55	56.11	19.75
9	7.9	76.28	23.70	71.24	22.15	66.20	21.25	63.67	20.49	61.15	19.95	56.11	19.11	
11	9.8	76.28	22.18	71.24	20.78	66.20	20.55	63.67	19.66	61.15	19.21	56.11	18.31	
13	11.8	76.28	20.78	71.24	20.27	66.20	19.75	63.67	18.96	61.15	18.54	56.11	17.69	
15	13.7	76.28	19.77	71.24	19.41	66.20	19.02	63.67	18.30	61.15	17.87	56.11	16.99	
90%	-25	-25.4	51.41	25.95	51.13	26.20	50.96	26.49	50.92	26.84	50.92	26.93	50.43	25.24
	-19.8	-20	53.59	26.39	53.38	26.64	53.17	26.93	53.17	27.09	53.17	27.25	50.43	24.71
	-18.8	-19	54.01	26.42	53.80	26.68	53.59	26.96	53.59	27.12	53.59	27.15	50.43	24.46
	-16.7	-17	54.85	26.45	54.64	26.71	54.64	26.99	54.43	27.15	54.43	26.61	50.43	23.95
	-13.7	-15	55.69	26.49	55.48	26.77	55.48	27.06	55.27	27.18	55.06	26.07	50.43	23.48
	-11.8	-13	56.53	26.55	56.32	26.80	56.32	27.09	56.11	26.83	55.06	25.54	50.43	23.03
	-9.8	-11	57.37	26.58	57.37	26.87	57.16	27.12	57.16	26.30	55.06	25.06	50.43	22.59
	-9.5	-10	57.79	26.61	57.79	26.87	57.58	27.15	57.37	26.04	55.06	24.81	50.43	22.37
	-8.5	-9.1	58.21	26.64	58.00	26.90	58.00	27.09	57.37	25.82	55.06	24.58	50.43	22.18
	-7	-7.6	58.84	26.68	58.84	26.54	58.63	26.71	57.37	25.47	55.06	24.24	50.43	21.86
	-5	-5.6	63.46	26.72	63.25	25.39	59.68	25.59	57.37	24.62	55.06	23.48	50.43	21.23
	-3	-3.7	64.30	26.76	64.09	24.27	59.68	24.32	57.37	23.71	55.06	22.73	50.43	20.68
	0	-0.7	65.56	26.80	64.09	23.05	59.68	23.28	57.37	22.57	55.06	21.61	50.43	20.15
	3	2.2	68.72	26.83	64.09	21.84	59.68	21.97	57.37	21.72	55.06	20.64	50.43	19.47
	5	4.1	68.72	26.17	64.09	20.76	59.68	20.97	57.37	20.60	55.06	19.68	50.43	18.69
	7	6	68.72	22.75	64.09	20.38	59.68	19.61	57.37	18.85	55.06	18.12	50.43	16.63
9	7.9	68.72	21.35	64.09	19.99	59.68	18.63	57.37	17.96	55.06	17.30	50.43	16.00	
11	9.8	68.72	20.12	64.09	18.91	59.68	17.74	57.37	17.14	55.06	16.57	50.43	15.43	
13	11.8	68.72	19.01	64.09	17.96	59.68	16.95	57.37	16.44	55.06	15.94	50.43	14.92	
15	13.7	68.72	18.22	64.09	17.30	59.68	16.38	57.37	15.94	55.06	15.49	50.43	14.57	
80%	-25	-25.4	51.34	27.52	51.13	27.86	51.37	27.02	50.85	25.74	48.96	24.64	44.76	22.34
	-19.8	-20	53.38	26.50	53.17	26.78	52.96	25.87	50.85	24.68	48.96	23.53	44.76	21.24
	-18.8	-19	53.80	26.53	53.59	26.78	52.96	25.62	50.85	24.43	48.96	23.28	44.76	21.02
	-16.7	-17	54.64	26.56	54.43	26.84	52.96	25.09	50.85	23.93	48.96	22.81	44.76	20.59
	-13.7	-15	55.48	26.62	55.27	26.87	52.96	24.59	50.85	23.46	48.96	22.37	44.76	20.21
	-11.8	-13	56.32	26.65	56.11	26.37	52.96	24.09	50.85	22.99	48.96	21.93	44.76	19.83
	-9.8	-11	57.16	26.69	56.95	25.84	52.96	23.65	50.85	22.56	48.96	21.52	44.76	19.46
	-9.5	-10	57.58	26.72	56.95	25.59	52.96	23.40	50.85	22.34	48.96	21.30	44.76	19.27
	-8.5	-9.1	58.00	26.75	56.95	25.37	52.96	23.21	50.85	22.15	48.96	21.12	44.76	19.12
	-7	-7.6	58.63	26.78	56.95	25.00	52.96	22.90	50.85	21.87	48.96	20.84	44.76	18.86
-5	-5.6	61.15	26.25	56.95	24.18	52.96	22.18	50.85	21.18	48.96	20.24	44.76	18.33	

MDV6 VRF 50Hz



	-3	-3.7	61.15	27.16	56.95	23.30	52.96	21.24	50.85	20.38	48.96	19.51	44.76	17.81
	0	-0.7	61.15	26.81	56.95	22.23	52.96	20.50	50.85	19.78	48.96	18.92	44.76	17.40
	3	2.2	61.15	24.78	56.95	20.97	52.96	19.34	50.85	19.08	48.96	18.21	44.76	16.72
	5	4.1	61.15	22.65	56.95	19.82	52.96	18.45	50.85	18.30	48.96	17.35	44.76	16.36
	7	6	61.15	19.87	56.95	18.55	52.96	17.24	50.85	16.58	48.96	15.96	44.76	14.70
	9	7.9	61.15	18.83	56.95	17.68	52.96	16.52	50.85	15.96	48.96	15.36	44.76	14.27
	11	9.8	61.15	17.89	56.95	16.86	52.96	15.86	50.85	15.36	48.96	14.86	44.76	13.89
	13	11.8	61.15	17.08	56.95	16.17	52.96	15.30	50.85	14.86	48.96	14.42	44.76	13.55
	15	13.7	61.15	16.49	56.95	15.67	52.96	14.89	50.85	14.52	48.96	14.11	44.76	13.33

Abbreviations:

CR: Combination ratio

TC: Total capacity (kW)

PI: Power input (compressor + outdoor fan motor) (kW)

Notes: Shaded cells indicate rating condition.

Table 2-8.21: 22HP heating capacity (continued)

CR	Outdoor air temp.		Indoor air temp. °C DB											
			16		18		20		21		22		24	
	°C DB	°C WB	TC kW	PI kW	TC kW	PI kW	TC kW	PI kW	TC kW	PI kW	TC kW	PI kW	TC kW	PI kW
70%	-25	-25.4	52.96	27.85	49.80	25.76	46.44	25.31	44.55	24.85	42.87	24.55	39.30	23.62
	-19.8	-20	52.96	26.52	49.80	24.39	46.44	23.90	44.55	23.44	42.87	23.14	39.30	22.21
	-18.8	-19	53.38	26.23	49.80	24.14	46.44	23.65	44.55	23.19	42.87	22.88	39.30	21.96
	-16.7	-17	53.38	25.69	49.80	23.67	46.44	23.24	44.55	22.78	42.87	22.47	39.30	21.55
	-13.7	-15	53.38	25.19	49.80	23.19	46.44	22.79	44.55	22.33	42.87	22.03	39.30	21.10
	-11.8	-13	53.38	24.68	49.80	22.75	46.44	22.41	44.55	21.95	42.87	21.65	39.30	20.72
	-9.8	-11	53.38	24.20	49.80	22.30	46.44	22.00	44.55	21.54	42.87	21.23	39.30	20.31
	-9.5	-10	53.38	23.98	49.80	22.11	46.44	21.45	44.55	20.99	42.87	20.68	39.30	19.76
	-8.5	-9.1	53.38	23.76	49.80	21.92	46.44	20.73	44.55	20.27	42.87	19.96	39.30	19.04
	-7	-7.6	53.38	23.44	49.80	21.61	46.44	19.83	44.55	19.37	42.87	19.06	39.30	18.14
	-5	-5.6	53.38	22.72	49.80	20.97	46.44	19.29	44.55	18.83	42.87	18.53	39.30	17.60
	-3	-3.7	53.38	21.50	49.80	20.34	46.44	18.73	44.55	18.27	42.87	17.96	39.30	17.04
	0	-0.7	53.38	20.36	49.80	19.45	46.44	17.93	44.55	17.47	42.87	17.16	39.30	16.24
	3	2.2	53.38	19.21	49.80	18.39	46.44	16.84	44.55	16.38	42.87	16.07	39.30	15.15
	5	4.1	53.38	18.33	49.80	17.22	46.44	16.21	44.55	15.74	42.87	15.44	39.30	14.51
7	6	53.38	17.61	49.80	16.47	46.44	15.37	44.55	14.95	42.87	14.64	39.30	13.72	
9	7.9	53.38	16.85	49.80	15.84	46.44	14.86	44.55	14.40	42.87	14.09	39.30	13.17	
11	9.8	53.38	16.19	49.80	15.30	46.44	14.26	44.55	13.80	42.87	13.49	39.30	12.57	
13	11.8	53.38	15.59	49.80	14.67	46.44	13.57	44.55	13.11	42.87	12.81	39.30	11.88	
15	13.7	53.38	15.02	49.80	14.02	46.44	13.04	44.55	12.58	42.87	12.28	39.30	11.35	
60%	-25	-25.4	45.81	25.96	42.87	24.54	39.72	23.40	38.25	22.87	36.56	21.91	33.62	20.77
	-19.8	-20	45.81	24.58	42.87	23.41	39.72	22.52	38.25	21.87	36.56	20.89	33.62	19.70
	-18.8	-19	45.81	23.95	42.87	22.61	39.72	21.72	38.25	21.14	36.56	20.07	33.62	18.99
	-16.7	-17	45.81	23.20	42.87	21.91	39.72	21.05	38.25	20.33	36.56	19.32	33.62	18.24
	-13.7	-15	45.81	22.40	42.87	21.25	39.72	20.39	38.25	19.57	36.56	18.56	33.62	17.48
	-11.8	-13	45.81	21.60	42.87	20.46	39.72	19.61	38.25	18.90	36.56	17.77	33.62	16.70
	-9.8	-11	45.81	20.91	42.87	19.71	39.72	18.67	38.25	18.03	36.56	17.02	33.62	16.08
	-9.5	-10	45.81	20.16	42.87	18.92	39.72	17.91	38.25	17.26	36.56	16.28	33.62	15.21
	-8.5	-9.1	45.81	19.32	42.87	18.23	39.72	17.16	38.25	16.52	36.56	15.52	33.62	14.34
	-7	-7.6	45.81	18.60	42.87	17.46	39.72	16.56	38.25	15.96	36.56	14.92	33.62	13.71
	-5	-5.6	45.81	17.91	42.87	16.81	39.72	15.74	38.25	15.30	36.56	14.32	33.62	13.06
	-3	-3.7	45.81	17.29	42.87	16.15	39.72	15.04	38.25	14.69	36.56	13.69	33.62	12.60
	0	-0.7	45.81	16.60	42.87	15.51	39.72	14.36	38.25	13.98	36.56	13.01	33.62	12.36
	3	2.2	45.81	15.84	42.87	14.76	39.72	13.81	38.25	13.41	36.56	12.34	33.62	11.91
	5	4.1	45.81	15.03	42.87	14.13	39.72	13.31	38.25	12.81	36.56	12.06	33.62	11.66
7	6	45.81	14.34	42.87	13.53	39.72	12.68	38.25	12.29	36.56	12.00	33.62	11.44	
9	7.9	45.81	14.10	42.87	13.23	39.72	12.48	38.25	12.00	36.56	11.49	33.62	10.93	
11	9.8	45.81	13.88	42.87	13.04	39.72	12.16	38.25	11.72	36.56	11.25	33.62	10.73	
13	11.8	45.81	13.45	42.87	12.60	39.72	11.78	38.25	11.46	36.56	11.02	33.62	10.49	
15	13.7	45.81	13.29	42.87	12.35	39.72	11.43	38.25	11.19	36.56	10.73	33.62	10.19	
50%	-25	-25.4	38.25	21.49	35.72	20.32	33.20	19.37	31.73	18.93	30.47	18.46	27.95	17.20
	-19.8	-20	38.25	20.35	35.72	19.38	33.20	18.64	31.73	18.11	30.47	17.61	27.95	16.31
	-18.8	-19	38.25	19.83	35.72	18.71	33.20	17.98	31.73	17.50	30.47	16.93	27.95	15.73
	-16.7	-17	38.25	19.21	35.72	18.14	33.20	17.43	31.73	16.83	30.47	16.31	27.95	15.10
	-13.7	-15	38.25	18.54	35.72	17.59	33.20	16.88	31.73	16.20	30.47	15.68	27.95	14.47
	-11.8	-13	38.25	17.89	35.72	16.94	33.20	16.23	31.73	15.64	30.47	15.03	27.95	13.82
	-9.8	-11	38.25	17.31	35.72	16.31	33.20	15.46	31.73	14.93	30.47	14.41	27.95	13.32
	-9.5	-10	38.25	16.69	35.72	15.66	33.20	14.82	31.73	14.29	30.47	13.79	27.95	12.59
	-8.5	-9.1	38.25	15.99	35.72	15.10	33.20	14.20	31.73	13.68	30.47	13.16	27.95	11.87
	-7	-7.6	38.25	15.40	35.72	14.45	33.20	13.71	31.73	13.22	30.47	12.66	27.95	11.35
-5	-5.6	38.25	14.83	35.72	13.92	33.20	13.03	31.73	12.67	30.47	12.17	27.95	10.81	

-3	-3.7	38.25	14.31	35.72	13.37	33.20	12.45	31.73	12.16	30.47	11.65	27.95	10.43
0	-0.7	38.25	13.74	35.72	12.84	33.20	11.89	31.73	11.57	30.47	11.08	27.95	10.23
3	2.2	38.25	13.11	35.72	12.22	33.20	11.44	31.73	11.10	30.47	10.53	27.95	10.18
5	4.1	38.25	12.44	35.72	11.70	33.20	11.02	31.73	10.61	30.47	10.30	27.95	10.07
7	6	38.25	11.87	35.72	11.20	33.20	10.50	31.73	10.18	30.47	10.14	27.95	9.78
9	7.9	38.25	11.67	35.72	10.95	33.20	10.34	31.73	9.94	30.47	9.72	27.95	9.47
11	9.8	38.25	11.49	35.72	10.79	33.20	10.07	31.73	9.70	30.47	9.54	27.95	9.30
13	11.8	38.25	11.14	35.72	10.43	33.20	9.75	31.73	9.49	30.47	9.33	27.95	9.10
15	13.7	38.25	11.00	35.72	10.22	33.20	9.47	31.73	9.26	30.47	9.08	27.95	8.86

Abbreviations:

CR: Combination ratio

TC: Total capacity (kW)

PI: Power input (compressor + outdoor fan motor) (kW)

Notes:

Shaded cells indicate rating condition.

Table 2-8.22: 24HP heating capacity

CR	Outdoor air temp.		Indoor air temp. °C DB											
			16		18		20		21		22		24	
	°C DB	°C WB	TC kW	PI kW	TC kW	PI kW	TC kW	PI kW	TC kW	PI kW	TC kW	PI kW	TC kW	PI kW
130%	-25	-25.4	58.50	17.76	58.27	18.07	57.06	18.78	56.87	19.32	56.82	19.85	56.49	20.16
	-19.8	-20	61.50	18.23	61.26	18.62	61.02	19.56	60.78	20.09	60.78	20.62	60.55	20.88
	-18.8	-19	61.97	18.56	61.73	18.86	61.50	19.74	61.50	20.27	61.26	20.80	61.02	20.99
	-16.7	-17	62.92	18.76	62.68	19.20	62.45	19.95	62.45	20.48	62.21	21.01	61.97	21.35
	-13.7	-15	63.87	18.98	63.63	19.49	63.40	20.30	63.40	20.83	63.16	21.36	62.92	21.65
	-11.8	-13	64.82	19.31	64.58	19.80	64.35	20.68	64.35	21.21	64.11	21.74	64.11	21.97
	-9.8	-11	65.77	19.60	65.53	20.15	65.30	20.90	65.30	21.43	65.30	21.96	65.06	22.00
	-9.5	-10	66.25	19.90	66.01	20.36	66.01	21.22	65.77	21.75	65.77	22.28	65.53	22.34
	-8.5	-9.1	66.72	20.16	66.48	20.65	66.25	21.45	66.25	21.98	66.25	22.51	66.01	22.59
	-7	-7.6	67.43	20.19	67.20	20.94	67.20	21.65	66.96	22.16	66.96	22.83	66.72	22.89
	-5	-5.6	72.66	21.07	72.42	21.52	72.18	22.33	72.18	23.00	71.94	22.98	71.71	23.16
	-3	-3.7	73.61	21.58	73.37	21.87	73.13	22.69	73.13	23.37	72.89	23.28	72.66	23.45
	0	-0.7	75.03	22.21	74.79	22.09	74.56	22.98	74.56	23.62	74.32	23.63	74.32	23.64
	3	2.2	82.89	23.49	81.92	23.51	81.68	24.17	81.44	24.62	81.44	24.87	81.20	25.08
	5	4.1	103.05	28.37	98.92	28.04	97.35	27.93	93.55	27.04	89.75	26.74	82.39	25.58
7	6	104.71	28.60	100.82	27.29	97.35	26.56	93.55	25.88	89.75	25.63	82.39	24.70	
9	7.9	104.71	27.21	100.82	25.98	97.35	25.75	93.55	25.40	89.75	24.98	82.39	24.13	
11	9.8	104.71	25.89	100.82	24.92	97.35	24.87	93.55	24.55	89.75	24.24	82.39	23.20	
13	11.8	104.71	24.63	100.82	24.18	97.35	24.18	93.55	24.13	89.75	23.71	82.39	22.78	
15	13.7	104.71	23.86	100.82	23.64	97.35	23.51	93.55	23.18	89.75	23.03	82.39	21.94	
120%	-25	-25.4	57.93	19.35	57.70	20.06	57.65	20.76	57.46	21.26	57.20	21.76	57.03	22.08
	-19.8	-20	61.43	19.88	61.19	20.54	60.95	21.14	60.95	21.64	60.71	22.14	60.48	22.52
	-18.8	-19	61.90	20.16	61.67	20.57	61.43	21.50	61.43	22.00	61.19	22.50	60.95	22.77
	-16.7	-17	62.86	20.46	62.62	20.87	62.38	21.79	62.38	22.29	62.14	22.79	62.14	22.85
	-13.7	-15	63.81	20.72	63.57	21.29	63.33	21.89	63.33	22.39	63.33	22.90	63.10	23.08
	-11.8	-13	64.76	21.03	64.52	21.52	64.39	22.18	64.29	22.68	64.29	23.18	64.05	23.34
	-9.8	-11	65.71	21.14	65.48	21.67	65.48	22.43	65.24	22.93	65.24	23.43	65.00	23.78
	-9.5	-10	66.19	21.39	65.95	21.83	65.95	22.58	65.71	23.08	65.71	23.59	65.48	24.07
	-8.5	-9.1	66.67	21.59	66.43	22.11	66.43	22.84	66.19	23.34	66.19	23.84	65.95	24.10
	-7	-7.6	67.38	21.98	67.14	22.51	67.14	23.09	66.90	23.59	66.90	24.09	66.67	24.37
	-5	-5.6	72.62	22.16	72.38	22.69	72.14	23.33	72.14	23.83	72.14	24.33	71.90	24.79
	-3	-3.7	73.57	22.55	73.33	23.06	73.10	23.63	73.10	24.13	72.86	24.64	72.86	24.91
	0	-0.7	75.00	22.83	74.76	23.38	74.52	23.83	74.52	24.33	74.52	24.84	74.29	25.09
	3	2.2	81.90	24.22	81.90	24.85	81.67	25.05	81.43	25.55	81.43	26.05	76.19	24.84
	5	4.1	103.10	27.14	96.90	26.86	90.00	26.42	86.43	25.89	83.10	25.61	76.19	24.08
7	6	103.81	26.95	96.90	25.74	90.00	25.09	86.43	24.64	83.10	24.50	76.19	23.49	
9	7.9	103.81	25.78	96.90	24.59	90.00	24.32	86.43	23.84	83.10	23.80	76.19	22.78	
11	9.8	103.81	24.94	96.90	24.07	90.00	23.49	86.43	23.13	83.10	22.94	76.19	21.93	
13	11.8	103.81	24.34	96.90	23.46	90.00	22.84	86.43	22.77	83.10	22.52	76.19	21.50	
15	13.7	103.81	23.80	96.90	22.76	90.00	22.20	86.43	21.94	83.10	21.76	76.19	20.71	
110%	-25	-25.4	58.65	19.92	58.38	20.38	58.09	20.85	58.18	20.53	57.96	20.92	57.94	21.47
	-19.8	-20	61.19	20.20	60.95	20.67	60.71	21.13	60.71	20.81	60.48	21.20	60.48	21.74
	-18.8	-19	61.67	20.51	61.43	20.97	61.19	21.43	61.19	20.84	60.95	21.43	60.95	21.81
	-16.7	-17	62.62	20.80	62.38	21.27	62.14	21.73	62.14	21.24	62.14	21.69	61.90	22.09
	-13.7	-15	63.57	20.99	63.33	21.45	63.10	21.92	63.10	21.37	63.10	21.79	62.86	22.32
	-11.8	-13	64.52	21.30	64.29	21.76	64.29	22.23	64.05	21.59	64.05	22.05	63.81	22.58
	-9.8	-11	65.48	21.30	65.24	21.77	65.24	22.23	65.00	21.99	65.00	22.31	64.76	22.88
	-9.5	-10	65.95	21.54	65.95	22.00	65.71	22.46	65.48	22.07	65.48	22.57	65.24	23.11
	-8.5	-9.1	66.43	21.77	66.19	22.24	66.19	22.70	65.95	22.27	65.95	22.80	65.71	23.37
	-7	-7.6	67.14	22.01	66.90	22.47	66.90	22.93	66.67	22.60	66.67	23.07	66.43	23.43
	-5	-5.6	72.38	22.30	72.14	22.76	71.90	23.22	71.90	22.82	71.90	23.20	69.76	23.18
	-3	-3.7	73.33	22.46	73.10	22.92	72.86	23.39	72.86	23.01	72.86	23.50	69.76	22.79
0	-0.7	74.76	23.00	74.52	23.47	74.52	23.93	74.29	23.20	74.29	23.71	69.76	22.46	

	3	2.2	81.67	24.03	81.67	24.49	81.43	24.96	79.29	24.13	76.19	23.89	69.76	22.27
	5	4.1	95.24	26.23	88.81	26.15	82.62	24.39	79.29	23.70	76.19	23.28	69.76	22.18
	7	6	95.24	25.25	88.81	24.63	82.62	23.15	79.29	22.54	76.19	22.20	69.76	21.63
	9	7.9	95.24	24.11	88.81	23.31	82.62	22.33	79.29	21.97	76.19	21.73	69.76	21.25
	11	9.8	95.24	23.25	88.81	22.45	82.62	21.69	79.29	21.18	76.19	21.03	69.76	20.55
	13	11.8	95.24	22.56	88.81	21.75	82.62	21.00	79.29	20.56	76.19	20.31	69.76	19.85
	15	13.7	95.24	21.92	88.81	21.03	82.62	20.30	79.29	19.86	76.19	19.62	69.76	19.15

Abbreviations:

CR: Combination ratio

TC: Total capacity (kW)

PI: Power input (compressor + outdoor fan motor) (kW)

Notes: Shaded cells indicate rating condition.

Table 2-8.22: 24HP heating capacity (continued)

CR	Outdoor air temp.		Indoor air temp. °C DB											
			16		18		20		21		22		24	
	°C DB	°C WB	TC kW	PI kW	TC kW	PI kW	TC kW	PI kW	TC kW	PI kW	TC kW	PI kW	TC kW	PI kW
100%	-25	-25.4	58.70	24.88	58.46	25.13	58.23	25.27	58.23	25.55	58.23	25.70	57.99	26.04
	-19.8	-20	61.43	24.88	61.19	25.16	60.95	25.43	60.95	25.58	60.95	25.73	60.71	25.86
	-18.8	-19	62.38	24.94	62.14	25.22	61.90	25.49	61.90	25.61	61.90	25.76	61.67	25.65
	-16.7	-17	63.33	24.98	63.10	25.25	63.10	25.52	62.86	25.67	62.86	25.82	62.62	25.52
	-13.7	-15	64.29	25.04	64.05	25.28	64.05	25.58	63.81	25.70	63.81	25.86	63.57	25.21
	-11.8	-13	65.24	25.07	65.00	25.34	65.00	25.61	64.76	25.76	64.76	25.89	63.57	24.94
	-9.8	-11	65.71	25.10	65.71	25.37	65.48	25.64	65.48	25.76	65.24	25.92	63.57	24.91
	-9.5	-10	66.19	25.13	65.95	25.37	65.95	25.71	65.71	25.79	65.71	25.95	63.57	24.69
	-8.5	-9.1	66.90	25.16	66.90	25.40	66.67	25.79	66.43	25.82	66.43	25.98	63.57	24.32
	-7	-7.6	72.14	25.19	71.90	25.41	71.90	26.31	71.67	26.77	69.29	25.46	63.57	24.23
	-5	-5.6	73.10	25.22	72.86	25.43	72.86	25.70	72.14	26.01	69.29	24.70	63.57	23.55
	-3	-3.7	74.52	25.25	74.29	25.44	74.29	24.85	72.14	24.51	69.29	23.92	63.57	22.77
	0	-0.7	76.43	25.28	80.71	25.46	75.00	24.16	72.14	23.39	69.29	22.75	63.57	21.78
	3	2.2	81.43	24.77	80.71	24.82	75.00	23.47	72.14	22.26	69.29	21.39	63.57	20.71
	5	4.1	86.43	24.38	80.71	23.61	75.00	22.36	72.14	21.25	69.29	20.52	63.57	19.79
90%	7	6	86.43	24.07	80.71	22.40	75.00	20.94	72.14	20.12	69.29	19.69	63.57	18.92
	9	7.9	86.43	22.70	80.71	21.21	75.00	20.35	72.14	19.63	69.29	19.11	63.57	18.31
	11	9.8	86.43	21.24	80.71	19.91	75.00	19.68	72.14	18.83	69.29	18.41	63.57	17.54
	13	11.8	86.43	19.91	80.71	19.41	75.00	18.92	72.14	18.16	69.29	17.75	63.57	16.94
	15	13.7	86.43	18.94	80.71	18.59	75.00	18.22	72.14	17.53	69.29	17.12	63.57	16.28
	-25	-25.4	58.25	24.86	57.93	25.09	57.74	25.38	57.70	25.70	57.70	25.80	57.14	24.18
	-19.8	-20	60.71	25.28	60.48	25.52	60.24	25.79	60.24	25.95	60.24	26.10	57.14	23.67
	-18.8	-19	61.19	25.31	60.95	25.55	60.71	25.82	60.71	25.98	60.71	26.01	57.14	23.43
	-16.7	-17	62.14	25.34	61.90	25.58	61.90	25.86	61.67	26.01	61.67	25.49	57.14	22.94
	-13.7	-15	63.10	25.37	62.86	25.64	62.86	25.92	62.62	26.04	62.38	24.98	57.14	22.49
	-11.8	-13	64.05	25.43	63.81	25.67	63.81	25.95	63.57	25.70	62.38	24.46	57.14	22.06
	-9.8	-11	65.00	25.46	65.00	25.73	64.76	25.98	64.76	25.19	62.38	24.00	57.14	21.64
	-9.5	-10	65.48	25.49	65.48	25.73	65.24	26.01	65.00	24.94	62.38	23.76	57.14	21.42
	-8.5	-9.1	65.95	25.52	65.71	25.76	65.71	25.95	65.00	24.73	62.38	23.55	57.14	21.24
	-7	-7.6	66.67	25.55	66.67	25.42	66.43	25.58	65.00	24.40	62.38	23.22	57.14	20.94
-5	-5.6	71.90	25.60	71.67	24.32	67.62	24.51	65.00	23.58	62.38	22.49	57.14	20.33	
-3	-3.7	72.86	25.63	72.62	23.25	67.62	23.30	65.00	22.71	62.38	21.77	57.14	19.81	
0	-0.7	74.29	25.67	72.62	22.08	67.62	22.30	65.00	21.62	62.38	20.70	57.14	19.30	
3	2.2	77.86	25.70	72.62	20.92	67.62	21.04	65.00	20.80	62.38	19.77	57.14	18.65	
5	4.1	77.86	25.07	72.62	19.89	67.62	20.09	65.00	19.73	62.38	18.85	57.14	17.90	
7	6	77.86	21.79	72.62	19.52	67.62	18.78	65.00	18.06	62.38	17.36	57.14	15.93	
9	7.9	77.86	20.45	72.62	19.15	67.62	17.84	65.00	17.21	62.38	16.57	57.14	15.32	
11	9.8	77.86	19.27	72.62	18.12	67.62	16.99	65.00	16.42	62.38	15.87	57.14	14.78	
13	11.8	77.86	18.21	72.62	17.21	67.62	16.24	65.00	15.75	62.38	15.26	57.14	14.29	
15	13.7	77.86	17.45	72.62	16.57	67.62	15.69	65.00	15.26	62.38	14.84	57.14	13.96	
80%	-25	-25.4	58.17	26.36	57.93	26.69	58.20	25.88	57.62	24.65	55.48	23.60	50.71	21.39
	-19.8	-20	60.48	25.38	60.24	25.65	60.00	24.78	57.62	23.64	55.48	22.53	50.71	20.35
	-18.8	-19	60.95	25.41	60.71	25.65	60.00	24.54	57.62	23.40	55.48	22.30	50.71	20.14
	-16.7	-17	61.90	25.44	61.67	25.71	60.00	24.03	57.62	22.92	55.48	21.85	50.71	19.72
	-13.7	-15	62.86	25.50	62.62	25.74	60.00	23.55	57.62	22.47	55.48	21.43	50.71	19.36
	-11.8	-13	63.81	25.53	63.57	25.26	60.00	23.07	57.62	22.03	55.48	21.01	50.71	19.00
	-9.8	-11	64.76	25.56	64.52	24.75	60.00	22.65	57.62	21.61	55.48	20.62	50.71	18.64
	-9.5	-10	65.24	25.59	64.52	24.51	60.00	22.41	57.62	21.40	55.48	20.41	50.71	18.46
	-8.5	-9.1	65.71	25.62	64.52	24.30	60.00	22.24	57.62	21.22	55.48	20.23	50.71	18.31
	-7	-7.6	66.43	25.65	64.52	23.94	60.00	21.94	57.62	20.95	55.48	19.96	50.71	18.07
	-5	-5.6	69.29	25.14	64.52	23.16	60.00	21.25	57.62	20.29	55.48	19.39	50.71	17.56
-3	-3.7	69.29	26.01	64.52	22.32	60.00	20.34	57.62	19.52	55.48	18.68	50.71	17.06	
0	-0.7	69.29	25.68	64.52	21.29	60.00	19.64	57.62	18.95	55.48	18.13	50.71	16.67	

	3	2.2	69.29	23.73	64.52	20.09	60.00	18.53	57.62	18.28	55.48	17.44	50.71	16.02
	5	4.1	69.29	21.70	64.52	18.98	60.00	17.67	57.62	17.53	55.48	16.62	50.71	15.67
	7	6	69.29	19.03	64.52	17.77	60.00	16.51	57.62	15.88	55.48	15.28	50.71	14.08
	9	7.9	69.29	18.04	64.52	16.93	60.00	15.82	57.62	15.28	55.48	14.71	50.71	13.66
	11	9.8	69.29	17.14	64.52	16.15	60.00	15.19	57.62	14.71	55.48	14.23	50.71	13.31
	13	11.8	69.29	16.36	64.52	15.49	60.00	14.65	57.62	14.23	55.48	13.81	50.71	12.98
	15	13.7	69.29	15.79	64.52	15.01	60.00	14.26	57.62	13.90	55.48	13.51	50.71	12.77

Abbreviations:

CR: Combination ratio

TC: Total capacity (kW)

PI: Power input (compressor + outdoor fan motor) (kW)

Notes:

Shaded cells indicate rating condition.

Table 2-8.22: 24HP heating capacity (continued)

CR	Outdoor air temp.		Indoor air temp. °C DB											
			16		18		20		21		22		24	
	°C DB	°C WB	TC	PI	TC	PI	TC	PI	TC	PI	TC	PI	TC	PI
70%	-25	-25.4	60.00	26.67	56.43	24.67	52.62	24.25	50.48	23.81	48.57	23.51	44.52	22.63
	-19.8	-20	60.00	25.40	56.43	23.37	52.62	22.90	50.48	22.45	48.57	22.16	44.52	21.28
	-18.8	-19	60.48	25.13	56.43	23.12	52.62	22.65	50.48	22.21	48.57	21.92	44.52	21.03
	-16.7	-17	60.48	24.61	56.43	22.67	52.62	22.26	50.48	21.82	48.57	21.52	44.52	20.64
	-13.7	-15	60.48	24.13	56.43	22.21	52.62	21.83	50.48	21.39	48.57	21.10	44.52	20.22
	-11.8	-13	60.48	23.64	56.43	21.79	52.62	21.47	50.48	21.03	48.57	20.73	44.52	19.85
	-9.8	-11	60.48	23.18	56.43	21.36	52.62	21.08	50.48	20.63	48.57	20.34	44.52	19.46
	-9.5	-10	60.48	22.97	56.43	21.18	52.62	20.54	50.48	20.10	48.57	19.81	44.52	18.93
	-8.5	-9.1	60.48	22.76	56.43	21.00	52.62	19.86	50.48	19.42	48.57	19.12	44.52	18.24
	-7	-7.6	60.48	22.46	56.43	20.70	52.62	19.00	50.48	18.56	48.57	18.26	44.52	17.38
	-5	-5.6	60.48	21.76	56.43	20.09	52.62	18.48	50.48	18.04	48.57	17.75	44.52	16.86
	-3	-3.7	60.48	20.59	56.43	19.48	52.62	17.94	50.48	17.50	48.57	17.20	44.52	16.32
	0	-0.7	60.48	19.50	56.43	18.63	52.62	17.18	50.48	16.73	48.57	16.44	44.52	15.56
	3	2.2	60.48	18.40	56.43	17.62	52.62	16.13	50.48	15.69	48.57	15.39	44.52	14.51
	5	4.1	60.48	17.56	56.43	16.49	52.62	15.52	50.48	15.08	48.57	14.79	44.52	13.90
60%	-25	-25.4	51.90	24.86	48.57	23.51	45.00	22.42	43.33	21.91	41.43	20.99	38.10	19.90
	-19.8	-20	51.90	23.54	48.57	22.42	45.00	21.57	43.33	20.95	41.43	20.01	38.10	18.87
	-18.8	-19	51.90	22.94	48.57	21.65	45.00	20.80	43.33	20.25	41.43	19.23	38.10	18.19
	-16.7	-17	51.90	22.22	48.57	20.98	45.00	20.16	43.33	19.47	41.43	18.51	38.10	17.47
	-13.7	-15	51.90	21.45	48.57	20.36	45.00	19.53	43.33	18.74	41.43	17.78	38.10	16.74
	-11.8	-13	51.90	20.69	48.57	19.60	45.00	18.78	43.33	18.10	41.43	17.03	38.10	15.99
	-9.8	-11	51.90	20.03	48.57	18.88	45.00	17.89	43.33	17.27	41.43	16.30	38.10	15.41
	-9.5	-10	51.90	19.31	48.57	18.12	45.00	17.15	43.33	16.53	41.43	15.59	38.10	14.57
	-8.5	-9.1	51.90	18.51	48.57	17.47	45.00	16.43	43.33	15.82	41.43	14.86	38.10	13.73
	-7	-7.6	51.90	17.82	48.57	16.72	45.00	15.87	43.33	15.29	41.43	14.29	38.10	13.14
	-5	-5.6	51.90	17.16	48.57	16.10	45.00	15.08	43.33	14.66	41.43	13.72	38.10	12.51
	-3	-3.7	51.90	16.56	48.57	15.47	45.00	14.40	43.33	14.07	41.43	13.11	38.10	12.07
	0	-0.7	51.90	15.90	48.57	14.85	45.00	13.76	43.33	13.39	41.43	12.46	38.10	11.84
	3	2.2	51.90	15.17	48.57	14.14	45.00	13.23	43.33	12.85	41.43	11.82	38.10	11.41
	5	4.1	51.90	14.40	48.57	13.54	45.00	12.74	43.33	12.27	41.43	11.55	38.10	11.17
50%	-25	-25.4	43.33	20.58	40.48	19.46	37.62	18.56	35.95	18.14	34.52	17.68	31.67	16.47
	-19.8	-20	43.33	19.49	40.48	18.56	37.62	17.85	35.95	17.35	34.52	16.86	31.67	15.62
	-18.8	-19	43.33	18.99	40.48	17.93	37.62	17.22	35.95	16.77	34.52	16.22	31.67	15.06
	-16.7	-17	43.33	18.40	40.48	17.37	37.62	16.69	35.95	16.12	34.52	15.62	31.67	14.46
	-13.7	-15	43.33	17.76	40.48	16.85	37.62	16.17	35.95	15.52	34.52	15.02	31.67	13.86
	-11.8	-13	43.33	17.13	40.48	16.23	37.62	15.55	35.95	14.98	34.52	14.40	31.67	13.24
	-9.8	-11	43.33	16.58	40.48	15.63	37.62	14.81	35.95	14.30	34.52	13.80	31.67	12.75
	-9.5	-10	43.33	15.99	40.48	15.00	37.62	14.20	35.95	13.69	34.52	13.21	31.67	12.06
	-8.5	-9.1	43.33	15.32	40.48	14.46	37.62	13.61	35.95	13.10	34.52	12.61	31.67	11.37
	-7	-7.6	43.33	14.75	40.48	13.84	37.62	13.14	35.95	12.66	34.52	12.13	31.67	10.87
	-5	-5.6	43.33	14.21	40.48	13.33	37.62	12.48	35.95	12.13	34.52	11.66	31.67	10.36
	-3	-3.7	43.33	13.71	40.48	12.80	37.62	11.92	35.95	11.65	34.52	11.15	31.67	9.99

MDV6 VRF 50Hz



	0	-0.7	43.33	13.16	40.48	12.30	37.62	11.39	35.95	11.09	34.52	10.62	31.67	9.80
	3	2.2	43.33	12.56	40.48	11.71	37.62	10.95	35.95	10.64	34.52	10.09	31.67	9.75
	5	4.1	43.33	11.92	40.48	11.21	37.62	10.55	35.95	10.16	34.52	9.87	31.67	9.65
	7	6	43.33	11.37	40.48	10.73	37.62	10.06	35.95	9.75	34.52	9.71	31.67	9.37
	9	7.9	43.33	11.18	40.48	10.49	37.62	9.90	35.95	9.52	34.52	9.31	31.67	9.07
	11	9.8	43.33	11.01	40.48	10.34	37.62	9.64	35.95	9.29	34.52	9.14	31.67	8.91
	13	11.8	43.33	10.67	40.48	9.99	37.62	9.34	35.95	9.09	34.52	8.94	31.67	8.72
	15	13.7	43.33	10.54	40.48	9.79	37.62	9.07	35.95	8.87	34.52	8.70	31.67	8.48

Abbreviations:

CR: Combination ratio

TC: Total capacity (kW)

PI: Power input (compressor + outdoor fan motor) (kW)

Notes: Shaded cells indicate rating condition.

Table 2-8.23: 26HP heating capacity

CR	Outdoor air temp.		Indoor air temp. °C DB											
			16		18		20		21		22		24	
	°C DB	°C WB	TC kW	PI kW	TC kW	PI kW	TC kW	PI kW	TC kW	PI kW	TC kW	PI kW	TC kW	PI kW
130%	-25	-25.4	63.58	21.39	63.32	21.76	62.00	22.63	61.80	23.27	61.74	23.91	61.38	24.29
	-19.8	-20	66.83	21.96	66.57	22.43	66.31	23.56	66.05	24.20	66.05	24.84	65.79	25.15
	-18.8	-19	67.34	22.36	67.08	22.72	66.83	23.78	66.83	24.42	66.57	25.06	66.31	25.29
	-16.7	-17	68.37	22.60	68.12	23.13	67.86	24.03	67.86	24.67	67.60	25.31	67.34	25.73
	-13.7	-15	69.41	22.87	69.15	23.48	68.89	24.46	68.89	25.10	68.63	25.74	68.37	26.08
	-11.8	-13	70.44	23.26	70.18	23.86	69.92	24.91	69.92	25.55	69.66	26.19	69.66	26.47
	-9.8	-11	71.47	23.61	71.21	24.28	70.95	25.17	70.95	25.81	70.95	26.45	70.70	26.51
	-9.5	-10	71.99	23.97	71.73	24.52	71.73	25.56	71.47	26.20	71.47	26.84	71.21	26.91
	-8.5	-9.1	72.50	24.29	72.24	24.87	71.99	25.84	71.99	26.48	71.99	27.12	71.73	27.22
	-7	-7.6	73.28	24.32	73.02	25.22	73.02	26.08	72.76	26.69	72.76	27.51	72.50	27.57
	-5	-5.6	78.95	25.39	78.70	25.93	78.44	26.90	78.44	27.71	78.18	27.68	77.92	27.90
	-3	-3.7	79.99	26.00	79.73	26.35	79.47	27.34	79.47	28.15	79.21	28.04	78.95	28.25
	0	-0.7	81.53	26.76	81.28	26.61	81.02	27.68	81.02	28.45	80.76	28.47	80.76	28.48
	3	2.2	90.07	28.29	89.02	28.33	88.76	29.12	88.50	29.66	88.50	29.97	88.24	30.21
	5	4.1	111.98	34.18	107.49	33.78	105.79	33.64	101.66	32.57	97.53	32.21	89.53	30.81
7	6	113.79	34.46	109.55	32.87	105.79	32.00	101.66	31.18	97.53	30.87	89.53	29.75	
9	7.9	113.79	32.78	109.55	31.30	105.79	31.03	101.66	30.60	97.53	30.09	89.53	29.07	
11	9.8	113.79	31.19	109.55	30.02	105.79	29.96	101.66	29.58	97.53	29.20	89.53	27.95	
13	11.8	113.79	29.67	109.55	29.13	105.79	29.13	101.66	29.07	97.53	28.56	89.53	27.45	
15	13.7	113.79	28.74	109.55	28.48	105.79	28.32	101.66	27.93	97.53	27.74	89.53	26.44	
120%	-25	-25.4	62.96	23.31	62.70	24.16	62.64	25.01	62.44	25.61	62.16	26.22	61.97	26.59
	-19.8	-20	66.75	23.94	66.49	24.75	66.23	25.46	66.23	26.07	65.98	26.67	65.72	27.13
	-18.8	-19	67.27	24.28	67.01	24.78	66.75	25.90	66.75	26.50	66.49	27.11	66.23	27.43
	-16.7	-17	68.30	24.64	68.05	25.14	67.79	26.25	67.79	26.85	67.53	27.46	67.53	27.53
	-13.7	-15	69.34	24.96	69.08	25.65	68.82	26.37	68.82	26.98	68.82	27.58	68.56	27.81
	-11.8	-13	70.37	25.33	70.12	25.92	69.97	26.72	69.86	27.32	69.86	27.92	69.60	28.12
	-9.8	-11	71.41	25.47	71.15	26.10	71.15	27.02	70.89	27.62	70.89	28.23	70.63	28.64
	-9.5	-10	71.93	25.76	71.67	26.30	71.67	27.20	71.41	27.81	71.41	28.41	71.15	29.00
	-8.5	-9.1	72.44	26.01	72.19	26.64	72.19	27.51	71.93	28.12	71.93	28.72	71.67	29.03
	-7	-7.6	73.22	26.48	72.96	27.12	72.96	27.82	72.70	28.42	72.70	29.03	72.44	29.36
	-5	-5.6	78.91	26.69	78.65	27.33	78.40	28.11	78.40	28.71	78.40	29.32	78.14	29.86
	-3	-3.7	79.95	27.16	79.69	27.78	79.43	28.47	79.43	29.08	79.17	29.68	79.17	30.01
	0	-0.7	81.50	27.50	81.24	28.16	80.98	28.71	80.98	29.32	80.98	29.92	80.72	30.22
	3	2.2	89.00	29.17	89.00	29.94	88.74	30.18	88.49	30.78	88.49	31.39	82.79	29.92
	5	4.1	112.03	32.70	105.30	32.36	97.80	31.83	93.92	31.19	90.30	30.85	82.79	29.01
7	6	112.81	32.46	105.30	31.00	97.80	30.22	93.92	29.69	90.30	29.51	82.79	28.30	
9	7.9	112.81	31.05	105.30	29.62	97.80	29.30	93.92	28.71	90.30	28.67	82.79	27.44	
11	9.8	112.81	30.04	105.30	29.00	97.80	28.30	93.92	27.87	90.30	27.63	82.79	26.42	
13	11.8	112.81	29.32	105.30	28.26	97.80	27.51	93.92	27.44	90.30	27.13	82.79	25.90	
15	13.7	112.81	28.67	105.30	27.42	97.80	26.75	93.92	26.43	90.30	26.21	82.79	24.95	
110%	-25	-25.4	63.74	24.00	63.44	24.55	63.13	25.11	63.22	24.73	62.99	25.21	62.96	25.86
	-19.8	-20	66.49	24.34	66.23	24.90	65.98	25.46	65.98	25.07	65.72	25.54	65.72	26.19
	-18.8	-19	67.01	24.71	66.75	25.26	66.49	25.82	66.49	25.11	66.23	25.82	66.23	26.27
	-16.7	-17	68.05	25.06	67.79	25.62	67.53	26.18	67.53	25.59	67.53	26.13	67.27	26.61
	-13.7	-15	69.08	25.29	68.82	25.84	68.56	26.40	68.56	25.75	68.56	26.25	68.30	26.89
	-11.8	-13	70.12	25.66	69.86	26.22	69.86	26.78	69.60	26.01	69.60	26.56	69.34	27.21
	-9.8	-11	71.15	25.66	70.89	26.22	70.89	26.78	70.63	26.49	70.63	26.88	70.37	27.56
	-9.5	-10	71.67	25.95	71.67	26.50	71.41	27.06	71.15	26.58	71.15	27.19	70.89	27.84
	-8.5	-9.1	72.19	26.23	71.93	26.79	71.93	27.34	71.67	26.83	71.67	27.47	71.41	28.15
	-7	-7.6	72.96	26.51	72.70	27.07	72.70	27.63	72.44	27.23	72.44	27.79	72.19	28.23
-5	-5.6	78.65	26.86	78.40	27.42	78.14	27.98	78.14	27.49	78.14	27.95	75.81	27.93	
-3	-3.7	79.69	27.06	79.43	27.62	79.17	28.17	79.17	27.73	79.17	28.31	75.81	27.45	

	0	-0.7	81.24	27.71	80.98	28.27	80.98	28.83	80.72	27.95	80.72	28.57	75.81	27.06
	3	2.2	88.74	28.95	88.74	29.51	88.49	30.07	86.16	29.07	82.79	28.78	75.81	26.83
	5	4.1	103.49	31.59	96.51	31.51	89.78	29.38	86.16	28.55	82.79	28.05	75.81	26.72
	7	6	103.49	30.42	96.51	29.68	89.78	27.89	86.16	27.15	82.79	26.74	75.81	26.05
	9	7.9	103.49	29.04	96.51	28.08	89.78	26.90	86.16	26.47	82.79	26.18	75.81	25.61
	11	9.8	103.49	28.00	96.51	27.05	89.78	26.13	86.16	25.51	82.79	25.33	75.81	24.76
	13	11.8	103.49	27.18	96.51	26.20	89.78	25.30	86.16	24.77	82.79	24.47	75.81	23.91
	15	13.7	103.49	26.41	96.51	25.34	89.78	24.46	86.16	23.92	82.79	23.64	75.81	23.07

Abbreviations:

CR: Combination ratio

TC: Total capacity (kW)

PI: Power input (compressor + outdoor fan motor) (kW)

Notes:

Shaded cells indicate rating condition.

Table 2-8.23: 26HP heating capacity (continued)

CR	Outdoor air temp.		Indoor air temp. °C DB											
			16		18		20		21		22		24	
	°C DB	°C WB	TC kW	PI kW	TC kW	PI kW	TC kW	PI kW	TC kW	PI kW	TC kW	PI kW	TC kW	PI kW
100%	-25	-25.4	63.79	29.98	63.53	30.27	63.27	30.45	63.27	30.78	63.27	30.96	63.01	31.37
	-19.8	-20	66.75	29.98	66.49	30.31	66.23	30.64	66.23	30.82	66.23	31.00	65.98	31.15
	-18.8	-19	67.79	30.05	67.53	30.38	67.27	30.71	67.27	30.86	67.27	31.04	67.01	30.90
	-16.7	-17	68.82	30.09	68.56	30.42	68.56	30.75	68.30	30.93	68.30	31.11	68.05	30.75
	-13.7	-15	69.86	30.16	69.60	30.45	69.60	30.82	69.34	30.96	69.34	31.15	69.08	30.38
	-11.8	-13	70.89	30.20	70.63	30.53	70.63	30.86	70.37	31.04	70.37	31.18	69.08	30.04
	-9.8	-11	71.41	30.23	71.41	30.56	71.15	30.89	71.15	31.04	70.89	31.22	69.08	30.00
	-9.5	-10	71.93	30.27	71.67	30.56	71.67	30.97	71.41	31.07	71.41	31.26	69.08	29.75
	-8.5	-9.1	72.70	30.31	72.70	30.60	72.44	31.07	72.19	31.11	72.19	31.29	69.08	29.29
	-7	-7.6	78.40	30.34	78.14	30.61	78.14	31.70	77.88	32.24	75.29	30.67	69.08	29.19
	-5	-5.6	79.43	30.38	79.17	30.63	79.17	30.96	78.40	31.33	75.29	29.76	69.08	28.37
	-3	-3.7	80.98	30.42	80.72	30.65	80.72	29.94	78.40	29.52	75.29	28.81	69.08	27.43
	0	-0.7	83.05	30.45	87.71	30.67	81.50	29.11	78.40	28.18	75.29	27.40	69.08	26.23
	3	2.2	88.49	29.84	87.71	29.90	81.50	28.27	78.40	26.81	75.29	25.77	69.08	24.95
	5	4.1	93.92	29.37	87.71	28.44	81.50	26.94	78.40	25.61	75.29	24.72	69.08	23.84
7	6	93.92	29.00	87.71	26.98	81.50	25.23	78.40	24.24	75.29	23.72	69.08	22.79	
9	7.9	93.92	27.35	87.71	25.55	81.50	24.52	78.40	23.64	75.29	23.02	69.08	22.06	
11	9.8	93.92	25.59	87.71	23.98	81.50	23.71	78.40	22.69	75.29	22.17	69.08	21.13	
13	11.8	93.92	23.98	87.71	23.39	81.50	22.79	78.40	21.88	75.29	21.39	69.08	20.41	
15	13.7	93.92	22.81	87.71	22.40	81.50	21.95	78.39	21.11	75.29	20.62	69.08	19.61	
90%	-25	-25.4	63.30	29.95	62.95	30.23	62.75	30.57	62.70	30.97	62.70	31.08	62.10	29.12
	-19.8	-20	65.98	30.45	65.72	30.75	65.46	31.07	65.46	31.26	65.46	31.44	62.10	28.52
	-18.8	-19	66.49	30.49	66.23	30.78	65.98	31.11	65.98	31.29	65.98	31.33	62.10	28.22
	-16.7	-17	67.53	30.53	67.27	30.82	67.27	31.15	67.01	31.33	67.01	30.71	62.10	27.64
	-13.7	-15	68.56	30.56	68.30	30.89	68.30	31.22	68.05	31.37	67.79	30.09	62.10	27.09
	-11.8	-13	69.60	30.64	69.34	30.93	69.34	31.26	69.08	30.96	67.79	29.47	62.10	26.58
	-9.8	-11	70.63	30.67	70.63	31.00	70.37	31.29	70.37	30.34	67.79	28.92	62.10	26.07
	-9.5	-10	71.15	30.71	71.15	31.00	70.89	31.33	70.63	30.05	67.79	28.62	62.10	25.81
	-8.5	-9.1	71.67	30.75	71.41	31.04	71.41	31.26	70.63	29.79	67.79	28.37	62.10	25.59
	-7	-7.6	72.44	30.78	72.44	30.62	72.19	30.82	70.63	29.39	67.79	27.97	62.10	25.23
	-5	-5.6	78.14	30.83	77.88	29.30	73.48	29.53	70.63	28.41	67.79	27.09	62.10	24.49
	-3	-3.7	79.17	30.88	78.91	28.01	73.48	28.07	70.63	27.36	67.79	26.23	62.10	23.87
	0	-0.7	80.72	30.92	78.91	26.60	73.48	26.87	70.63	26.05	67.79	24.94	62.10	23.26
	3	2.2	84.60	30.96	78.91	25.20	73.48	25.35	70.63	25.06	67.79	23.82	62.10	22.47
	5	4.1	84.60	30.20	78.91	23.96	73.48	24.20	70.63	23.77	67.79	22.71	62.10	21.57
7	6	84.60	26.25	78.91	23.52	73.48	22.63	70.63	21.75	67.79	20.91	62.10	19.19	
9	7.9	84.60	24.64	78.91	23.07	73.48	21.50	70.63	20.73	67.79	19.96	62.10	18.46	
11	9.8	84.60	23.21	78.91	21.83	73.48	20.47	70.63	19.78	67.79	19.12	62.10	17.80	
13	11.8	84.60	21.93	78.91	20.73	73.48	19.56	70.63	18.97	67.79	18.39	62.10	17.22	
15	13.7	84.60	21.02	78.91	19.96	73.48	18.90	70.63	18.39	67.79	17.88	62.10	16.82	
80%	-25	-25.4	63.21	31.76	62.95	32.15	63.24	31.18	62.61	29.70	60.28	28.43	55.11	25.77
	-19.8	-20	65.72	30.58	65.46	30.90	65.20	29.85	62.61	28.48	60.28	27.15	55.11	24.51
	-18.8	-19	66.23	30.61	65.98	30.90	65.20	29.57	62.61	28.19	60.28	26.86	55.11	24.26
	-16.7	-17	67.27	30.65	67.01	30.97	65.20	28.95	62.61	27.62	60.28	26.32	55.11	23.75
	-13.7	-15	68.30	30.72	68.05	31.01	65.20	28.37	62.61	27.08	60.28	25.81	55.11	23.32
	-11.8	-13	69.34	30.76	69.08	30.43	65.20	27.80	62.61	26.53	60.28	25.31	55.11	22.89
	-9.8	-11	70.37	30.79	70.12	29.82	65.20	27.29	62.61	26.03	60.28	24.84	55.11	22.45
	-9.5	-10	70.89	30.83	70.12	29.53	65.20	27.00	62.61	25.78	60.28	24.58	55.11	22.24
	-8.5	-9.1	71.41	30.87	70.12	29.28	65.20	26.79	62.61	25.56	60.28	24.37	55.11	22.06
	-7	-7.6	72.19	30.90	70.12	28.84	65.20	26.43	62.61	25.23	60.28	24.04	55.11	21.77
-5	-5.6	75.29	30.29	70.12	27.91	65.20	25.60	62.61	24.44	60.28	23.36	55.11	21.15	

MDV6 VRF 50Hz



	-3	-3.7	75.29	31.34	70.12	26.89	65.20	24.51	62.61	23.52	60.28	22.51	55.11	20.56
	0	-0.7	75.29	30.93	70.12	25.65	65.20	23.66	62.61	22.83	60.28	21.84	55.11	20.08
	3	2.2	75.29	28.59	70.12	24.20	65.20	22.32	62.61	22.02	60.28	21.01	55.11	19.29
	5	4.1	75.29	26.14	70.12	22.87	65.20	21.29	62.61	21.12	60.28	20.02	55.11	18.88
	7	6	75.29	22.92	70.12	21.41	65.20	19.89	62.61	19.13	60.28	18.41	55.11	16.97
	9	7.9	75.29	21.73	70.12	20.40	65.20	19.06	62.61	18.41	60.28	17.73	55.11	16.46
	11	9.8	75.29	20.65	70.12	19.46	65.20	18.30	62.61	17.73	60.28	17.15	55.11	16.03
	13	11.8	75.29	19.71	70.12	18.66	65.20	17.65	62.61	17.15	60.28	16.64	55.11	15.63
	15	13.7	75.29	19.02	70.12	18.09	65.20	17.18	62.61	16.75	60.28	16.28	55.11	15.38

Abbreviations:

CR: Combination ratio

TC: Total capacity (kW)

PI: Power input (compressor + outdoor fan motor) (kW)

Notes:

Shaded cells indicate rating condition.

Table 2-8.23: 26HP heating capacity (continued)

CR	Outdoor air temp.		Indoor air temp. °C DB											
			16		18		20		21		22		24	
	°C DB	°C WB	TC kW	PI kW	TC kW	PI kW	TC kW	PI kW	TC kW	PI kW	TC kW	PI kW	TC kW	PI kW
70%	-25	-25.4	65.20	32.13	61.32	29.72	57.18	29.21	54.85	28.68	52.78	28.32	48.38	27.26
	-19.8	-20	65.20	30.60	61.32	28.15	57.18	27.58	54.85	27.05	52.78	26.70	48.38	25.63
	-18.8	-19	65.72	30.27	61.32	27.86	57.18	27.29	54.85	26.76	52.78	26.40	48.38	25.34
	-16.7	-17	65.72	29.65	61.32	27.31	57.18	26.82	54.85	26.28	52.78	25.93	48.38	24.86
	-13.7	-15	65.72	29.06	61.32	26.76	57.18	26.30	54.85	25.77	52.78	25.42	48.38	24.35
	-11.8	-13	65.72	28.48	61.32	26.25	57.18	25.86	54.85	25.33	52.78	24.98	48.38	23.91
	-9.8	-11	65.72	27.93	61.32	25.74	57.18	25.39	54.85	24.86	52.78	24.50	48.38	23.44
	-9.5	-10	65.72	27.67	61.32	25.52	57.18	24.75	54.85	24.22	52.78	23.86	48.38	22.80
	-8.5	-9.1	65.72	27.42	61.32	25.30	57.18	23.92	54.85	23.39	52.78	23.04	48.38	21.97
	-7	-7.6	65.72	27.05	61.32	24.93	57.18	22.89	54.85	22.35	52.78	22.00	48.38	20.93
	-5	-5.6	65.72	26.21	61.32	24.20	57.18	22.26	54.85	21.73	52.78	21.38	48.38	20.31
	-3	-3.7	65.72	24.80	61.32	23.47	57.18	21.61	54.85	21.08	52.78	20.73	48.38	19.66
	0	-0.7	65.72	23.49	61.32	22.45	57.18	20.69	54.85	20.16	52.78	19.81	48.38	18.74
	3	2.2	65.72	22.16	61.32	21.22	57.18	19.43	54.85	18.90	52.78	18.54	48.38	17.48
	5	4.1	65.72	21.15	61.32	19.87	57.18	18.70	54.85	18.17	52.78	17.81	48.38	16.75
7	6	65.72	20.33	61.32	19.01	57.18	17.73	54.85	17.25	52.78	16.90	48.38	15.83	
9	7.9	65.72	19.45	61.32	18.28	57.18	17.15	54.85	16.61	52.78	16.26	48.38	15.20	
11	9.8	65.72	18.68	61.32	17.66	57.18	16.46	54.85	15.92	52.78	15.57	48.38	14.51	
13	11.8	65.72	17.99	61.32	16.93	57.18	15.66	54.85	15.13	52.78	14.78	48.38	13.71	
15	13.7	65.72	17.33	61.32	16.18	57.18	15.05	54.85	14.52	52.78	14.17	48.38	13.10	
60%	-25	-25.4	56.40	29.95	52.78	28.32	48.90	27.00	47.09	26.39	45.02	25.29	41.40	23.97
	-19.8	-20	56.40	28.36	52.78	27.01	48.90	25.98	47.09	25.24	45.02	24.10	41.40	22.73
	-18.8	-19	56.40	27.64	52.78	26.08	48.90	25.06	47.09	24.40	45.02	23.16	41.40	21.92
	-16.7	-17	56.40	26.77	52.78	25.28	48.90	24.29	47.09	23.45	45.02	22.29	41.40	21.04
	-13.7	-15	56.40	25.84	52.78	24.52	48.90	23.53	47.09	22.58	45.02	21.42	41.40	20.17
	-11.8	-13	56.40	24.93	52.78	23.61	48.90	22.63	47.09	21.80	45.02	20.51	41.40	19.27
	-9.8	-11	56.40	24.12	52.78	22.74	48.90	21.55	47.09	20.81	45.02	19.64	41.40	18.56
	-9.5	-10	56.40	23.26	52.78	21.83	48.90	20.66	47.09	19.92	45.02	18.78	41.40	17.55
	-8.5	-9.1	56.40	22.29	52.78	21.04	48.90	19.80	47.09	19.06	45.02	17.90	41.40	16.55
	-7	-7.6	56.40	21.47	52.78	20.14	48.90	19.11	47.09	18.42	45.02	17.21	41.40	15.82
	-5	-5.6	56.40	20.67	52.78	19.40	48.90	18.16	47.09	17.66	45.02	16.52	41.40	15.07
	-3	-3.7	56.40	19.95	52.78	18.63	48.90	17.35	47.09	16.95	45.02	15.79	41.40	14.54
	0	-0.7	56.40	19.15	52.78	17.89	48.90	16.57	47.09	16.13	45.02	15.01	41.40	14.26
	3	2.2	56.40	18.27	52.78	17.04	48.90	15.94	47.09	15.48	45.02	14.24	41.40	13.75
	5	4.1	56.40	17.34	52.78	16.31	48.90	15.35	47.09	14.78	45.02	13.92	41.40	13.45
7	6	56.40	16.55	52.78	15.61	48.90	14.63	47.09	14.19	45.02	13.84	41.40	13.20	
9	7.9	56.40	16.26	52.78	15.26	48.90	14.41	47.09	13.85	45.02	13.26	41.40	12.62	
11	9.8	56.40	16.02	52.78	15.04	48.90	14.03	47.09	13.52	45.02	12.98	41.40	12.38	
13	11.8	56.40	15.52	52.78	14.54	48.90	13.59	47.09	13.23	45.02	12.71	41.40	12.10	
15	13.7	56.40	15.34	52.78	14.25	48.90	13.19	47.09	12.91	45.02	12.38	41.40	11.76	
50%	-25	-25.4	47.09	24.80	43.98	23.44	40.88	22.36	39.07	21.85	37.52	21.30	34.41	19.84
	-19.8	-20	47.09	23.48	43.98	22.36	40.88	21.51	39.07	20.90	37.52	20.32	34.41	18.82
	-18.8	-19	47.09	22.88	43.98	21.60	40.88	20.75	39.07	20.20	37.52	19.54	34.41	18.15
	-16.7	-17	47.09	22.16	43.98	20.93	40.88	20.11	39.07	19.42	37.52	18.82	34.41	17.42
	-13.7	-15	47.09	21.40	43.98	20.30	40.88	19.48	39.07	18.69	37.52	18.10	34.41	16.69
	-11.8	-13	47.09	20.64	43.98	19.55	40.88	18.73	39.07	18.05	37.52	17.34	34.41	15.95
	-9.8	-11	47.09	19.97	43.98	18.83	40.88	17.84	39.07	17.23	37.52	16.62	34.41	15.37
-9.5	-10	47.09	19.26	43.98	18.07	40.88	17.11	39.07	16.49	37.52	15.91	34.41	14.53	
-8.5	-9.1	47.09	18.46	43.98	17.42	40.88	16.39	39.07	15.78	37.52	15.19	34.41	13.70	
-7	-7.6	47.09	17.77	43.98	16.68	40.88	15.82	39.07	15.25	37.52	14.61	34.41	13.10	

-5	-5.6	47.09	17.11	43.98	16.06	40.88	15.04	39.07	14.62	37.52	14.04	34.41	12.48
-3	-3.7	47.09	16.52	43.98	15.42	40.88	14.36	39.07	14.03	37.52	13.44	34.41	12.04
0	-0.7	47.09	15.85	43.98	14.81	40.88	13.72	39.07	13.36	37.52	12.79	34.41	11.81
3	2.2	47.09	15.13	43.98	14.10	40.88	13.20	39.07	12.81	37.52	12.15	34.41	11.74
5	4.1	47.09	14.36	43.98	13.50	40.88	12.71	39.07	12.24	37.52	11.89	34.41	11.62
7	6	47.09	13.70	43.98	12.93	40.88	12.12	39.07	11.74	37.52	11.70	34.41	11.29
9	7.9	47.09	13.47	43.98	12.64	40.88	11.93	39.07	11.47	37.52	11.22	34.41	10.93
11	9.8	47.09	13.26	43.98	12.45	40.88	11.62	39.07	11.19	37.52	11.01	34.41	10.73
13	11.8	47.09	12.85	43.98	12.04	40.88	11.25	39.07	10.95	37.52	10.77	34.41	10.50
15	13.7	47.09	12.70	43.98	11.79	40.88	10.92	39.07	10.69	37.52	10.48	34.41	10.22

Abbreviations:

CR: Combination ratio

TC: Total capacity (kW)

PI: Power input (compressor + outdoor fan motor) (kW)

Notes: Shaded cells indicate rating condition.

Table 2-8.24: 28HP heating capacity

CR	Outdoor air temp.		Indoor air temp. °C DB											
			16		18		20		21		22		24	
	°C DB	°C WB	TC kW	PI kW	TC kW	PI kW	TC kW	PI kW	TC kW	PI kW	TC kW	PI kW	TC kW	PI kW
130%	-25	-25.4	65.65	24.23	65.38	24.64	64.02	25.62	63.81	26.35	63.76	27.07	63.38	27.50
	-19.8	-20	69.00	24.86	68.74	25.40	68.47	26.68	68.20	27.40	68.20	28.13	67.94	28.48
	-18.8	-19	69.54	25.31	69.27	25.73	69.00	26.92	69.00	27.65	68.74	28.37	68.47	28.63
	-16.7	-17	70.60	25.59	70.34	26.19	70.07	27.21	70.07	27.94	69.80	28.66	69.54	29.13
	-13.7	-15	71.67	25.89	71.40	26.58	71.14	27.69	71.14	28.42	70.87	29.14	70.60	29.53
	-11.8	-13	72.73	26.34	72.47	27.01	72.20	28.21	72.20	28.94	71.93	29.66	71.93	29.97
	-9.8	-11	73.80	26.74	73.53	27.49	73.27	28.50	73.27	29.23	73.27	29.95	73.00	30.01
	-9.5	-10	74.33	27.14	74.07	27.77	74.07	28.94	73.80	29.67	73.80	30.39	73.53	30.47
	-8.5	-9.1	74.87	27.50	74.60	28.17	74.33	29.26	74.33	29.99	74.33	30.71	74.07	30.82
	-7	-7.6	75.66	27.54	75.40	28.56	75.40	29.53	75.13	30.22	75.13	31.15	74.87	31.22
	-5	-5.6	81.53	28.75	81.26	29.36	80.99	30.46	80.99	31.38	80.73	31.35	80.46	31.59
	-3	-3.7	82.59	29.44	82.33	29.84	82.06	30.96	82.06	31.88	81.79	31.76	81.53	31.99
	0	-0.7	84.19	30.30	83.92	30.13	83.66	31.35	83.66	32.21	83.39	32.24	83.39	32.25
	3	2.2	93.01	32.04	91.92	32.08	91.65	32.97	91.38	33.59	91.38	33.93	91.12	34.21
	5	4.1	115.63	38.71	110.99	38.25	109.23	38.10	104.97	36.88	100.71	36.47	92.45	34.89
7	6	117.49	39.02	113.12	37.23	109.23	36.23	104.97	35.30	100.71	34.96	92.45	33.69	
9	7.9	117.49	37.11	113.12	35.44	109.23	35.13	104.97	34.65	100.71	34.08	92.45	32.92	
11	9.8	117.49	35.32	113.12	33.99	109.23	33.93	104.97	33.49	100.71	33.07	92.45	31.65	
13	11.8	117.49	33.60	113.12	32.99	109.23	32.98	104.97	32.92	100.71	32.35	92.45	31.08	
15	13.7	117.49	32.55	113.12	32.25	109.23	32.07	104.97	31.62	100.71	31.42	92.45	29.93	
120%	-25	-25.4	65.01	26.39	64.74	27.36	64.68	28.32	64.47	29.00	64.18	29.69	63.99	30.11
	-19.8	-20	68.93	27.11	68.66	28.02	68.39	28.83	68.39	29.52	68.13	30.20	67.86	30.72
	-18.8	-19	69.46	27.50	69.19	28.06	68.93	29.32	68.93	30.01	68.66	30.69	68.39	31.06
	-16.7	-17	70.53	27.91	70.26	28.47	70.00	29.72	70.00	30.41	69.73	31.09	69.73	31.18
	-13.7	-15	71.60	28.26	71.33	29.04	71.07	29.86	71.07	30.55	71.07	31.23	70.80	31.49
	-11.8	-13	72.67	28.69	72.40	29.35	72.25	30.25	72.13	30.94	72.13	31.62	71.87	31.84
	-9.8	-11	73.74	28.84	73.47	29.56	73.47	30.59	73.20	31.28	73.20	31.96	72.94	32.43
	-9.5	-10	74.27	29.17	74.00	29.78	74.00	30.81	73.74	31.49	73.74	32.17	73.47	32.84
	-8.5	-9.1	74.81	29.45	74.54	30.16	74.54	31.15	74.27	31.84	74.27	32.52	74.00	32.87
	-7	-7.6	75.61	29.98	75.34	30.71	75.34	31.50	75.07	32.18	75.07	32.87	74.81	33.25
	-5	-5.6	81.48	30.23	81.22	30.95	80.95	31.83	80.95	32.51	80.95	33.19	80.68	33.81
	-3	-3.7	82.55	30.76	82.29	31.45	82.02	32.24	82.02	32.92	81.75	33.61	81.75	33.99
	0	-0.7	84.16	31.14	83.89	31.89	83.62	32.51	83.62	33.20	83.62	33.88	83.35	34.22
	3	2.2	91.90	33.03	91.90	33.90	91.64	34.17	91.37	34.85	91.37	35.54	85.49	33.88
	5	4.1	115.68	37.02	108.73	36.65	100.99	36.05	96.98	35.32	93.24	34.94	85.49	32.85
7	6	116.48	36.76	108.73	35.11	100.99	34.22	96.98	33.62	93.24	33.42	85.49	32.05	
9	7.9	116.48	35.16	108.73	33.55	100.99	33.18	96.98	32.52	93.24	32.46	85.49	31.07	
11	9.8	116.48	34.02	108.73	32.84	100.99	32.04	96.98	31.56	93.24	31.29	85.49	29.92	
13	11.8	116.48	33.20	108.73	32.00	100.99	31.15	96.98	31.07	93.24	30.72	85.49	29.33	
15	13.7	116.48	32.46	108.73	31.05	100.99	30.28	96.98	29.93	93.24	29.68	85.49	28.25	
110%	-25	-25.4	65.81	27.17	65.51	27.80	65.18	28.44	65.28	28.00	65.04	28.54	65.01	29.29
	-19.8	-20	68.66	27.56	68.39	28.19	68.13	28.82	68.13	28.39	67.86	28.92	67.86	29.65
	-18.8	-19	69.19	27.97	68.93	28.61	68.66	29.24	68.66	28.43	68.39	29.24	68.39	29.75
	-16.7	-17	70.26	28.38	70.00	29.01	69.73	29.64	69.73	28.98	69.73	29.59	69.46	30.13
	-13.7	-15	71.33	28.63	71.07	29.26	70.80	29.90	70.80	29.16	70.80	29.72	70.53	30.45
	-11.8	-13	72.40	29.06	72.13	29.69	72.13	30.32	71.87	29.46	71.87	30.08	71.60	30.81
	-9.8	-11	73.47	29.06	73.20	29.69	73.20	30.32	72.94	30.00	72.94	30.43	72.67	31.21
	-9.5	-10	74.00	29.38	74.00	30.01	73.74	30.64	73.47	30.10	73.47	30.79	73.20	31.52
-8.5	-9.1	74.54	29.70	74.27	30.33	74.27	30.96	74.00	30.39	74.00	31.11	73.74	31.88	
-7	-7.6	75.34	30.02	75.07	30.65	75.07	31.28	74.81	30.83	74.81	31.46	74.54	31.97	

	-5	-5.6	81.22	30.42	80.95	31.05	80.68	31.68	80.68	31.13	80.68	31.64	78.28	31.62
	-3	-3.7	82.29	30.64	82.02	31.27	81.75	31.90	81.75	31.39	81.75	32.06	78.28	31.08
	0	-0.7	83.89	31.38	83.62	32.01	83.62	32.64	83.35	31.65	83.35	32.35	78.28	30.64
	3	2.2	91.64	32.78	91.64	33.41	91.37	34.04	88.96	32.92	85.49	32.58	78.28	30.38
	5	4.1	106.86	35.78	99.65	35.68	92.71	33.27	88.96	32.33	85.49	31.76	78.28	30.26
	7	6	106.86	34.45	99.65	33.60	92.71	31.59	88.96	30.74	85.49	30.28	78.28	29.50
	9	7.9	106.86	32.89	99.65	31.79	92.71	30.46	88.96	29.97	85.49	29.65	78.28	28.99
	11	9.8	106.86	31.71	99.65	30.63	92.71	29.59	88.96	28.89	85.49	28.68	78.28	28.03
	13	11.8	106.86	30.78	99.65	29.67	92.71	28.64	88.96	28.05	85.49	27.71	78.28	27.07
	15	13.7	106.86	29.90	99.65	28.69	92.71	27.69	88.96	27.09	85.49	26.77	78.28	26.12

Abbreviations:

CR: Combination ratio

TC: Total capacity (kW)

PI: Power input (compressor + outdoor fan motor) (kW)

Notes:

Shaded cells indicate rating condition.

Table 2-8.24: 28HP heating capacity (continued)

CR	Outdoor air temp.		Indoor air temp. °C DB											
			16		18		20		21		22		24	
	°C DB	°C WB	TC kW	PI kW	TC kW	PI kW	TC kW	PI kW	TC kW	PI kW	TC kW	PI kW	TC kW	PI kW
100%	-25	-25.4	65.87	33.95	65.60	34.28	65.33	34.48	65.33	34.86	65.33	35.06	65.07	35.52
	-19.8	-20	68.93	33.95	68.66	34.32	68.39	34.69	68.39	34.90	68.39	35.10	68.13	35.27
	-18.8	-19	70.00	34.03	69.73	34.40	69.46	34.77	69.46	34.94	69.46	35.15	69.19	34.99
	-16.7	-17	71.07	34.07	70.80	34.44	70.80	34.81	70.53	35.02	70.53	35.23	70.26	34.81
	-13.7	-15	72.13	34.15	71.87	34.48	71.87	34.90	71.60	35.06	71.60	35.27	71.33	34.40
	-11.8	-13	73.20	34.19	72.94	34.57	72.94	34.94	72.67	35.15	72.67	35.31	71.33	34.02
	-9.8	-11	73.74	34.23	73.74	34.61	73.47	34.98	73.47	35.15	73.20	35.35	71.33	33.97
	-9.5	-10	74.27	34.28	74.00	34.61	74.00	35.07	73.74	35.19	73.74	35.39	71.33	33.68
	-8.5	-9.1	75.07	34.32	75.07	34.65	74.81	35.18	74.54	35.23	74.54	35.44	71.33	33.17
	-7	-7.6	80.95	34.36	80.68	34.66	80.68	35.89	80.42	36.51	77.74	34.73	71.33	33.05
	-5	-5.6	82.02	34.40	81.75	34.68	81.75	35.06	80.95	35.48	77.74	33.70	71.33	32.13
	-3	-3.7	83.62	34.44	83.35	34.70	83.35	33.90	80.95	33.43	77.74	32.63	71.33	31.06
	0	-0.7	85.76	34.48	90.57	34.72	84.16	32.96	80.95	31.91	77.74	31.03	71.33	29.71
	3	2.2	91.37	33.79	90.57	33.86	84.16	32.02	80.95	30.36	77.74	29.18	71.33	28.25
	5	4.1	96.98	33.26	90.57	32.21	84.16	30.50	80.95	28.99	77.74	27.99	71.33	26.99
7	6	96.98	32.84	90.57	30.55	84.16	28.56	80.95	27.45	77.74	26.86	71.33	25.81	
9	7.9	96.98	30.96	90.57	28.94	84.16	27.76	80.95	26.77	77.74	26.06	71.33	24.97	
11	9.8	96.98	28.98	90.57	27.16	84.16	26.85	80.95	25.69	77.74	25.11	71.33	23.93	
13	11.8	96.98	27.16	90.57	26.48	84.16	25.81	80.95	24.78	77.74	24.22	71.33	23.11	
15	13.7	96.98	25.83	90.57	25.36	84.16	24.85	80.95	23.91	77.74	23.35	71.33	22.21	
90%	-25	-25.4	65.36	33.91	65.01	34.23	64.79	34.62	64.74	35.06	64.74	35.19	64.12	32.98
	-19.8	-20	68.13	34.48	67.86	34.81	67.59	35.19	67.59	35.39	67.59	35.60	64.12	32.29
	-18.8	-19	68.66	34.52	68.39	34.86	68.13	35.23	68.13	35.44	68.13	35.48	64.12	31.96
	-16.7	-17	69.73	34.57	69.46	34.90	69.46	35.27	69.19	35.48	69.19	34.77	64.12	31.30
	-13.7	-15	70.80	34.61	70.53	34.98	70.53	35.35	70.26	35.52	70.00	34.07	64.12	30.67
	-11.8	-13	71.87	34.69	71.60	35.02	71.60	35.39	71.33	35.06	70.00	33.37	64.12	30.10
	-9.8	-11	72.94	34.73	72.94	35.10	72.67	35.44	72.67	34.36	70.00	32.74	64.12	29.52
	-9.5	-10	73.47	34.77	73.47	35.10	73.20	35.48	72.94	34.03	70.00	32.41	64.12	29.23
	-8.5	-9.1	74.00	34.81	73.74	35.15	73.74	35.39	72.94	33.74	70.00	32.12	64.12	28.98
	-7	-7.6	74.81	34.86	74.81	34.67	74.54	34.90	72.94	33.28	70.00	31.67	64.12	28.56
	-5	-5.6	80.68	34.92	80.42	33.17	75.87	33.44	72.94	32.17	70.00	30.67	64.12	27.74
	-3	-3.7	81.75	34.96	81.48	31.71	75.87	31.78	72.94	30.98	70.00	29.70	64.12	27.03
	0	-0.7	83.35	35.01	81.48	30.12	75.87	30.42	72.94	29.50	70.00	28.24	64.12	26.33
	3	2.2	87.36	35.06	81.48	28.53	75.87	28.71	72.94	28.38	70.00	26.97	64.12	25.44
	5	4.1	87.36	34.19	81.48	27.13	75.87	27.40	72.94	26.92	70.00	25.72	64.12	24.42
7	6	87.36	29.72	81.48	26.63	75.87	25.62	72.94	24.63	70.00	23.68	64.12	21.73	
9	7.9	87.36	27.90	81.48	26.12	75.87	24.34	72.94	23.47	70.00	22.60	64.12	20.91	
11	9.8	87.36	26.29	81.48	24.71	75.87	23.18	72.94	22.40	70.00	21.65	64.12	20.16	
13	11.8	87.36	24.84	81.48	23.47	75.87	22.15	72.94	21.48	70.00	20.82	64.12	19.50	
15	13.7	87.36	23.80	81.48	22.60	75.87	21.40	72.94	20.82	70.00	20.24	64.12	19.04	
80%	-25	-25.4	65.27	35.96	65.00	36.40	65.31	35.31	64.65	33.63	62.25	32.19	56.91	29.19
	-19.8	-20	67.86	34.62	67.59	34.99	67.32	33.81	64.65	32.25	62.25	30.74	56.91	27.76
	-18.8	-19	68.39	34.66	68.13	34.99	67.32	33.48	64.65	31.93	62.25	30.41	56.91	27.47
	-16.7	-17	69.46	34.71	69.19	35.07	67.32	32.78	64.65	31.27	62.25	29.80	56.91	26.90
	-13.7	-15	70.53	34.79	70.26	35.11	67.32	32.13	64.65	30.66	62.25	29.23	56.91	26.41
	-11.8	-13	71.60	34.83	71.33	34.46	67.32	31.48	64.65	30.05	62.25	28.66	56.91	25.92
	-9.8	-11	72.67	34.87	72.40	33.77	67.32	30.90	64.65	29.47	62.25	28.12	56.91	25.43
	-9.5	-10	73.20	34.91	72.40	33.44	67.32	30.58	64.65	29.19	62.25	27.84	56.91	25.18
-8.5	-9.1	73.74	34.95	72.40	33.15	67.32	30.33	64.65	28.94	62.25	27.59	56.91	24.98	

-7	-7.6	74.54	34.99	72.40	32.66	67.32	29.92	64.65	28.57	62.25	27.22	56.91	24.65
-5	-5.6	77.74	34.30	72.40	31.60	67.32	28.98	64.65	27.67	62.25	26.45	56.91	23.95
-3	-3.7	77.74	35.48	72.40	30.45	67.32	27.75	64.65	26.63	62.25	25.49	56.91	23.28
0	-0.7	77.74	35.03	72.40	29.04	67.32	26.79	64.65	25.85	62.25	24.73	56.91	22.74
3	2.2	77.74	32.38	72.40	27.40	67.32	25.27	64.65	24.93	62.25	23.79	56.91	21.85
5	4.1	77.74	29.60	72.40	25.89	67.32	24.11	64.65	23.91	62.25	22.67	56.91	21.38
7	6	77.74	25.96	72.40	24.24	67.32	22.52	64.65	21.67	62.25	20.85	56.91	19.21
9	7.9	77.74	24.61	72.40	23.10	67.32	21.58	64.65	20.85	62.25	20.07	56.91	18.64
11	9.8	77.74	23.38	72.40	22.03	67.32	20.73	64.65	20.07	62.25	19.42	56.91	18.15
13	11.8	77.74	22.32	72.40	21.13	67.32	19.99	64.65	19.42	62.25	18.84	56.91	17.70
15	13.7	77.74	21.54	72.40	20.48	67.32	19.46	64.65	18.97	62.25	18.44	56.91	17.41

Abbreviations:

CR: Combination ratio

TC: Total capacity (kW)

PI: Power input (compressor + outdoor fan motor) (kW)

Notes: Shaded cells indicate rating condition.

Table 2-8.24: 28HP heating capacity (continued)

CR	Outdoor air temp.		Indoor air temp. °C DB											
			16		18		20		21		22		24	
	°C DB	°C WB	TC kW	PI kW	TC kW	PI kW	TC kW	PI kW	TC kW	PI kW	TC kW	PI kW	TC kW	PI kW
70%	-25	-25.4	67.32	36.39	63.32	33.65	59.04	33.08	56.64	32.47	54.50	32.07	49.96	30.87
	-19.8	-20	67.32	34.65	63.32	31.88	59.04	31.23	56.64	30.63	54.50	30.23	49.96	29.03
	-18.8	-19	67.86	34.28	63.32	31.54	59.04	30.90	56.64	30.30	54.50	29.90	49.96	28.69
	-16.7	-17	67.86	33.57	63.32	30.92	59.04	30.36	56.64	29.76	54.50	29.36	49.96	28.16
	-13.7	-15	67.86	32.91	63.32	30.30	59.04	29.78	56.64	29.18	54.50	28.78	49.96	27.58
	-11.8	-13	67.86	32.25	63.32	29.72	59.04	29.29	56.64	28.69	54.50	28.28	49.96	27.08
	-9.8	-11	67.86	31.63	63.32	29.14	59.04	28.75	56.64	28.15	54.50	27.75	49.96	26.54
	-9.5	-10	67.86	31.34	63.32	28.89	59.04	28.03	56.64	27.42	54.50	27.02	49.96	25.82
	-8.5	-9.1	67.86	31.05	63.32	28.65	59.04	27.09	56.64	26.49	54.50	26.09	49.96	24.88
	-7	-7.6	67.86	30.63	63.32	28.23	59.04	25.91	56.64	25.31	54.50	24.91	49.96	23.71
	-5	-5.6	67.86	29.68	63.32	27.40	59.04	25.21	56.64	24.61	54.50	24.21	49.96	23.00
	-3	-3.7	67.86	28.09	63.32	26.58	59.04	24.47	56.64	23.87	54.50	23.47	49.96	22.27
	0	-0.7	67.86	26.60	63.32	25.42	59.04	23.43	56.64	22.83	54.50	22.43	49.96	21.22
	3	2.2	67.86	25.10	63.32	24.03	59.04	22.00	56.64	21.40	54.50	21.00	49.96	19.79
	5	4.1	67.86	23.95	63.32	22.49	59.04	21.17	56.64	20.57	54.50	20.17	49.96	18.97
7	6	67.86	23.02	63.32	21.53	59.04	20.08	56.64	19.53	54.50	19.13	49.96	17.93	
9	7.9	67.86	22.02	63.32	20.70	59.04	19.41	56.64	18.81	54.50	18.41	49.96	17.21	
11	9.8	67.86	21.15	63.32	19.99	59.04	18.63	56.64	18.03	54.50	17.63	49.96	16.43	
13	11.8	67.86	20.37	63.32	19.17	59.04	17.74	56.64	17.13	54.50	16.73	49.96	15.53	
15	13.7	67.86	19.63	63.32	18.32	59.04	17.05	56.64	16.44	54.50	16.04	49.96	14.84	
60%	-25	-25.4	58.24	33.92	54.50	32.07	50.49	30.58	48.62	29.88	46.49	28.63	42.75	27.14
	-19.8	-20	58.24	32.12	54.50	30.59	50.49	29.42	48.62	28.58	46.49	27.29	42.75	25.74
	-18.8	-19	58.24	31.30	54.50	29.54	50.49	28.38	48.62	27.63	46.49	26.23	42.75	24.82
	-16.7	-17	58.24	30.31	54.50	28.62	50.49	27.51	48.62	26.56	46.49	25.24	42.75	23.83
	-13.7	-15	58.24	29.26	54.50	27.77	50.49	26.65	48.62	25.57	46.49	24.26	42.75	22.83
	-11.8	-13	58.24	28.23	54.50	26.74	50.49	25.62	48.62	24.69	46.49	23.23	42.75	21.82
	-9.8	-11	58.24	27.32	54.50	25.75	50.49	24.40	48.62	23.56	46.49	22.24	42.75	21.02
	-9.5	-10	58.24	26.34	54.50	24.72	50.49	23.40	48.62	22.55	46.49	21.27	42.75	19.87
	-8.5	-9.1	58.24	25.24	54.50	23.83	50.49	22.42	48.62	21.59	46.49	20.27	42.75	18.74
	-7	-7.6	58.24	24.31	54.50	22.81	50.49	21.64	48.62	20.86	46.49	19.49	42.75	17.92
	-5	-5.6	58.24	23.41	54.50	21.97	50.49	20.57	48.62	19.99	46.49	18.71	42.75	17.07
	-3	-3.7	58.24	22.59	54.50	21.10	50.49	19.65	48.62	19.19	46.49	17.88	42.75	16.47
	0	-0.7	58.24	21.68	54.50	20.26	50.49	18.77	48.62	18.27	46.49	17.00	42.75	16.15
	3	2.2	58.24	20.69	54.50	19.29	50.49	18.05	48.62	17.52	46.49	16.12	42.75	15.57
	5	4.1	58.24	19.64	54.50	18.47	50.49	17.39	48.62	16.74	46.49	15.76	42.75	15.23
7	6	58.24	18.74	54.50	17.68	50.49	16.57	48.62	16.06	46.49	15.68	42.75	14.94	
9	7.9	58.24	18.42	54.50	17.28	50.49	16.31	48.62	15.69	46.49	15.01	42.75	14.29	
11	9.8	58.24	18.14	54.50	17.03	50.49	15.89	48.62	15.31	46.49	14.70	42.75	14.02	
13	11.8	58.24	17.58	54.50	16.46	50.49	15.39	48.62	14.98	46.49	14.40	42.75	13.70	
15	13.7	58.24	17.37	54.50	16.13	50.49	14.94	48.62	14.62	46.49	14.02	42.75	13.31	
50%	-25	-25.4	48.62	28.08	45.42	26.55	42.21	25.32	40.34	24.74	38.74	24.12	35.53	22.47
	-19.8	-20	48.62	26.59	45.42	25.32	42.21	24.36	40.34	23.66	38.74	23.00	35.53	21.31
	-18.8	-19	48.62	25.91	45.42	24.45	42.21	23.50	40.34	22.87	38.74	22.12	35.53	20.55
	-16.7	-17	48.62	25.10	45.42	23.70	42.21	22.77	40.34	21.99	38.74	21.31	35.53	19.73
	-13.7	-15	48.62	24.23	45.42	22.99	42.21	22.06	40.34	21.17	38.74	20.49	35.53	18.90
	-11.8	-13	48.62	23.37	45.42	22.14	42.21	21.21	40.34	20.44	38.74	19.64	35.53	18.06
	-9.8	-11	48.62	22.62	45.42	21.32	42.21	20.20	40.34	19.51	38.74	18.82	35.53	17.40
	-9.5	-10	48.62	21.81	45.42	20.46	42.21	19.37	40.34	18.67	38.74	18.02	35.53	16.45
-8.5	-9.1	48.62	20.90	45.42	19.72	42.21	18.56	40.34	17.87	38.74	17.20	35.53	15.51	

MDV6 VRF 50Hz



	-7	-7.6	48.62	20.12	45.42	18.88	42.21	17.92	40.34	17.27	38.74	16.55	35.53	14.83
	-5	-5.6	48.62	19.38	45.42	18.19	42.21	17.03	40.34	16.55	38.74	15.90	35.53	14.13
	-3	-3.7	48.62	18.70	45.42	17.47	42.21	16.27	40.34	15.89	38.74	15.22	35.53	13.63
	0	-0.7	48.62	17.95	45.42	16.77	42.21	15.54	40.34	15.12	38.74	14.48	35.53	13.37
	3	2.2	48.62	17.13	45.42	15.97	42.21	14.94	40.34	14.51	38.74	13.76	35.53	13.30
	5	4.1	48.62	16.26	45.42	15.29	42.21	14.39	40.34	13.86	38.74	13.46	35.53	13.16
	7	6	48.62	15.51	45.42	14.64	42.21	13.72	40.34	13.30	38.74	13.25	35.53	12.78
	9	7.9	48.62	15.25	45.42	14.31	42.21	13.51	40.34	12.99	38.74	12.70	35.53	12.38
	11	9.8	48.62	15.02	45.42	14.10	42.21	13.15	40.34	12.67	38.74	12.47	35.53	12.15
	13	11.8	48.62	14.55	45.42	13.63	42.21	12.74	40.34	12.40	38.74	12.19	35.53	11.89
	15	13.7	48.62	14.38	45.42	13.35	42.21	12.37	40.34	12.10	38.74	11.86	35.53	11.57

Abbreviations:

CR: Combination ratio

TC: Total capacity (kW)

PI: Power input (compressor + outdoor fan motor) (kW)

Notes:

Shaded cells indicate rating condition.

Table 2-8.25: 30HP heating capacity

CR	Outdoor air temp.		Indoor air temp. °C DB											
			16		18		20		21		22		24	
	°C DB	°C WB	TC kW	PI kW	TC kW	PI kW	TC kW	PI kW	TC kW	PI kW	TC kW	PI kW	TC kW	PI kW
130%	-25	-25.4	74.11	23.35	73.81	23.75	72.27	24.70	72.03	25.40	71.97	26.10	71.55	26.51
	-19.8	-20	77.90	23.96	77.60	24.48	77.29	25.71	76.99	26.41	76.99	27.11	76.69	27.45
	-18.8	-19	78.50	24.40	78.20	24.80	77.90	25.95	77.90	26.65	77.60	27.35	77.29	27.60
	-16.7	-17	79.70	24.67	79.40	25.24	79.10	26.23	79.10	26.93	78.80	27.63	78.50	28.08
	-13.7	-15	80.90	24.96	80.60	25.62	80.30	26.70	80.30	27.39	80.00	28.09	79.70	28.47
	-11.8	-13	82.11	25.39	81.81	26.04	81.50	27.19	81.50	27.89	81.20	28.59	81.20	28.89
	-9.8	-11	83.31	25.77	83.01	26.50	82.71	27.48	82.71	28.17	82.71	28.87	82.41	28.93
	-9.5	-10	83.91	26.16	83.61	26.77	83.61	27.90	83.31	28.60	83.31	29.30	83.01	29.37
	-8.5	-9.1	84.51	26.51	84.21	27.15	83.91	28.21	83.91	28.90	83.91	29.60	83.61	29.70
	-7	-7.6	85.41	26.55	85.11	27.53	85.11	28.47	84.81	29.13	84.81	30.02	84.51	30.09
	-5	-5.6	92.03	27.71	91.73	28.30	91.43	29.36	91.43	30.25	91.13	30.21	90.83	30.45
	-3	-3.7	93.23	28.38	92.93	28.76	92.63	29.84	92.63	30.73	92.33	30.61	92.03	30.84
	0	-0.7	95.04	29.20	94.74	29.04	94.44	30.22	94.44	31.05	94.14	31.08	94.14	31.09
	3	2.2	104.99	30.88	103.76	30.92	103.46	31.78	103.16	32.38	103.16	32.71	102.86	32.97
	5	4.1	130.53	37.31	125.29	36.87	123.31	36.72	118.50	35.55	113.69	35.16	104.36	33.63
7	6	132.63	37.61	127.70	35.88	123.31	34.93	118.50	34.03	113.69	33.70	104.36	32.47	
9	7.9	132.63	35.77	127.70	34.16	123.31	33.87	118.50	33.40	113.69	32.85	104.36	31.73	
11	9.8	132.63	34.04	127.70	32.77	123.31	32.70	118.50	32.28	113.69	31.87	104.36	30.51	
13	11.8	132.63	32.38	127.70	31.80	123.31	31.79	118.50	31.73	113.69	31.18	104.36	29.96	
15	13.7	132.63	31.37	127.70	31.08	123.31	30.91	118.50	30.48	113.69	30.28	104.36	28.85	
120%	-25	-25.4	73.38	25.44	73.08	26.37	73.02	27.30	72.78	27.96	72.45	28.62	72.24	29.03
	-19.8	-20	77.81	26.13	77.51	27.01	77.21	27.79	77.21	28.45	76.90	29.11	76.60	29.61
	-18.8	-19	78.41	26.50	78.11	27.05	77.81	28.27	77.81	28.93	77.51	29.58	77.21	29.94
	-16.7	-17	79.62	26.90	79.32	27.44	79.02	28.65	79.02	29.31	78.71	29.97	78.71	30.05
	-13.7	-15	80.83	27.24	80.52	28.00	80.22	28.79	80.22	29.45	80.22	30.11	79.92	30.35
	-11.8	-13	82.03	27.65	81.73	28.30	81.56	29.16	81.43	29.82	81.43	30.48	81.13	30.69
	-9.8	-11	83.24	27.80	82.94	28.49	82.94	29.49	82.63	30.15	82.63	30.81	82.33	31.26
	-9.5	-10	83.84	28.12	83.54	28.70	83.54	29.69	83.24	30.35	83.24	31.01	82.94	31.66
	-8.5	-9.1	84.44	28.39	84.14	29.07	84.14	30.03	83.84	30.69	83.84	31.35	83.54	31.69
	-7	-7.6	85.35	28.90	85.05	29.60	85.05	30.36	84.75	31.02	84.75	31.68	84.44	32.05
	-5	-5.6	91.98	29.13	91.68	29.83	91.38	30.68	91.38	31.34	91.38	32.00	91.08	32.59
	-3	-3.7	93.19	29.65	92.89	30.32	92.59	31.08	92.59	31.73	92.29	32.39	92.29	32.76
	0	-0.7	95.00	30.02	94.70	30.74	94.40	31.34	94.40	32.00	94.40	32.66	94.10	32.99
	3	2.2	103.75	31.84	103.75	32.68	103.44	32.94	103.14	33.60	103.14	34.26	96.51	32.66
	5	4.1	130.59	35.69	122.75	35.32	114.00	34.74	109.48	34.05	105.25	33.67	96.51	31.67
7	6	131.49	35.43	122.75	33.84	114.00	32.99	109.48	32.40	105.25	32.21	96.51	30.89	
9	7.9	131.49	33.90	122.75	32.33	114.00	31.98	109.48	31.34	105.25	31.29	96.51	29.95	
11	9.8	131.49	32.79	122.75	31.65	114.00	30.89	109.48	30.42	105.25	30.16	96.51	28.84	
13	11.8	131.49	32.00	122.75	30.85	114.00	30.03	109.48	29.95	105.25	29.61	96.51	28.27	
15	13.7	131.49	31.29	122.75	29.93	114.00	29.19	109.48	28.85	105.25	28.61	96.51	27.23	
110%	-25	-25.4	74.29	26.19	73.95	26.80	73.58	27.41	73.69	26.99	73.42	27.51	73.39	28.23
	-19.8	-20	77.51	26.57	77.21	27.17	76.90	27.78	76.90	27.36	76.60	27.88	76.60	28.58
	-18.8	-19	78.11	26.97	77.81	27.57	77.51	28.18	77.51	27.40	77.21	28.18	77.21	28.67
	-16.7	-17	79.32	27.36	79.02	27.96	78.71	28.57	78.71	27.93	78.71	28.52	78.41	29.05
	-13.7	-15	80.52	27.60	80.22	28.21	79.92	28.82	79.92	28.10	79.92	28.65	79.62	29.35
-11.8	-13	81.73	28.01	81.43	28.62	81.43	29.23	81.13	28.39	81.13	28.99	80.83	29.69	

-9.8	-11	82.94	28.01	82.63	28.62	82.63	29.23	82.33	28.91	82.33	29.34	82.03	30.08
-9.5	-10	83.54	28.32	83.54	28.93	83.24	29.54	82.94	29.01	82.94	29.68	82.63	30.38
-8.5	-9.1	84.14	28.63	83.84	29.24	83.84	29.85	83.54	29.29	83.54	29.98	83.24	30.73
-7	-7.6	85.05	28.94	84.75	29.55	84.75	30.15	84.44	29.72	84.44	30.33	84.14	30.81
-5	-5.6	91.68	29.32	91.38	29.93	91.08	30.54	91.08	30.01	91.08	30.50	88.37	30.48
-3	-3.7	92.89	29.53	92.59	30.14	92.29	30.75	92.29	30.26	92.29	30.90	88.37	29.96
0	-0.7	94.70	30.25	94.40	30.85	94.40	31.46	94.10	30.51	94.10	31.18	88.37	29.53
3	2.2	103.44	31.60	103.44	32.21	103.14	32.82	100.43	31.73	96.51	31.41	88.37	29.28
5	4.1	120.63	34.48	112.49	34.39	104.65	32.07	100.43	31.16	96.51	30.61	88.37	29.17
7	6	120.63	33.21	112.49	32.39	104.65	30.45	100.43	29.63	96.51	29.19	88.37	28.44
9	7.9	120.63	31.70	112.49	30.65	104.65	29.36	100.43	28.89	96.51	28.58	88.37	27.95
11	9.8	120.63	30.57	112.49	29.52	104.65	28.52	100.43	27.85	96.51	27.65	88.37	27.02
13	11.8	120.63	29.67	112.49	28.60	104.65	27.61	100.43	27.04	96.51	26.71	88.37	26.10
15	13.7	120.63	28.82	112.49	27.66	104.65	26.69	100.43	26.11	96.51	25.80	88.37	25.18

Abbreviations:

CR: Combination ratio

TC: Total capacity (kW)

PI: Power input (compressor + outdoor fan motor) (kW)

Notes: Shaded cells indicate rating condition.

Table 2-8.25: 30HP heating capacity (continued)

CR	Outdoor air temp.		Indoor air temp. °C DB											
			16		18		20		21		22		24	
	°C DB	°C WB	TC kW	PI kW	TC kW	PI kW	TC kW	PI kW	TC kW	PI kW	TC kW	PI kW	TC kW	PI kW
100%	-25	-25.4	74.36	32.72	74.05	33.04	73.75	33.23	73.75	33.60	73.75	33.80	73.45	34.24
	-19.8	-20	77.81	32.72	77.51	33.08	77.21	33.44	77.21	33.64	77.21	33.84	76.90	34.00
	-18.8	-19	79.02	32.80	78.71	33.16	78.41	33.52	78.41	33.68	78.41	33.88	78.11	33.73
	-16.7	-17	80.22	32.84	79.92	33.20	79.92	33.56	79.62	33.76	79.62	33.96	79.32	33.56
	-13.7	-15	81.43	32.92	81.13	33.24	81.13	33.64	80.83	33.80	80.83	34.00	80.52	33.15
	-11.8	-13	82.63	32.96	82.33	33.32	82.33	33.68	82.03	33.88	82.03	34.04	80.52	32.79
	-9.8	-11	83.24	33.00	83.24	33.36	82.94	33.72	82.94	33.88	82.63	34.08	80.52	32.75
	-9.5	-10	83.84	33.04	83.54	33.36	83.54	33.80	83.24	33.92	83.24	34.12	80.52	32.47
	-8.5	-9.1	84.75	33.08	84.75	33.40	84.44	33.91	84.14	33.96	84.14	34.16	80.52	31.97
	-7	-7.6	91.38	33.12	91.08	33.41	91.08	34.60	90.78	35.19	87.76	33.48	80.52	31.86
	-5	-5.6	92.59	33.16	92.29	33.43	92.29	33.79	91.38	34.20	87.76	32.48	80.52	30.97
	-3	-3.7	94.40	33.20	94.10	33.45	94.10	32.68	91.38	32.22	87.76	31.45	80.52	29.94
	0	-0.7	96.81	33.24	102.24	33.47	95.00	31.77	91.38	30.76	87.76	29.91	80.52	28.63
	3	2.2	103.14	32.57	102.24	32.64	95.00	30.86	91.38	29.26	87.76	28.12	80.52	27.23
	5	4.1	109.48	32.06	102.24	31.04	95.00	29.40	91.38	27.95	87.76	26.98	80.52	26.02
7	6	109.48	31.66	102.24	29.45	95.00	27.53	91.38	26.46	87.76	25.89	80.52	24.88	
9	7.9	109.48	29.85	102.24	27.89	95.00	26.76	91.38	25.80	87.76	25.12	80.52	24.07	
11	9.8	109.48	27.93	102.24	26.18	95.00	25.88	91.38	24.76	87.76	24.20	80.52	23.06	
13	11.8	109.48	26.18	102.24	25.53	95.00	24.88	91.38	23.88	87.76	23.35	80.52	22.28	
15	13.7	109.48	24.90	102.24	24.45	95.00	23.96	91.38	23.04	87.76	22.51	80.52	21.40	
90%	-25	-25.4	73.78	32.69	73.38	32.99	73.14	33.37	73.08	33.80	73.08	33.92	72.38	31.79
	-19.8	-20	76.90	33.24	76.60	33.56	76.30	33.92	76.30	34.12	76.30	34.32	72.38	31.12
	-18.8	-19	77.51	33.28	77.21	33.60	76.90	33.96	76.90	34.16	76.90	34.20	72.38	30.80
	-16.7	-17	78.71	33.32	78.41	33.64	78.41	34.00	78.11	34.20	78.11	33.52	72.38	30.17
	-13.7	-15	79.92	33.36	79.62	33.72	79.62	34.08	79.32	34.24	79.02	32.84	72.38	29.57
	-11.8	-13	81.13	33.44	80.83	33.76	80.83	34.12	80.52	33.80	79.02	32.16	72.38	29.01
	-9.8	-11	82.33	33.48	82.33	33.84	82.03	34.16	82.03	33.12	79.02	31.56	72.38	28.45
	-9.5	-10	82.94	33.52	82.94	33.84	82.63	34.20	82.33	32.80	79.02	31.24	72.38	28.17
	-8.5	-9.1	83.54	33.56	83.24	33.88	83.24	34.12	82.33	32.52	79.02	30.96	72.38	27.93
	-7	-7.6	84.44	33.60	84.44	33.42	84.14	33.64	82.33	32.08	79.02	30.53	72.38	27.53
	-5	-5.6	91.08	33.65	90.78	31.98	85.65	32.23	82.33	31.00	79.02	29.57	72.38	26.73
	-3	-3.7	92.29	33.70	91.98	30.57	85.65	30.63	82.33	29.86	79.02	28.63	72.38	26.05
	0	-0.7	94.10	33.75	91.98	29.03	85.65	29.32	82.33	28.43	79.02	27.22	72.38	25.38
	3	2.2	98.62	33.80	91.98	27.50	85.65	27.67	82.33	27.35	79.02	26.00	72.38	24.52
	5	4.1	98.62	32.96	91.98	26.15	85.65	26.41	82.33	25.95	79.02	24.79	72.38	23.54
7	6	98.62	28.65	91.98	25.67	85.65	24.70	82.33	23.74	79.02	22.82	72.38	20.95	
9	7.9	98.62	26.89	91.98	25.18	85.65	23.46	82.33	22.62	79.02	21.79	72.38	20.15	
11	9.8	98.62	25.34	91.98	23.82	85.65	22.35	82.33	21.59	79.02	20.87	72.38	19.43	
13	11.8	98.62	23.94	91.98	22.62	85.65	21.35	82.33	20.71	79.02	20.07	72.38	18.79	
15	13.7	98.62	22.94	91.98	21.79	85.65	20.63	82.33	20.07	79.02	19.51	72.38	18.36	
80%	-25	-25.4	73.68	34.66	73.37	35.09	73.72	34.03	72.98	32.42	70.27	31.03	64.24	28.13
	-19.8	-20	76.60	33.37	76.30	33.73	76.00	32.59	72.98	31.09	70.27	29.63	64.24	26.75
	-18.8	-19	77.21	33.41	76.90	33.73	76.00	32.27	72.98	30.77	70.27	29.32	64.24	26.48
	-16.7	-17	78.41	33.45	78.11	33.81	76.00	31.60	72.98	30.14	70.27	28.72	64.24	25.93
	-13.7	-15	79.62	33.53	79.32	33.85	76.00	30.97	72.98	29.55	70.27	28.17	64.24	25.45
-11.8	-13	80.83	33.57	80.52	33.22	76.00	30.34	72.98	28.96	70.27	27.62	64.24	24.98	

MDV6 VRF 50Hz



	-9.8	-11	82.03	33.61	81.73	32.55	76.00	29.79	72.98	28.41	70.27	27.11	64.24	24.51
	-9.5	-10	82.63	33.65	81.73	32.23	76.00	29.47	72.98	28.13	70.27	26.83	64.24	24.27
	-8.5	-9.1	83.24	33.69	81.73	31.96	76.00	29.24	72.98	27.90	70.27	26.60	64.24	24.08
	-7	-7.6	84.14	33.73	81.73	31.48	76.00	28.84	72.98	27.54	70.27	26.24	64.24	23.76
	-5	-5.6	87.76	33.06	81.73	30.46	76.00	27.94	72.98	26.68	70.27	25.49	64.24	23.09
	-3	-3.7	87.76	34.20	81.73	29.35	76.00	26.75	72.98	25.67	70.27	24.57	64.24	22.44
	0	-0.7	87.76	33.76	81.73	28.00	76.00	25.82	72.98	24.91	70.27	23.83	64.24	21.92
	3	2.2	87.76	31.21	81.73	26.42	76.00	24.36	72.98	24.03	70.27	22.93	64.24	21.06
	5	4.1	87.76	28.53	81.73	24.96	76.00	23.24	72.98	23.05	70.27	21.85	64.24	20.61
	7	6	87.76	25.02	81.73	23.37	76.00	21.71	72.98	20.88	70.27	20.10	64.24	18.52
	9	7.9	87.76	23.72	81.73	22.26	76.00	20.80	72.98	20.10	70.27	19.35	64.24	17.97
	11	9.8	87.76	22.54	81.73	21.24	76.00	19.98	72.98	19.35	70.27	18.72	64.24	17.49
	13	11.8	87.76	21.51	81.73	20.37	76.00	19.27	72.98	18.72	70.27	18.16	64.24	17.06
	15	13.7	87.76	20.77	81.73	19.74	76.00	18.76	72.98	18.28	70.27	17.77	64.24	16.79

Abbreviations:

CR: Combination ratio

TC: Total capacity (kW)

PI: Power input (compressor + outdoor fan motor) (kW)

Notes:

Shaded cells indicate rating condition.

Table 2-8.25: 30HP heating capacity (continued)

CR	Outdoor air temp.		Indoor air temp. °C DB											
			16		18		20		21		22		24	
	°C DB	°C WB	TC kW	PI kW	TC kW	PI kW	TC kW	PI kW	TC kW	PI kW	TC kW	PI kW	TC kW	PI kW
70%	-25	-25.4	76.00	35.07	71.48	32.44	66.65	31.88	63.94	31.30	61.52	30.91	56.40	29.75
	-19.8	-20	76.00	33.40	71.48	30.72	66.65	30.11	63.94	29.53	61.52	29.14	56.40	27.98
	-18.8	-19	76.60	33.04	71.48	30.41	66.65	29.79	63.94	29.21	61.52	28.82	56.40	27.66
	-16.7	-17	76.60	32.36	71.48	29.81	66.65	29.27	63.94	28.69	61.52	28.30	56.40	27.14
	-13.7	-15	76.60	31.72	71.48	29.21	66.65	28.71	63.94	28.13	61.52	27.74	56.40	26.58
	-11.8	-13	76.60	31.08	71.48	28.65	66.65	28.23	63.94	27.65	61.52	27.26	56.40	26.10
	-9.8	-11	76.60	30.49	71.48	28.09	66.65	27.71	63.94	27.13	61.52	26.74	56.40	25.58
	-9.5	-10	76.60	30.21	71.48	27.85	66.65	27.01	63.94	26.43	61.52	26.05	56.40	24.89
	-8.5	-9.1	76.60	29.93	71.48	27.61	66.65	26.11	63.94	25.53	61.52	25.14	56.40	23.98
	-7	-7.6	76.60	29.53	71.48	27.21	66.65	24.98	63.94	24.40	61.52	24.01	56.40	22.85
	-5	-5.6	76.60	28.61	71.48	26.42	66.65	24.30	63.94	23.72	61.52	23.33	56.40	22.17
	-3	-3.7	76.60	27.07	71.48	25.62	66.65	23.59	63.94	23.01	61.52	22.62	56.40	21.46
	0	-0.7	76.60	25.64	71.48	24.50	66.65	22.58	63.94	22.00	61.52	21.62	56.40	20.46
	3	2.2	76.60	24.19	71.48	23.16	66.65	21.21	63.94	20.63	61.52	20.24	56.40	19.08
	5	4.1	76.60	23.08	71.48	21.68	66.65	20.41	63.94	19.83	61.52	19.44	56.40	18.28
7	6	76.60	22.19	71.48	20.75	66.65	19.35	63.94	18.83	61.52	18.44	56.40	17.28	
9	7.9	76.60	21.23	71.48	19.95	66.65	18.71	63.94	18.13	61.52	17.75	56.40	16.59	
11	9.8	76.60	20.39	71.48	19.27	66.65	17.96	63.94	17.38	61.52	16.99	56.40	15.83	
13	11.8	76.60	19.63	71.48	18.48	66.65	17.10	63.94	16.52	61.52	16.13	56.40	14.97	
15	13.7	76.60	18.92	71.48	17.65	66.65	16.43	63.94	15.85	61.52	15.46	56.40	14.30	
60%	-25	-25.4	65.75	32.69	61.52	30.91	57.00	29.48	54.89	28.80	52.48	27.60	48.25	26.16
	-19.8	-20	65.75	30.96	61.52	29.49	57.00	28.36	54.89	27.55	52.48	26.31	48.25	24.81
	-18.8	-19	65.75	30.17	61.52	28.47	57.00	27.36	54.89	26.63	52.48	25.28	48.25	23.92
	-16.7	-17	65.75	29.22	61.52	27.59	57.00	26.51	54.89	25.60	52.48	24.33	48.25	22.97
	-13.7	-15	65.75	28.21	61.52	26.77	57.00	25.69	54.89	24.64	52.48	23.38	48.25	22.01
	-11.8	-13	65.75	27.21	61.52	25.78	57.00	24.70	54.89	23.80	52.48	22.39	48.25	21.03
	-9.8	-11	65.75	26.33	61.52	24.82	57.00	23.52	54.89	22.71	52.48	21.44	48.25	20.26
	-9.5	-10	65.75	25.39	61.52	23.82	57.00	22.55	54.89	21.74	52.48	20.50	48.25	19.15
	-8.5	-9.1	65.75	24.33	61.52	22.97	57.00	21.61	54.89	20.81	52.48	19.54	48.25	18.06
	-7	-7.6	65.75	23.43	61.52	21.99	57.00	20.86	54.89	20.11	52.48	18.79	48.25	17.27
	-5	-5.6	65.75	22.56	61.52	21.18	57.00	19.82	54.89	19.27	52.48	18.04	48.25	16.45
	-3	-3.7	65.75	21.78	61.52	20.34	57.00	18.94	54.89	18.50	52.48	17.24	48.25	15.87
	0	-0.7	65.75	20.90	61.52	19.53	57.00	18.09	54.89	17.61	52.48	16.38	48.25	15.57
	3	2.2	65.75	19.95	61.52	18.59	57.00	17.40	54.89	16.89	52.48	15.54	48.25	15.00
	5	4.1	65.75	18.93	61.52	17.80	57.00	16.76	54.89	16.13	52.48	15.19	48.25	14.68
7	6	65.75	18.06	61.52	17.04	57.00	15.97	54.89	15.48	52.48	15.11	48.25	14.41	
9	7.9	65.75	17.75	61.52	16.66	57.00	15.72	54.89	15.12	52.48	14.47	48.25	13.77	
11	9.8	65.75	17.49	61.52	16.42	57.00	15.32	54.89	14.76	52.48	14.17	48.25	13.51	
13	11.8	65.75	16.94	61.52	15.87	57.00	14.84	54.89	14.44	52.48	13.88	48.25	13.21	
15	13.7	65.75	16.74	61.52	15.55	57.00	14.40	54.89	14.09	52.48	13.52	48.25	12.83	
50%	-25	-25.4	54.89	27.07	51.27	25.59	47.65	24.40	45.54	23.85	43.73	23.25	40.11	21.66
	-19.8	-20	54.89	25.63	51.27	24.41	47.65	23.48	45.54	22.81	43.73	22.17	40.11	20.54
	-18.8	-19	54.89	24.97	51.27	23.57	47.65	22.65	45.54	22.05	43.73	21.33	40.11	19.81
	-16.7	-17	54.89	24.19	51.27	22.84	47.65	21.95	45.54	21.19	43.73	20.54	40.11	19.01
	-13.7	-15	54.89	23.35	51.27	22.16	47.65	21.26	45.54	20.40	43.73	19.75	40.11	18.22

-11.8	-13	54.89	22.53	51.27	21.34	47.65	20.45	45.54	19.70	43.73	18.93	40.11	17.41
-9.8	-11	54.89	21.80	51.27	20.55	47.65	19.47	45.54	18.80	43.73	18.14	40.11	16.77
-9.5	-10	54.89	21.02	51.27	19.72	47.65	18.67	45.54	18.00	43.73	17.37	40.11	15.86
-8.5	-9.1	54.89	20.14	51.27	19.01	47.65	17.89	45.54	17.23	43.73	16.58	40.11	14.95
-7	-7.6	54.89	19.40	51.27	18.20	47.65	17.27	45.54	16.65	43.73	15.95	40.11	14.30
-5	-5.6	54.89	18.68	51.27	17.53	47.65	16.41	45.54	15.95	43.73	15.33	40.11	13.62
-3	-3.7	54.89	18.03	51.27	16.84	47.65	15.68	45.54	15.32	43.73	14.67	40.11	13.14
0	-0.7	54.89	17.30	51.27	16.17	47.65	14.98	45.54	14.58	43.73	13.96	40.11	12.89
3	2.2	54.89	16.51	51.27	15.39	47.65	14.40	45.54	13.98	43.73	13.26	40.11	12.82
5	4.1	54.89	15.67	51.27	14.74	47.65	13.87	45.54	13.36	43.73	12.97	40.11	12.69
7	6	54.89	14.95	51.27	14.11	47.65	13.22	45.54	12.82	43.73	12.77	40.11	12.32
9	7.9	54.89	14.70	51.27	13.79	47.65	13.02	45.54	12.52	43.73	12.24	40.11	11.93
11	9.8	54.89	14.48	51.27	13.59	47.65	12.68	45.54	12.22	43.73	12.02	40.11	11.71
13	11.8	54.89	14.03	51.27	13.14	47.65	12.28	45.54	11.95	43.73	11.75	40.11	11.46
15	13.7	54.89	13.86	51.27	12.87	47.65	11.92	45.54	11.67	43.73	11.43	40.11	11.15

Abbreviations:

CR: Combination ratio

TC: Total capacity (kW)

PI: Power input (compressor + outdoor fan motor) (kW)

Notes: Shaded cells indicate rating condition.

Table 2-8.26: 32HP heating capacity

CR	Outdoor air temp.		Indoor air temp. °C DB											
			16		18		20		21		22		24	
	°C DB	°C WB	TC kW	PI kW	TC kW	PI kW	TC kW	PI kW	TC kW	PI kW	TC kW	PI kW	TC kW	PI kW
130%	-25	-25.4	78.01	25.72	77.69	26.17	76.08	27.21	75.82	27.98	75.76	28.75	75.32	29.20
	-19.8	-20	82.00	26.40	81.68	26.96	81.36	28.32	81.05	29.09	81.05	29.86	80.73	30.24
	-18.8	-19	82.63	26.88	82.31	27.32	82.00	28.59	82.00	29.35	81.68	30.12	81.36	30.40
	-16.7	-17	83.90	27.18	83.58	27.80	83.26	28.89	83.26	29.66	82.95	30.43	82.63	30.93
	-13.7	-15	85.16	27.49	84.84	28.22	84.53	29.41	84.53	30.18	84.21	30.94	83.90	31.36
	-11.8	-13	86.43	27.96	86.11	28.68	85.79	29.95	85.79	30.72	85.48	31.49	85.48	31.83
	-9.8	-11	87.69	28.39	87.38	29.19	87.06	30.26	87.06	31.03	87.06	31.80	86.74	31.87
	-9.5	-10	88.33	28.82	88.01	29.49	88.01	30.73	87.69	31.50	87.69	32.27	87.38	32.35
	-8.5	-9.1	88.96	29.20	88.64	29.91	88.33	31.07	88.33	31.84	88.33	32.61	88.01	32.72
	-7	-7.6	89.91	29.24	89.59	30.33	89.59	31.36	89.28	32.09	89.28	33.07	88.96	33.15
	-5	-5.6	96.88	30.52	96.56	31.18	96.24	32.34	96.24	33.32	95.93	33.28	95.61	33.54
	-3	-3.7	98.14	31.26	97.82	31.68	97.51	32.87	97.51	33.85	97.19	33.72	96.88	33.97
	0	-0.7	100.04	32.17	99.72	31.99	99.41	33.29	99.41	34.21	99.09	34.23	99.09	34.24
	3	2.2	110.52	34.02	109.22	34.06	108.91	35.01	108.59	35.66	108.59	36.03	108.27	36.32
	5	4.1	137.40	41.10	131.89	40.62	129.80	40.45	124.73	39.16	119.67	38.73	109.86	37.05
	7	6	139.61	41.43	134.42	39.53	129.80	38.47	124.73	37.48	119.67	37.12	109.86	35.77
9	7.9	139.61	39.41	134.42	37.63	129.80	37.30	124.73	36.79	119.67	36.18	109.86	34.95	
11	9.8	139.61	37.50	134.42	36.09	129.80	36.02	124.73	35.56	119.67	35.11	109.86	33.60	
13	11.8	139.61	35.67	134.42	35.03	129.80	35.02	124.73	34.96	119.67	34.34	109.86	33.00	
15	13.7	139.61	34.56	134.42	34.24	129.80	34.05	124.73	33.58	119.67	33.36	109.86	31.78	
120%	-25	-25.4	77.25	28.02	76.93	29.05	76.86	30.07	76.61	30.80	76.27	31.52	76.04	31.97
	-19.8	-20	81.90	28.79	81.59	29.75	81.27	30.62	81.27	31.34	80.95	32.07	80.63	32.62
	-18.8	-19	82.54	29.19	82.22	29.80	81.90	31.14	81.90	31.86	81.59	32.59	81.27	32.98
	-16.7	-17	83.81	29.63	83.49	30.23	83.17	31.56	83.17	32.28	82.86	33.01	82.86	33.10
	-13.7	-15	85.08	30.01	84.76	30.84	84.44	31.71	84.44	32.44	84.44	33.16	84.13	33.43
	-11.8	-13	86.35	30.46	86.03	31.17	85.85	32.12	85.71	32.85	85.71	33.57	85.40	33.81
	-9.8	-11	87.62	30.62	87.30	31.38	87.30	32.48	86.98	33.21	86.98	33.94	86.67	34.44
	-9.5	-10	88.25	30.98	87.94	31.62	87.94	32.71	87.62	33.44	87.62	34.16	87.30	34.87
	-8.5	-9.1	88.89	31.27	88.57	32.02	88.57	33.08	88.25	33.80	88.25	34.53	87.94	34.90
	-7	-7.6	89.84	31.84	89.52	32.60	89.52	33.44	89.21	34.17	89.21	34.90	88.89	35.30
	-5	-5.6	96.83	32.09	96.51	32.86	96.19	33.79	96.19	34.52	96.19	35.25	95.87	35.90
	-3	-3.7	98.10	32.66	97.78	33.39	97.46	34.23	97.46	34.96	97.14	35.68	97.14	36.09
	0	-0.7	100.00	33.07	99.68	33.86	99.37	34.52	99.37	35.25	99.37	35.97	99.05	36.34
	3	2.2	109.21	35.07	109.21	36.00	108.89	36.28	108.57	37.01	108.57	37.73	101.59	35.97
	5	4.1	137.46	39.31	129.21	38.91	120.00	38.27	115.24	37.50	110.79	37.09	101.59	34.88
	7	6	138.41	39.03	129.21	37.28	120.00	36.34	115.24	35.69	110.79	35.49	101.59	34.03
9	7.9	138.41	37.34	129.21	35.62	120.00	35.23	115.24	34.52	110.79	34.47	101.59	32.99	
11	9.8	138.41	36.12	129.21	34.87	120.00	34.02	115.24	33.51	110.79	33.22	101.59	31.77	
13	11.8	138.41	35.25	129.21	33.98	120.00	33.08	115.24	32.99	110.79	32.61	101.59	31.14	
15	13.7	138.41	34.47	129.21	32.97	120.00	32.16	115.24	31.77	110.79	31.51	101.59	29.99	
110%	-25	-25.4	78.20	28.85	77.84	29.52	77.46	30.19	77.57	29.73	77.29	30.31	77.25	31.10
	-19.8	-20	81.59	29.26	81.27	29.93	80.95	30.60	80.95	30.14	80.63	30.71	80.63	31.48
	-18.8	-19	82.22	29.70	81.90	30.37	81.59	31.04	81.59	30.19	81.27	31.04	81.27	31.58
	-16.7	-17	83.49	30.13	83.17	30.80	82.86	31.47	82.86	30.77	82.86	31.42	82.54	31.99
-13.7	-15	84.76	30.40	84.44	31.07	84.13	31.74	84.13	30.96	84.13	31.56	83.81	32.33	

	-11.8	-13	86.03	30.85	85.71	31.52	85.71	32.19	85.40	31.28	85.40	31.93	85.08	32.71
	-9.8	-11	87.30	30.86	86.98	31.53	86.98	32.20	86.67	31.85	86.67	32.31	86.35	33.13
	-9.5	-10	87.94	31.20	87.94	31.87	87.62	32.54	87.30	31.96	87.30	32.69	86.98	33.47
	-8.5	-9.1	88.57	31.53	88.25	32.21	88.25	32.88	87.94	32.26	87.94	33.03	87.62	33.85
	-7	-7.6	89.52	31.87	89.21	32.55	89.21	33.22	88.89	32.73	88.89	33.41	88.57	33.94
	-5	-5.6	96.51	32.30	96.19	32.97	95.87	33.64	95.87	33.05	95.87	33.60	93.02	33.58
	-3	-3.7	97.78	32.53	97.46	33.20	97.14	33.87	97.14	33.33	97.14	34.04	93.02	33.00
	0	-0.7	99.68	33.32	99.37	33.99	99.37	34.66	99.05	33.61	99.05	34.34	93.02	32.53
	3	2.2	108.89	34.81	108.89	35.48	108.57	36.15	105.71	34.95	101.59	34.60	93.02	32.26
	5	4.1	126.98	37.99	118.41	37.88	110.16	35.32	105.71	34.33	101.59	33.72	93.02	32.13
	7	6	126.98	36.58	118.41	35.68	110.16	33.54	105.71	32.64	101.59	32.15	93.02	31.32
	9	7.9	126.98	34.92	118.41	33.76	110.16	32.35	105.71	31.83	101.59	31.48	93.02	30.79
	11	9.8	126.98	33.67	118.41	32.52	110.16	31.42	105.71	30.68	101.59	30.46	93.02	29.77
	13	11.8	126.98	32.68	118.41	31.51	110.16	30.41	105.71	29.78	101.59	29.42	93.02	28.75
	15	13.7	126.98	31.75	118.41	30.46	110.16	29.41	105.71	28.76	101.59	28.42	93.02	27.73

Abbreviations:

CR: Combination ratio

TC: Total capacity (kW)

PI: Power input (compressor + outdoor fan motor) (kW)

Notes:

Shaded cells indicate rating condition.

Table 2-8.26: 32HP heating capacity (continued)

CR	Outdoor air temp.		Indoor air temp. °C DB											
			16		18		20		21		22		24	
	°C DB	°C WB	TC kW	PI kW	TC kW	PI kW	TC kW	PI kW	TC kW	PI kW	TC kW	PI kW	TC kW	PI kW
100%	-25	-25.4	78.27	36.04	77.95	36.39	77.63	36.61	77.63	37.01	77.63	37.23	77.32	37.71
	-19.8	-20	81.90	36.04	81.59	36.44	81.27	36.83	81.27	37.05	81.27	37.27	80.95	37.45
	-18.8	-19	83.17	36.13	82.86	36.53	82.54	36.92	82.54	37.10	82.54	37.32	82.22	37.15
	-16.7	-17	84.44	36.17	84.13	36.57	84.13	36.97	83.81	37.19	83.81	37.40	83.49	36.97
	-13.7	-15	85.71	36.26	85.40	36.61	85.40	37.05	85.08	37.23	85.08	37.45	84.76	36.52
	-11.8	-13	86.98	36.31	86.67	36.70	86.67	37.10	86.35	37.32	86.35	37.49	84.76	36.12
	-9.8	-11	87.62	36.35	87.62	36.75	87.30	37.14	87.30	37.32	86.98	37.54	84.76	36.07
	-9.5	-10	88.25	36.39	87.94	36.75	87.94	37.23	87.62	37.36	87.62	37.58	84.76	35.77
	-8.5	-9.1	89.21	36.44	89.21	36.79	88.89	37.35	88.57	37.40	88.57	37.62	84.76	35.22
	-7	-7.6	96.19	36.48	95.87	36.80	95.87	38.11	95.56	38.77	92.38	36.88	84.76	35.09
	-5	-5.6	97.46	36.53	97.14	36.83	97.14	37.22	96.19	37.67	92.38	35.78	84.76	34.11
	-3	-3.7	99.37	36.57	99.05	36.85	99.05	36.00	96.19	35.49	92.38	34.64	84.76	32.98
	0	-0.7	101.90	36.61	107.62	36.87	100.00	35.00	96.19	33.88	92.38	32.95	84.76	31.54
	3	2.2	108.57	35.88	107.62	35.95	100.00	33.99	96.19	32.24	92.38	30.98	84.76	29.99
	5	4.1	115.24	35.31	107.62	34.20	100.00	32.39	96.19	30.79	92.38	29.72	84.76	28.66
7	6	115.24	34.87	107.62	32.44	100.00	30.33	96.19	29.14	92.38	28.52	84.76	27.40	
9	7.9	115.24	32.88	107.62	30.72	100.00	29.48	96.19	28.43	92.38	27.67	84.76	26.52	
11	9.8	115.24	30.77	107.62	28.83	100.00	28.50	96.19	27.28	92.38	26.66	84.76	25.41	
13	11.8	115.24	28.83	107.62	28.12	100.00	27.40	96.19	26.31	92.38	25.72	84.76	24.54	
15	13.7	115.24	27.43	107.62	26.93	100.00	26.39	96.19	25.38	92.38	24.80	84.76	23.58	
90%	-25	-25.4	77.67	36.01	77.24	36.34	76.99	36.76	76.93	37.23	76.93	37.36	76.19	35.02
	-19.8	-20	80.95	36.61	80.63	36.97	80.32	37.36	80.32	37.58	80.32	37.80	76.19	34.28
	-18.8	-19	81.59	36.66	81.27	37.01	80.95	37.40	80.95	37.62	80.95	37.67	76.19	33.93
	-16.7	-17	82.86	36.70	82.54	37.05	82.54	37.45	82.22	37.67	82.22	36.92	76.19	33.23
	-13.7	-15	84.13	36.75	83.81	37.14	83.81	37.54	83.49	37.71	83.17	36.17	76.19	32.57
	-11.8	-13	85.40	36.83	85.08	37.19	85.08	37.58	84.76	37.23	83.17	35.43	76.19	31.95
	-9.8	-11	86.67	36.88	86.67	37.27	86.35	37.62	86.35	36.48	83.17	34.77	76.19	31.34
	-9.5	-10	87.30	36.92	87.30	37.27	86.98	37.67	86.67	36.13	83.17	34.42	76.19	31.03
	-8.5	-9.1	87.94	36.97	87.62	37.32	87.62	37.58	86.67	35.82	83.17	34.11	76.19	30.77
	-7	-7.6	88.89	37.01	88.89	36.82	88.57	37.05	86.67	35.34	83.17	33.62	76.19	30.33
	-5	-5.6	95.87	37.07	95.56	35.22	90.16	35.51	86.67	34.15	83.17	32.57	76.19	29.45
	-3	-3.7	97.14	37.12	96.83	33.67	90.16	33.74	86.67	32.89	83.17	31.54	76.19	28.70
	0	-0.7	99.05	37.18	96.83	31.98	90.16	32.30	86.67	31.32	83.17	29.99	76.19	27.96
	3	2.2	103.81	37.23	96.83	30.30	90.16	30.48	86.67	30.13	83.17	28.64	76.19	27.01
	5	4.1	103.81	36.31	96.83	28.80	90.16	29.09	86.67	28.58	83.17	27.31	76.19	25.93
7	6	103.81	31.56	96.83	28.27	90.16	27.21	86.67	26.15	83.17	25.14	76.19	23.08	
9	7.9	103.81	29.62	96.83	27.73	90.16	25.84	86.67	24.92	83.17	24.00	76.19	22.20	
11	9.8	103.81	27.91	96.83	26.24	90.16	24.61	86.67	23.78	83.17	22.99	76.19	21.41	
13	11.8	103.81	26.37	96.83	24.92	90.16	23.52	86.67	22.81	83.17	22.11	76.19	20.70	
15	13.7	103.81	25.27	96.83	24.00	90.16	22.72	86.67	22.11	83.17	21.49	76.19	20.22	
80%	-25	-25.4	77.55	38.18	77.24	38.65	77.60	37.49	76.83	35.71	73.97	34.18	67.62	30.99
	-19.8	-20	80.63	36.76	80.32	37.15	80.00	35.89	76.83	34.25	73.97	32.64	67.62	29.47
	-18.8	-19	81.27	36.81	80.95	37.15	80.00	35.55	76.83	33.90	73.97	32.29	67.62	29.17
	-16.7	-17	82.54	36.85	82.22	37.24	80.00	34.81	76.83	33.20	73.97	31.64	67.62	28.56

-13.7	-15	83.81	36.94	83.49	37.28	80.00	34.12	76.83	32.55	73.97	31.03	67.62	28.04
-11.8	-13	85.08	36.98	84.76	36.59	80.00	33.42	76.83	31.90	73.97	30.43	67.62	27.52
-9.8	-11	86.35	37.02	86.03	35.85	80.00	32.81	76.83	31.29	73.97	29.86	67.62	27.00
-9.5	-10	86.98	37.07	86.03	35.50	80.00	32.47	76.83	30.99	73.97	29.56	67.62	26.74
-8.5	-9.1	87.62	37.11	86.03	35.20	80.00	32.21	76.83	30.73	73.97	29.30	67.62	26.52
-7	-7.6	88.57	37.15	86.03	34.68	80.00	31.77	76.83	30.34	73.97	28.91	67.62	26.17
-5	-5.6	92.38	36.42	86.03	33.55	80.00	30.77	76.83	29.38	73.97	28.08	67.62	25.43
-3	-3.7	92.38	37.67	86.03	32.33	80.00	29.47	76.83	28.27	73.97	27.06	67.62	24.71
0	-0.7	92.38	37.19	86.03	30.84	80.00	28.44	76.83	27.44	73.97	26.25	67.62	24.15
3	2.2	92.38	34.38	86.03	29.10	80.00	26.83	76.83	26.47	73.97	25.26	67.62	23.20
5	4.1	92.38	31.42	86.03	27.49	80.00	25.60	76.83	25.39	73.97	24.07	67.62	22.70
7	6	92.38	27.56	86.03	25.74	80.00	23.92	76.83	23.00	73.97	22.14	67.62	20.40
9	7.9	92.38	26.13	86.03	24.52	80.00	22.92	76.83	22.14	73.97	21.31	67.62	19.79
11	9.8	92.38	24.83	86.03	23.39	80.00	22.01	76.83	21.31	73.97	20.62	67.62	19.27
13	11.8	92.38	23.70	86.03	22.44	80.00	21.22	76.83	20.62	73.97	20.01	67.62	18.79
15	13.7	92.38	22.87	86.03	21.75	80.00	20.66	76.83	20.14	73.97	19.57	67.62	18.49

Abbreviations:

CR: Combination ratio

TC: Total capacity (kW)

PI: Power input (compressor + outdoor fan motor) (kW)

Notes: Shaded cells indicate rating condition.

Table 2-8.26: 32HP heating capacity (continued)

CR	Outdoor air temp.		Indoor air temp. °C DB											
			16		18		20		21		22		24	
	°C DB	°C WB	TC	PI	TC	PI	TC	PI	TC	PI	TC	PI	TC	PI
70%	-25	-25.4	80.00	38.63	75.24	35.73	70.16	35.12	67.30	34.48	64.76	34.05	59.37	32.77
	-19.8	-20	80.00	36.79	75.24	33.84	70.16	33.16	67.30	32.52	64.76	32.10	59.37	30.82
	-18.8	-19	80.63	36.39	75.24	33.49	70.16	32.81	67.30	32.17	64.76	31.75	59.37	30.47
	-16.7	-17	80.63	35.65	75.24	32.83	70.16	32.24	67.30	31.60	64.76	31.17	59.37	29.90
	-13.7	-15	80.63	34.94	75.24	32.17	70.16	31.62	67.30	30.99	64.76	30.56	59.37	29.28
	-11.8	-13	80.63	34.24	75.24	31.56	70.16	31.10	67.30	30.46	64.76	30.03	59.37	28.75
	-9.8	-11	80.63	33.58	75.24	30.94	70.16	30.53	67.30	29.89	64.76	29.46	59.37	28.18
	-9.5	-10	80.63	33.27	75.24	30.68	70.16	29.76	67.30	29.12	64.76	28.69	59.37	27.41
	-8.5	-9.1	80.63	32.97	75.24	30.42	70.16	28.76	67.30	28.12	64.76	27.70	59.37	26.42
	-7	-7.6	80.63	32.53	75.24	29.98	70.16	27.52	67.30	26.88	64.76	26.45	59.37	25.17
	-5	-5.6	80.63	31.51	75.24	29.10	70.16	26.77	67.30	26.13	64.76	25.70	59.37	24.42
	-3	-3.7	80.63	29.82	75.24	28.22	70.16	25.99	67.30	25.35	64.76	24.92	59.37	23.64
	0	-0.7	80.63	28.24	75.24	26.99	70.16	24.88	67.30	24.24	64.76	23.81	59.37	22.53
	3	2.2	80.63	26.65	75.24	25.52	70.16	23.36	67.30	22.72	64.76	22.30	59.37	21.02
	5	4.1	80.63	25.43	75.24	23.88	70.16	22.48	67.30	21.84	64.76	21.42	59.37	20.14
7	6	80.63	24.44	75.24	22.86	70.16	21.32	67.30	20.74	64.76	20.31	59.37	19.03	
9	7.9	80.63	23.38	75.24	21.98	70.16	20.61	67.30	19.97	64.76	19.55	59.37	18.27	
11	9.8	80.63	22.46	75.24	21.23	70.16	19.79	67.30	19.15	64.76	18.72	59.37	17.44	
13	11.8	80.63	21.63	75.24	20.36	70.16	18.83	67.30	18.19	64.76	17.77	59.37	16.49	
15	13.7	80.63	20.84	75.24	19.45	70.16	18.10	67.30	17.46	64.76	17.03	59.37	15.75	
60%	-25	-25.4	69.21	36.01	64.76	34.05	60.00	32.47	57.78	31.73	55.24	30.40	50.79	28.82
	-19.8	-20	69.21	34.10	64.76	32.48	60.00	31.24	57.78	30.35	55.24	28.98	50.79	27.33
	-18.8	-19	69.21	33.23	64.76	31.36	60.00	30.13	57.78	29.33	55.24	27.85	50.79	26.35
	-16.7	-17	69.21	32.19	64.76	30.39	60.00	29.21	57.78	28.20	55.24	26.80	50.79	25.30
	-13.7	-15	69.21	31.07	64.76	29.48	60.00	28.29	57.78	27.15	55.24	25.76	50.79	24.25
	-11.8	-13	69.21	29.97	64.76	28.39	60.00	27.21	57.78	26.21	55.24	24.66	50.79	23.17
	-9.8	-11	69.21	29.00	64.76	27.34	60.00	25.91	57.78	25.02	55.24	23.61	50.79	22.31
	-9.5	-10	69.21	27.97	64.76	26.24	60.00	24.84	57.78	23.95	55.24	22.58	50.79	21.10
	-8.5	-9.1	69.21	26.80	64.76	25.30	60.00	23.80	57.78	22.92	55.24	21.53	50.79	19.89
	-7	-7.6	69.21	25.81	64.76	24.22	60.00	22.98	57.78	22.15	55.24	20.69	50.79	19.03
	-5	-5.6	69.21	24.85	64.76	23.33	60.00	21.84	57.78	21.23	55.24	19.87	50.79	18.12
	-3	-3.7	69.21	23.99	64.76	22.40	60.00	20.86	57.78	20.38	55.24	18.99	50.79	17.48
	0	-0.7	69.21	23.02	64.76	21.51	60.00	19.93	57.78	19.40	55.24	18.05	50.79	17.15
	3	2.2	69.21	21.97	64.76	20.48	60.00	19.17	57.78	18.61	55.24	17.12	50.79	16.53
	5	4.1	69.21	20.85	64.76	19.61	60.00	18.46	57.78	17.77	55.24	16.74	50.79	16.18
7	6	69.21	19.90	64.76	18.77	60.00	17.59	57.78	17.06	55.24	16.64	50.79	15.87	
9	7.9	69.21	19.56	64.76	18.35	60.00	17.32	57.78	16.65	55.24	15.94	50.79	15.17	
11	9.8	69.21	19.26	64.76	18.08	60.00	16.87	57.78	16.25	55.24	15.61	50.79	14.88	
13	11.8	69.21	18.66	64.76	17.48	60.00	16.34	57.78	15.90	55.24	15.28	50.79	14.55	
15	13.7	69.21	18.44	64.76	17.13	60.00	15.86	57.78	15.52	55.24	14.89	50.79	14.14	
50%	-25	-25.4	57.78	29.81	53.97	28.19	50.16	26.88	47.94	26.27	46.03	25.61	42.22	23.86
	-19.8	-20	57.78	28.23	53.97	26.89	50.16	25.86	47.94	25.12	46.03	24.43	42.22	22.62
	-18.8	-19	57.78	27.51	53.97	25.96	50.16	24.95	47.94	24.28	46.03	23.49	42.22	21.82
	-16.7	-17	57.78	26.65	53.97	25.16	50.16	24.18	47.94	23.35	46.03	22.63	42.22	20.94

-13.7	-15	57.78	25.72	53.97	24.41	50.16	23.42	47.94	22.47	46.03	21.76	42.22	20.07
-11.8	-13	57.78	24.81	53.97	23.51	50.16	22.52	47.94	21.70	46.03	20.85	42.22	19.18
-9.8	-11	57.78	24.01	53.97	22.63	50.16	21.45	47.94	20.71	46.03	19.99	42.22	18.47
-9.5	-10	57.78	23.16	53.97	21.73	50.16	20.57	47.94	19.83	46.03	19.13	42.22	17.47
-8.5	-9.1	57.78	22.19	53.97	20.94	50.16	19.71	47.94	18.98	46.03	18.26	42.22	16.47
-7	-7.6	57.78	21.37	53.97	20.05	50.16	19.03	47.94	18.34	46.03	17.57	42.22	15.75
-5	-5.6	57.78	20.58	53.97	19.31	50.16	18.08	47.94	17.57	46.03	16.88	42.22	15.00
-3	-3.7	57.78	19.86	53.97	18.54	50.16	17.27	47.94	16.87	46.03	16.16	42.22	14.47
0	-0.7	57.78	19.06	53.97	17.81	50.16	16.50	47.94	16.06	46.03	15.38	42.22	14.20
3	2.2	57.78	18.19	53.97	16.96	50.16	15.87	47.94	15.40	46.03	14.61	42.22	14.12
5	4.1	57.78	17.26	53.97	16.23	50.16	15.28	47.94	14.71	46.03	14.29	42.22	13.97
7	6	57.78	16.47	53.97	15.54	50.16	14.57	47.94	14.12	46.03	14.07	42.22	13.57
9	7.9	57.78	16.19	53.97	15.19	50.16	14.34	47.94	13.79	46.03	13.49	42.22	13.14
11	9.8	57.78	15.95	53.97	14.97	50.16	13.97	47.94	13.46	46.03	13.24	42.22	12.90
13	11.8	57.78	15.45	53.97	14.47	50.16	13.53	47.94	13.16	46.03	12.95	42.22	12.63
15	13.7	57.78	15.27	53.97	14.18	50.16	13.13	47.94	12.85	46.03	12.59	42.22	12.29

Abbreviations:

CR: Combination ratio

TC: Total capacity (kW)

PI: Power input (compressor + outdoor fan motor) (kW)

Notes: Shaded cells indicate rating condition.

8.3 Capacity Correction Factors for Piping Length and Level Difference

Figure 2-8.1: Rate of change in cooling capacity

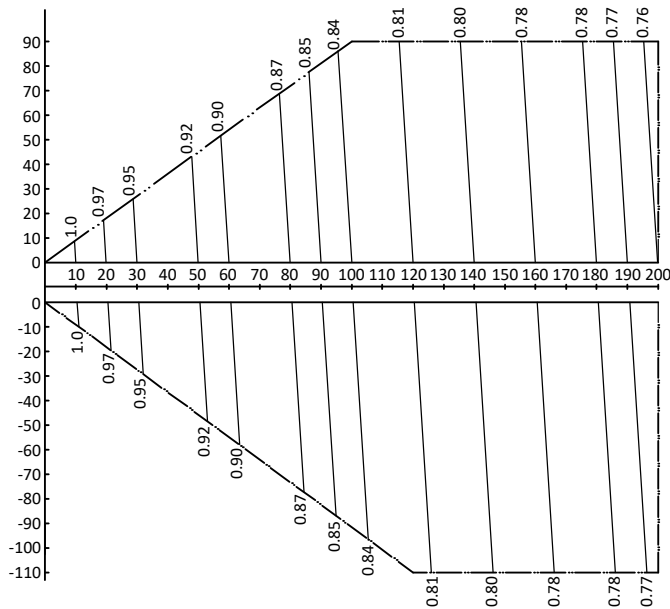
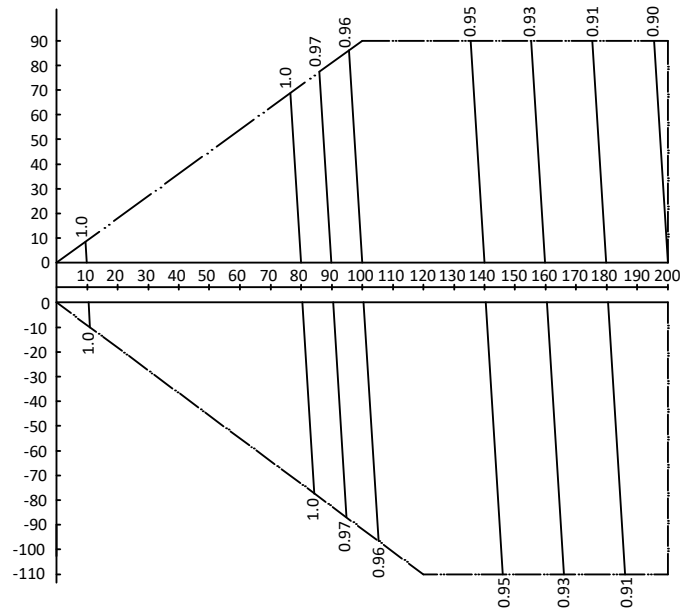

Figure 2-8.2: Rate of change in heating capacity



Notes:

- The horizontal axis shows equivalent length of piping between farthest indoor unit and first outdoor branch joint; the vertical axis shows the largest level difference between indoor unit and outdoor unit. For level differences, positive values indicate that the outdoor unit is above the indoor unit, negative values indicate that the outdoor unit is below the indoor unit.
- These figures illustrate the rate of change in capacity of a system with only standard indoor units at maximum load (with the thermostat set to maximum) under standard conditions. Under partial load conditions there is only a minor deviation from the rate of change in capacity shown in these figures.
- The capacity of the system is either the total capacity of the indoor units obtained from indoor unit capacity tables or the corrected capacity of the outdoor units as per the calculations below, whichever is smaller.

Corrected capacity of outdoor units	=	Capacity of outdoor units obtained from outdoor unit capacity tables at the combination ratio	x	Capacity correction factor
-------------------------------------	---	---	---	----------------------------

8.3 Capacity Correction Factors for Frost Accumulation

The heating capacity tables do not take account of the reduction in capacity when frost has accumulated or while the defrosting operation is in progress. If snow has accumulated against the outside surface of the outdoor unit heat exchanger heating capacity is reduced. The reduction in heating capacity is dependent on a number of factors including the outdoor temperature, the relative humidity and the amount of frosting which has occurred.

Corrected heating capacity values, which take these factors into account, can be calculated as follows, using the correction factors for frost accumulation given in Table 2-8.27:

$$\text{Corrected heating capacity} = \text{Value given in outdoor heating capacity table} \times \text{Correction factor for frost accumulation}$$

Table 2-8.27: Correction factor for frost accumulation

Heat exchanger inlet port temperature (°C / RH 85%)	-7	-5	-2	0	2	5	7
Correction factor for frost accumulation	0.94	0.93	0.89	0.84	0.83	0.91	1.00

Corrected heating capacities express the heating capacity over the heating/defrosting cycle shown in Figure 2-8.43.

Figure 2-8.3: Defrosting cycle

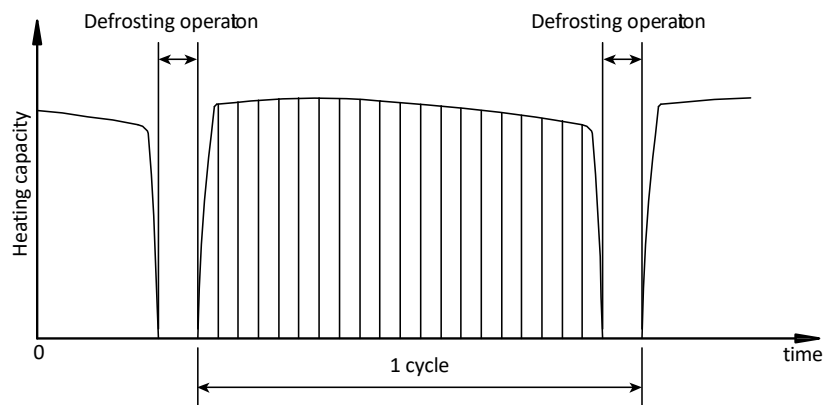

9 Operating Limits

Figure 2-9.1: Cooling operating limits

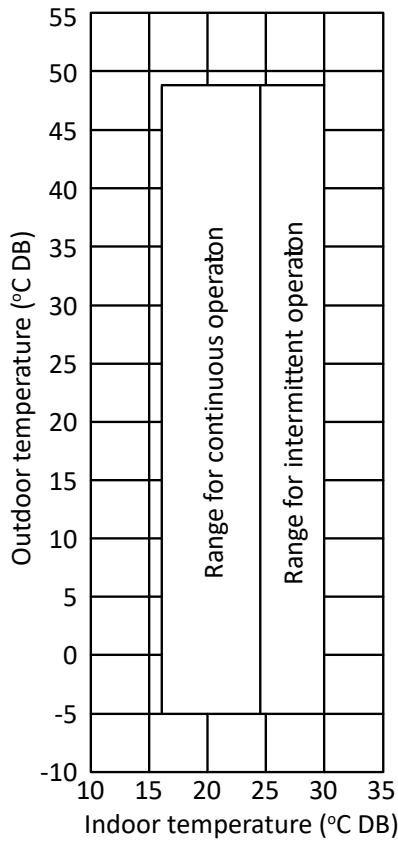
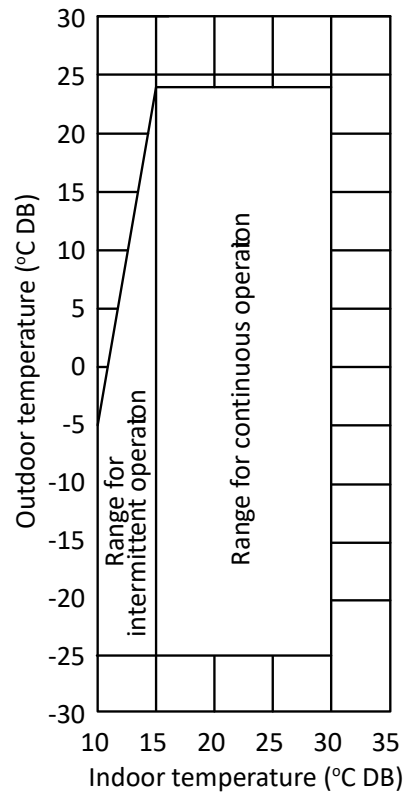

Figure 2-9.2: Heating operating limits



Notes:

- These figures assume the following operating conditions:
 - Equivalent piping length: 7.5m
 - Level difference: 0

10 Sound Levels

10.1 Overall

Table 2-10.1: Sound pressure level

Model	dB(A)
8HP	58
10HP	58
12HP	60
14HP	62
16HP	65
18HP	65
20HP	66
22HP	66
24HP	67
26HP	68
28HP	68
30HP	68
32HP	68
34HP	69
36HP	69

Model	dB(A)
38HP	69
40HP	69
42HP	70
44HP	70
46HP	70
48HP	70
50HP	70
52HP	70
54HP	70
56HP	70
58HP	70
60HP	70
62HP	70
64HP	70
66HP	71

Model	dB(A)
68HP	71
70HP	71
72HP	71
74HP	72
76HP	72
78HP	72
80HP	72
82HP	72
84HP	72
86HP	72
88HP	72
90HP	72
92HP	72
94HP	72
96HP	72

- Notes:
1. Sound pressure level is measured at a position 1m in front of the unit and 1.3m above the floor in a semi-anechoic chamber. During in-situ operation, sound pressure levels may be higher as a result of ambient noise.

Figure 2-10.1: Sound pressure level measurement (unit: mm)

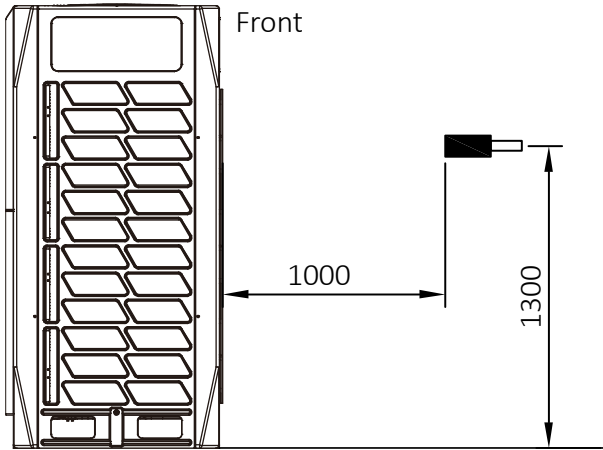
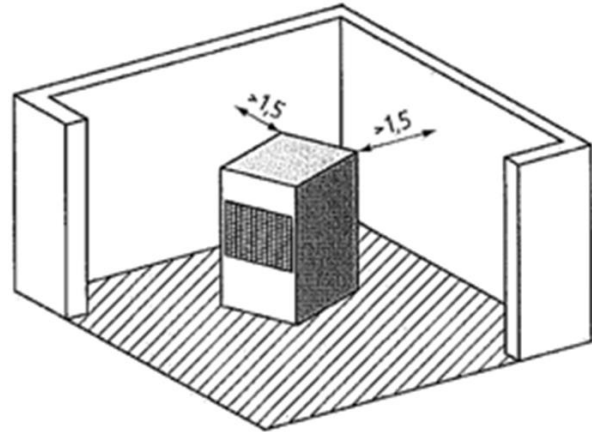

Figure 2-10.2: Sound power level measurement (unit: m)



10.2 Octave Band Levels

Figure 2-10.3 8/10HP octave band level

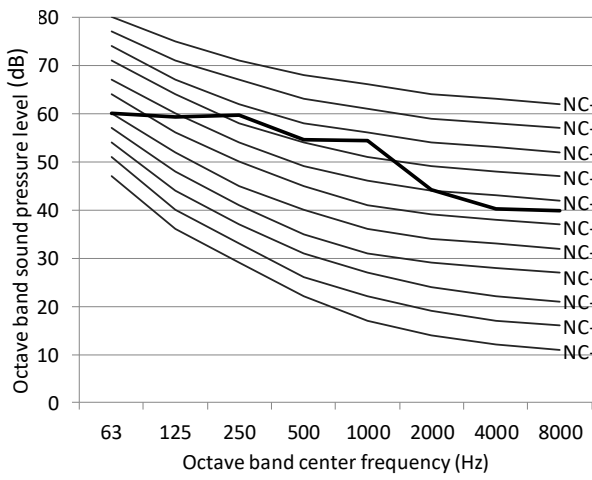

Figure 2-10.4 12HP octave band level

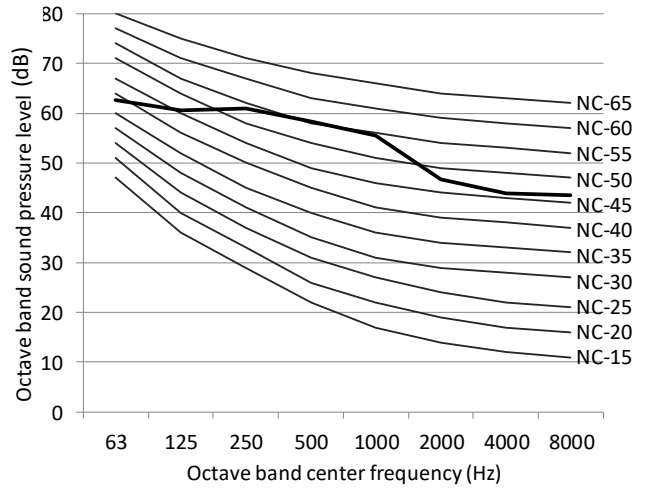

Figure 2-10.5 14HP octave band level

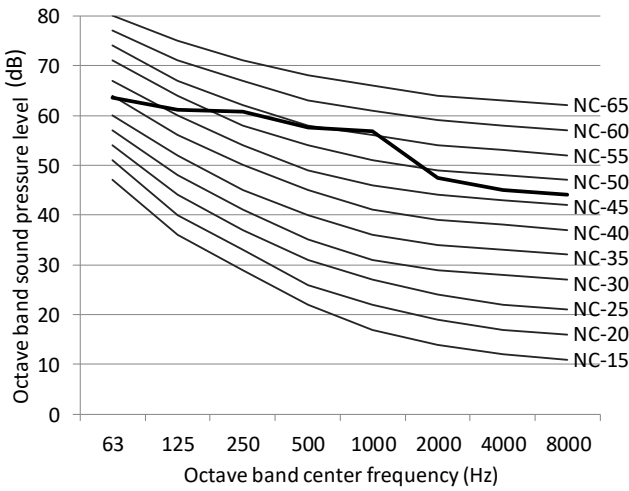

Figure 2-10.6 16-18HP octave band level

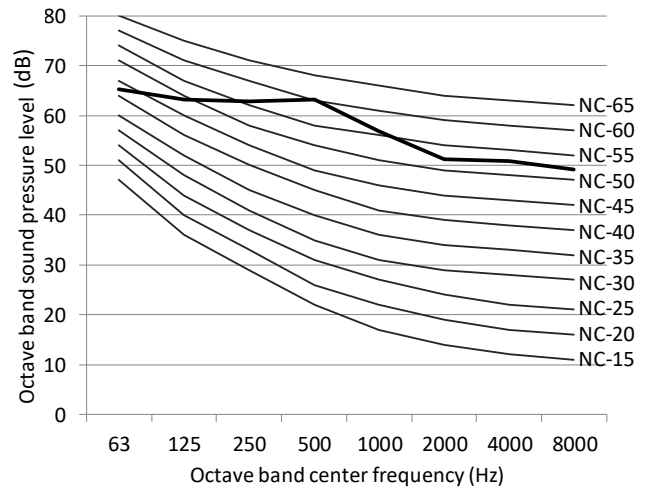

Figure 2-10.7 20/22HP octave band level

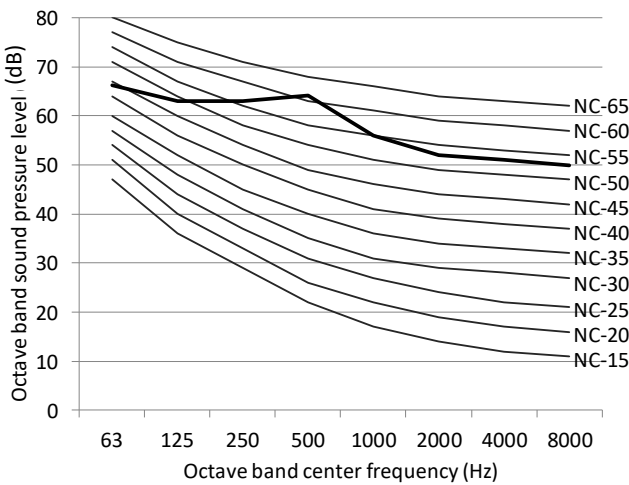

Figure 2-10.8 24HP octave band level

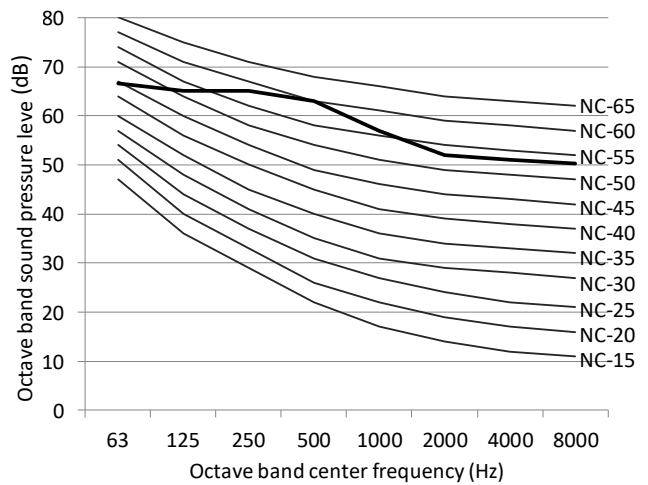
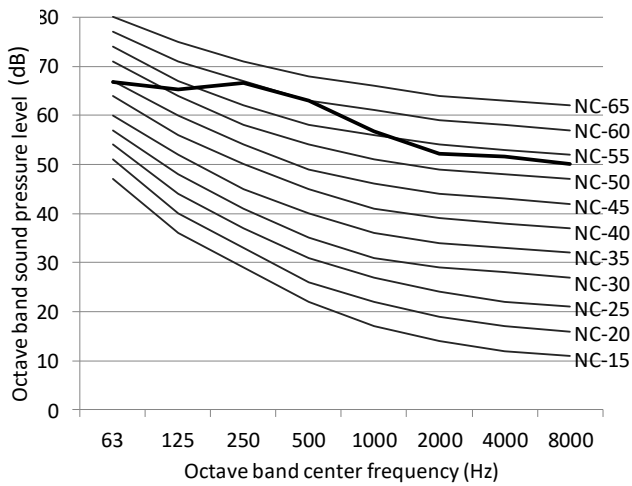

Figure 2-10.9 26/28/30/32HP octave band level



11 Accessories

11.1 Standard Accessories

Table 2-11.1: Standard accessories

Name	Shape	Quantity	Function
Outdoor unit installation manual		1	
Outdoor unit owner's manual		1	
Indoor unit owner's manual		2	
Flat-blade screwdriver	-	1	Adjusting indoor and outdoor unit dial switches
90° elbow		1	Connecting pipes
Seal plug		8	Used in pipe flushing
Connection pipe		3	Connecting pipes
Matched resistor		2	Enhances communication stability
Wrench		1	Removing side plate
Accessory bag	-	1	

11.2 Optional Accessories

Table 2-11.2: Optional accessories

Optional accessories	Model	Packed dimensions (mm)	Net/gross weight (kg)	Function
Outdoor branch joint kits	FQZHW-02N1E	255×150×185	1.8 / 2.0	Distribute refrigerant to indoor units and balance flow resistance between outdoor units
	FQZHW-03N1E	345×160×285	3.7 / 4.3	
Indoor branch joint kits	FQZHN-01D	290×105×100	0.3 / 0.4	
	FQZHN-02D	290×105×100	0.4 / 0.6	
	FQZHN-03D	310×130×125	0.6 / 0.9	
	FQZHN-04D	350×170×180	1.1 / 1.5	
	FQZHN-05D	365×195×215	1.4 / 1.9	
	FQZHN-06D	390×230×255	2.5 / 3.1	
	FQZHN-07D	390×230×255	2.8 / 3.4	

Part 3

System Design and Installation

1	Preface to Part 3	215
2	Unit Placement and Installation.....	216
3	Outdoor Unit Ducting and Shielding	219
4	Refrigerant Piping Design.....	225
5	Refrigerant Piping Installation.....	235
6	Drain Piping	247
7	Insulation	250
8	Charging Refrigerant	252
9	Electrical Wiring.....	254
10	Installation in Areas of High Salinity	258
11	Commissioning	258
12	Appendix to Part 3 – System Commissioning Report	261

1 Preface to Part 3

1.1 Notes for Installers Boxes

The information contained in this Engineering Data Book may primarily be of use during the system design stage of a MDV6 Series VRF project. Additional important information which may primarily be of use during field installation has been placed in boxes, such as the example below, titled “Notes for installers”.

Notes for installers



- Notes for installers boxes contain important information which may primarily be of use during field installation, rather than during desk-based system design.

1.2 Definitions

In this Engineering Data Book, the term “applicable legislation” refers to all national, local and other laws, standards, codes, rules, regulations and other legislation that apply in a given situation.

1.3 Precautions

All system installation including installation of piping and electrical works must only be carried out by competent and suitably qualified, certified and accredited professionals and in accordance with all applicable legislation.

2 Unit Placement and Installation

2.1 Outdoor Units

2.1.1 Placement considerations

Placement of outdoor units should take account of the following considerations:

- Air conditioners should not be exposed to direct radiation from a high-temperature heat source.
- Air conditioners should not be installed in positions where dust or dirt may affect heat exchangers.
- Air conditioners should not be installed in locations where exposure to oil or to corrosive or harmful gases, such as acidic or alkaline gases, may occur.
- Air conditioners should not be installed in locations where exposure to salinity may occur unless the anti-corrosion treatment for high-salinity areas customization option has been added and the precautions described in Part 3, 10 “Installation in Areas of High Salinity” are taken.
- Outdoor units should be installed in well-drained, well-ventilated positions that are as close as possible to the indoor units.

2.1.2 Spacing

Outdoor units must be spaced such that sufficient air may flow through each unit. Sufficient airflow across heat exchangers is essential for outdoor units to function properly. Figures 3-2.1 to 3-2.3 show spacing requirements in three different scenarios.

If the particular circumstances of an installation require a unit to be placed closer to a wall than specified in Figures 3-2.1 to 3-2.3, a discharge duct should be installed. Refer to Part 3, 3 “Outdoor Unit Ducting and Shielding”. Depending on the height of adjacent walls relative to the height of the units, ducting may be required. Refer to Part 3, 3 “Outdoor Unit Ducting and Shielding”.

Figure 3-2.1: Single unit installation (unit: mm)

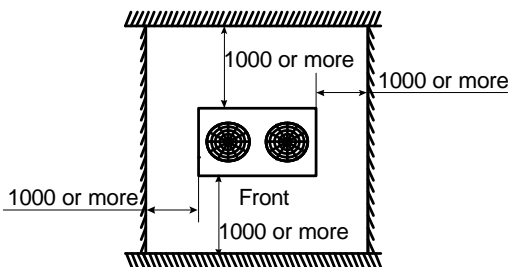

Figure 3-2.2: Single row installation (unit: mm)

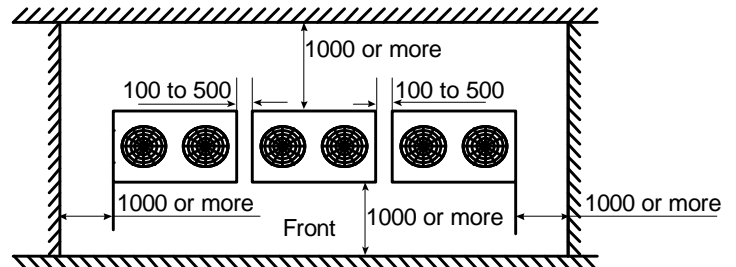
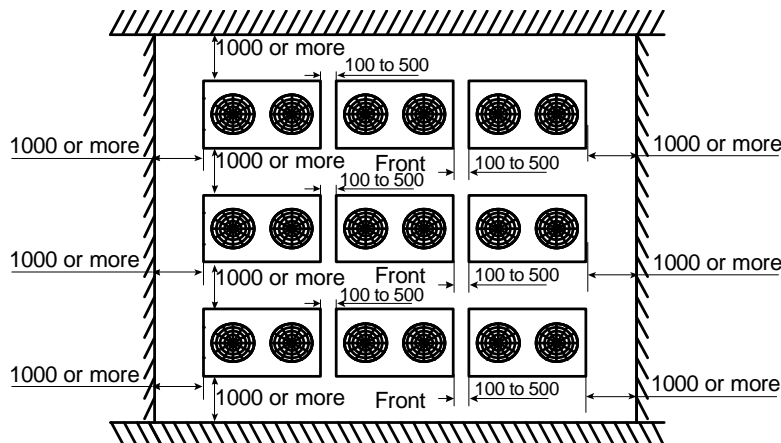

Figure 3-2.3: Multi-row installation (unit: mm)



2.1.3 Master and slave unit positioning

In systems with multiple outdoor units, the units should be placed in order from largest capacity unit to smallest capacity unit. The largest capacity unit must be placed on the first branch, and be set as the master unit, while the others should be set as slave units. Refer to the V6 Service Manual, Part 4 for details of how to set units as master/slave.

The example in Figure 3-2.4 illustrates the placing of units in a 48HP combination:

- Place the 22HP unit on the first branch and set it as the master unit.
- Place the 16HP and 10HP units on the next branches and set them as slave units.

Figure 3-2.4: Positioning of master and slave units

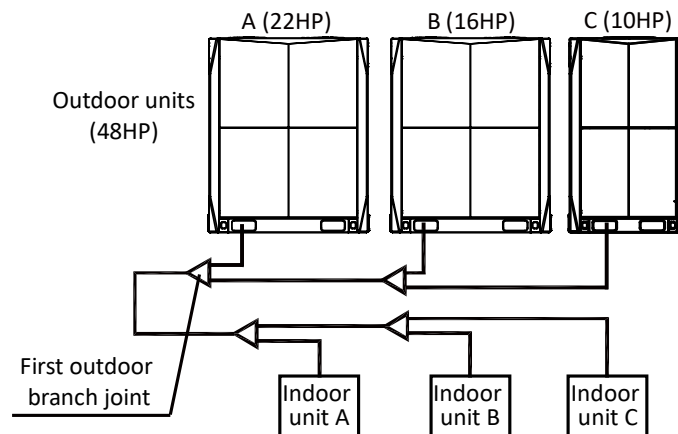

2.1.4 Base structures

Outdoor unit base structure design should take account of the following considerations:

- A solid base prevents excess vibration and noise. Outdoor unit bases should be constructed on solid ground or on structures of sufficient strength to support the units' weight.
- Bases should be at least 200mm high to provide sufficient access for installation of piping.
- Either steel or concrete bases may be suitable.
- A typical concrete base design is shown in Figure 3-2.5. A typical concrete specification is 1 part cement, 2 parts sand and 4 parts crushed stone with $\Phi 10\text{mm}$ steel reinforcing bar. The edges of the base should be chamfered.
- To ensure that all contact points are equally secure, bases should be completely level. Base design should ensure that the points on the units' bases designed for weight-bearing support are fully supported. Bolt spacings should be as per Figure 3-2.6 and Table 3-2.1.
- A drainage ditch should be provided to allow drainage of condensate that may form on the heat exchangers when the units are running in heating mode. The drainage should ensure that condensate is directed away from roadways and footpaths, especially in locations where the climate is such that condensate may freeze.

Figure 3-2.5: Outdoor unit typical concrete base structure design (unit: mm)

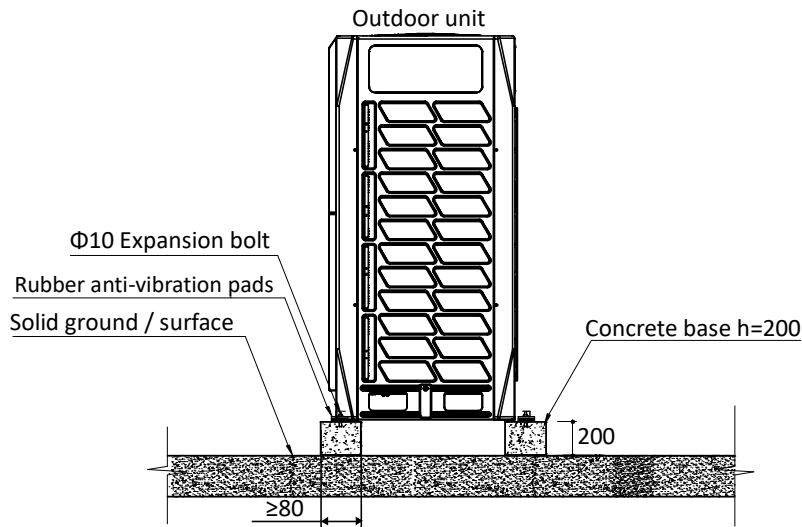

Figure 3-2.6: Expansion bolt positioning

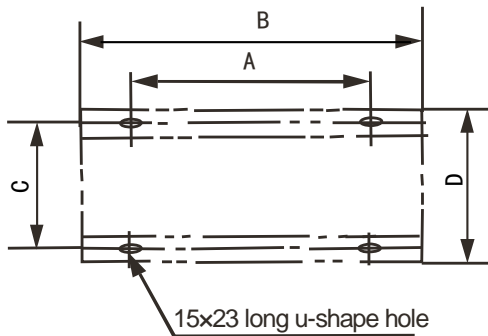

Table 3-2.1: Expansion bolt spacings

Dimension (mm)	8-12HP	14-22HP	24-32HP
A	740	1090	1480
B	990	1340	1730
C	723	723	723
D	790	790	790

2.1.5 Acceptance and unpacking

Notes for installers



- When units are delivered check whether any damage occurred during shipment. If there is damage to the surface or outside of a unit, submit a written report to the shipping company.
- Check that the model, specifications and quantity of the units delivered are as ordered.
- Check that all accessories ordered have been included. Retain the Owner's Manual for future reference.

2.1.6 Hoisting

Notes for installers



- Do not remove any packaging before hoisting. If units are not packaged or if the packaging is damaged, use suitable boards or packing material to protect the units.
- Hoist one unit at a time, using two ropes to ensure stability.
- Keep units upright during hoisting, ensuring that the angle to the vertical does not exceed 30°.

2.2 Indoor Units

2.2.1 Placement considerations

Placement of indoor units should take account of the following considerations:

- Sufficient space for drain piping and for access during servicing and maintenance should be allowed.
- To ensure a good cooling/heating effect, short-circuit ventilation (where outlet air returns quickly to a unit’s air inlet) should be avoided.
- To prevent excessive noise or vibration during operation, suspension rods or other weight-bearing fixings should typically be able to bear twice the unit’s weight.

Notes for installers



- Before installing an indoor unit, check that the model to be installed is as specified in the construction drawings and confirm the correct orientation of the unit.
- Ensure that units are installed at the correct height.
- To allow smooth condensate drainage and to ensure unit stability (to prevent excessive noise or vibration), ensure that units are level to within 1° of the horizontal. If a unit is not level to within 1° of the horizontal, water leakage or abnormal vibration/noise may occur.

3 Outdoor Unit Ducting and Shielding

3.1 Ducting Requirements

Depending on the height of adjacent walls relative to the height of the units, ducting may be required to ensure proper air discharge. In the situation depicted in Figure 3-3.1, the vertical section of ducting should be at least H-h high.

Figure 3-3.1: Top of unit below top of adjacent wall

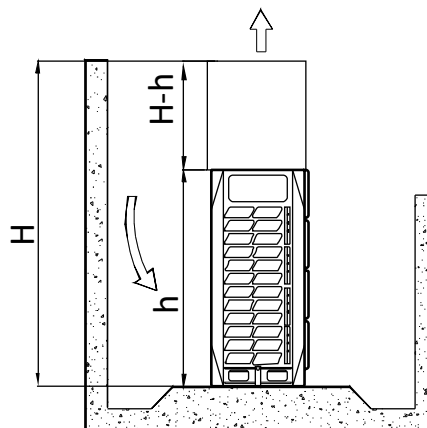

3.2 Design Considerations

Outdoor unit ducting design should take account of the following:

- Each duct should contain no more than one bend.
- Vibration isolation should be added to the connection between the unit and the ducting to avoid vibration/noise.
- Installing louvers is required as doing for safety, they should be installed at an angle no greater than 15° to the horizontal, to minimize the impact on airflow.

MDV6 VRF 50Hz

3.3 Ducting for 8HP, 10HP and 12HP Units

3.3.1 Option A – Transverse ducting

Figure 3-3.2: Transverse ducting for 8HP, 10HP and 12HP units (unit: mm)

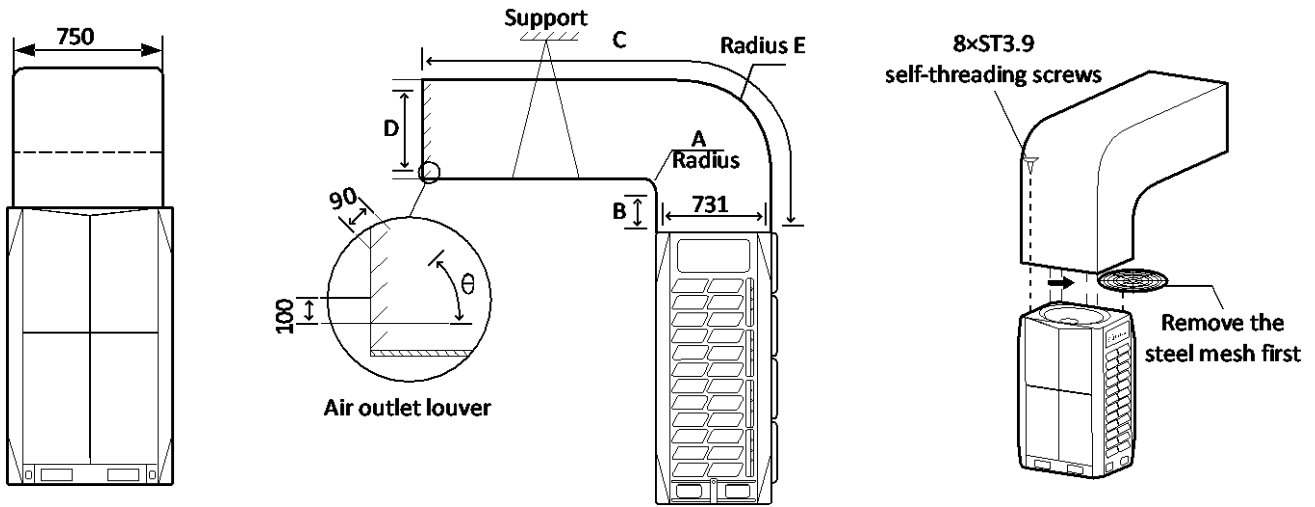

Table 3-3.1: Duct dimensions

Dimensions (mm)	
A	$A \geq 300$
B	$B \geq 250$
C	$C \leq 3000$
D	$731 \leq D \leq 770$
E	$E = A + 731$
θ	$\theta \leq 15^\circ$

Table 3-3.2: External static pressure

ESP (Pa)	Remarks
0	Factory default
0 – 20	Remove steel mesh and connect to duct < 3m long
> 20	Customization option

3.3.2 Option B – Longitudinal ducting

Figure 3-3.3: Longitudinal ducting for 8HP, 10HP and 12HP units (unit: mm)

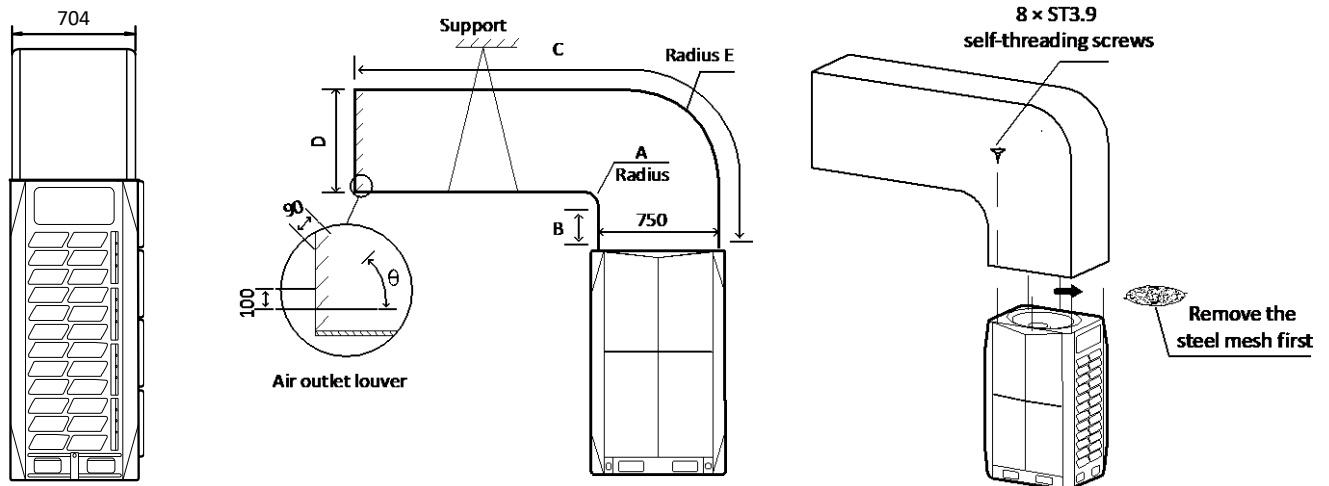

Table 3-3.3: Duct dimensions

Dimensions (mm)	
A	$A \geq 300$
B	$B \geq 250$
C	$C \leq 3000$
D	$D \geq 750$
E	$E = A + 750$
θ	$\theta \leq 15^\circ$

Table 3-3.4: External static pressure

ESP (Pa)	Remarks
0	Factory default
0 – 20	Remove steel mesh and connect to duct < 3m long
> 20	Customization option

Ducting for 14HP and 16HP Units

3.3.3 Option A – Transverse ducting

Figure 3-3.4: Transverse ducting for 14HP and 16HP units (unit: mm)

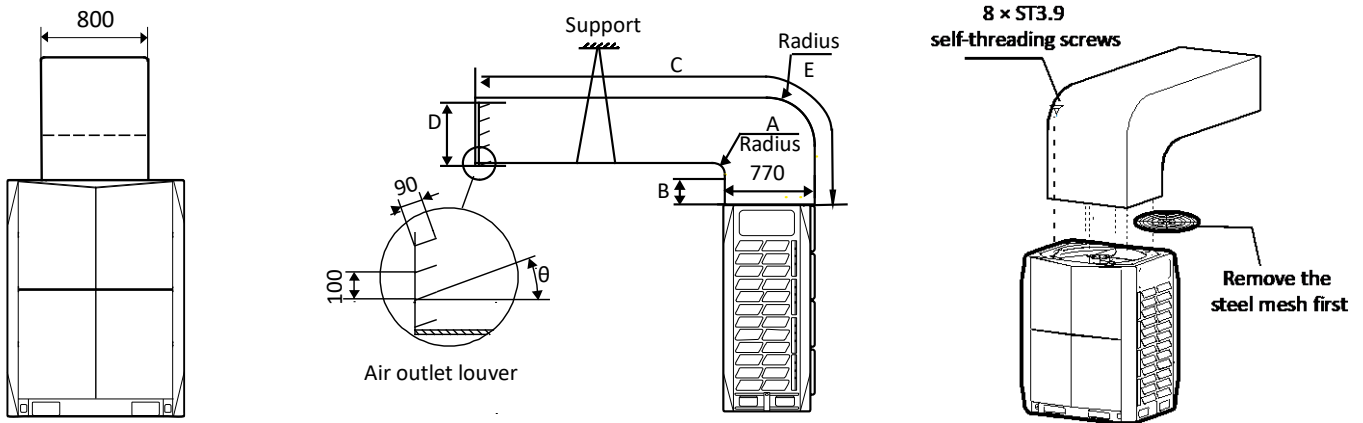

Table 3-3.5: Duct dimensions

Dimensions (mm)	
A	$A \geq 300$
B	$B \geq 250$
C	$C \leq 3000$
D	$770 \leq D \leq 800$
E	$E = A + 770$
θ	$\theta \leq 15^\circ$

Table 3-3.6: External static pressure

ESP (Pa)	Remarks
0	Factory default
0 – 20	Remove steel mesh and connect to duct < 3m long
> 20	Customization option

3.3.4 Option B – Longitudinal ducting

Figure 3-3.5: Longitudinal ducting for 14HP and 16HP units (unit: mm)

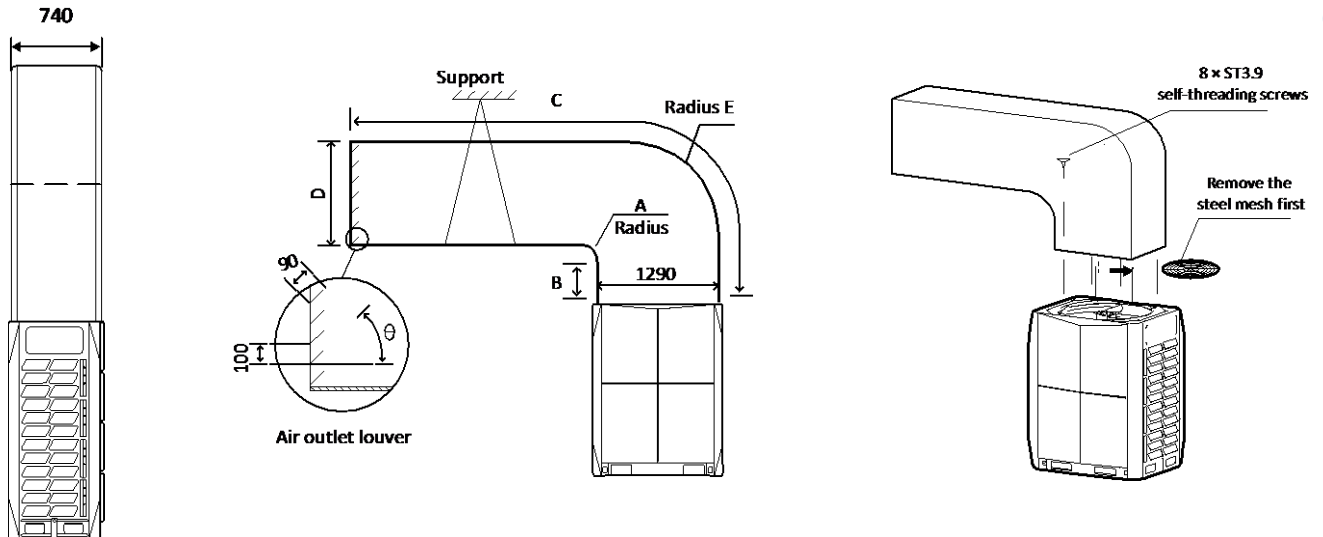

Table 3-3.7: Duct dimensions

Dimensions (mm)	
A	$A \geq 300$
B	$B \geq 250$
C	$C \leq 3000$
D	$D \geq 1290$
E	$E = A + 1290$
θ	$\theta \leq 15^\circ$

Table 3-3.8: External static pressure

ESP (Pa)	Remarks
0	Factory default
0 – 20	Remove steel mesh and connect to duct < 3m long
> 20	Customization option

Ducting for 18HP, 20HP and 22HP Units

3.3.5 Option A – Transverse ducting

Figure 3-3.6: Transverse ducting for 18HP, 20HP and 22HP units (unit: mm)

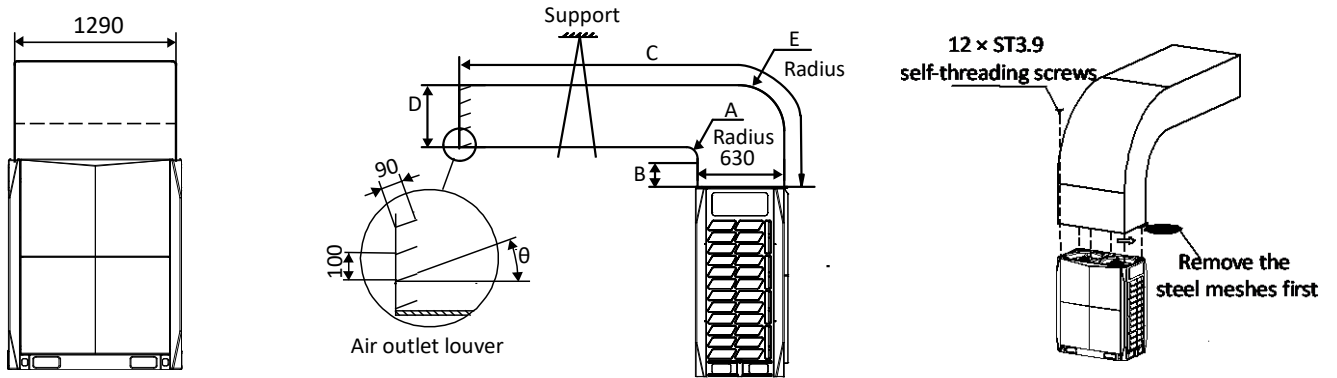

Table 3-3.9: Duct dimensions

Dimensions (mm)	
A	$A \geq 300$
B	$B \geq 250$
C	$C \leq 3000$
D	$630 \leq D \leq 660$
E	$E = A + 630$
θ	$\theta \leq 15^\circ$

Table 3-3.10: External static pressure

ESP (Pa)	Remarks
0	Factory default
0 – 20	Remove steel mesh and connect to duct < 3m long
> 20	Customization option

3.3.6 Option B – Longitudinal ducting

Figure 3-3.7: Longitudinal ducting for 18HP, 20HP and 22HP units (unit: mm)

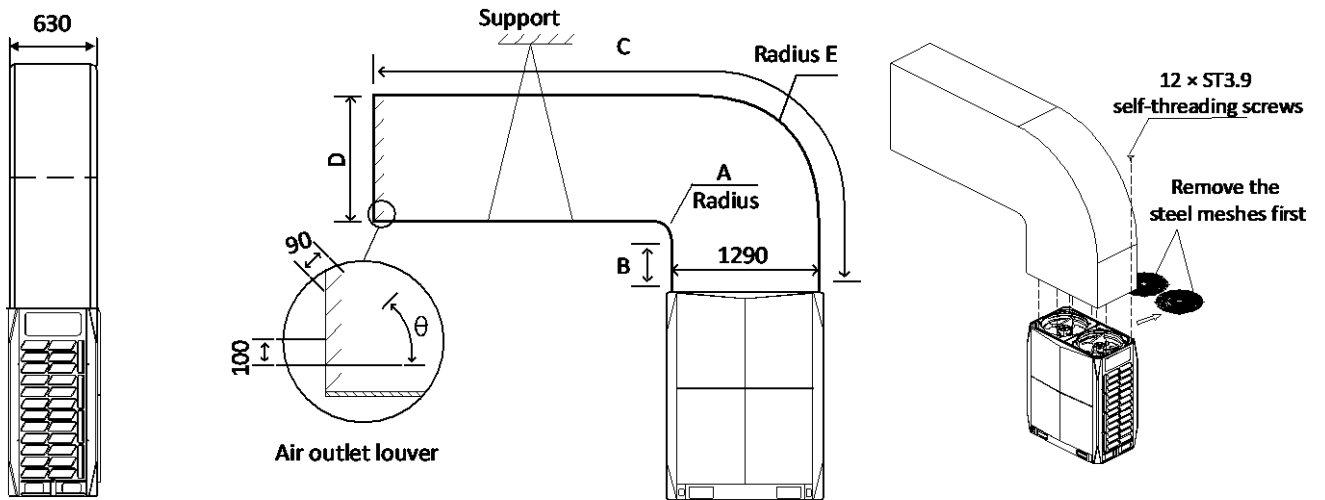

Table 3-3.11: Duct dimensions

Dimensions (mm)	
A	$A \geq 300$
B	$B \geq 250$
C	$C \leq 3000$
D	$D \geq 1290$
E	$E = A + 1290$
θ	$\theta \leq 15^\circ$

Table 3-3.12: External static pressure

ESP (Pa)	Remarks
0	Factory default
0 – 20	Remove steel mesh and connect to duct < 3m long
> 20	Customization option

Ducting for 24HP, 26HP, 28HP, 30HP and 32HP Units

3.3.7 Transverse ducting only

Figure 3-3.8: Transverse ducting for 24HP, 26HP, 28HP, 30HP and 32HP units (unit: mm)

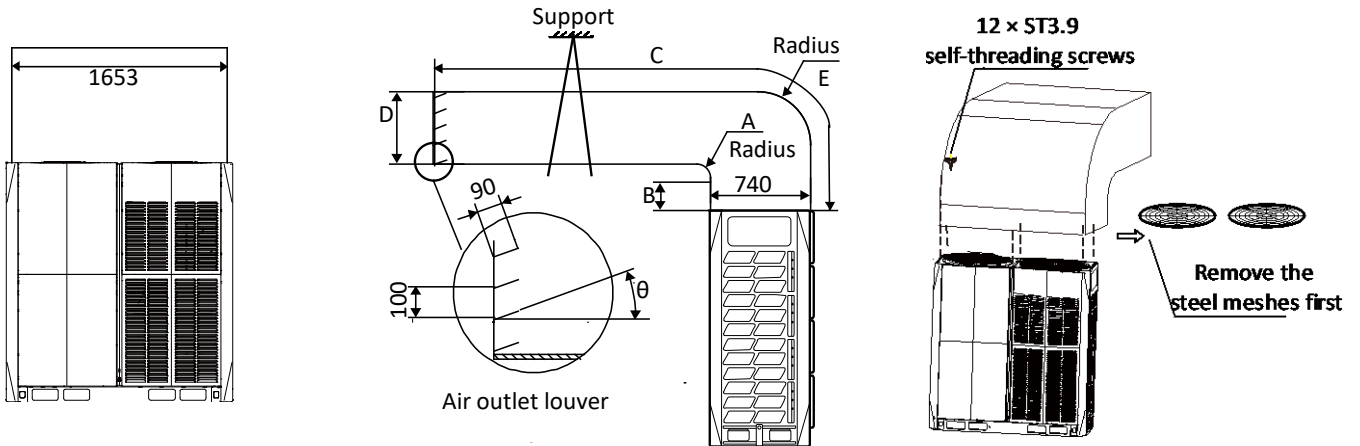

Table 3-3.13: Duct dimensions

Dimensions (mm)	
A	$A \geq 300$
B	$B \geq 250$
C	$C \leq 3000$
D	$740 \leq D \leq 770$
E	$E = A + 740$
θ	$\theta \leq 15^\circ$

Table 3-3.14: External static pressure

ESP (Pa)	Remarks
0	Factory default
0 – 20	Remove steel mesh and connect to duct < 3m long
> 20	Customization option

3.4 Fan Performance

The default external static pressure of outdoor units' air outlets is zero. With the steel mesh cover removed the external static pressure is 20Pa.

Figure 3-3.9: 8-12HP units fan performance

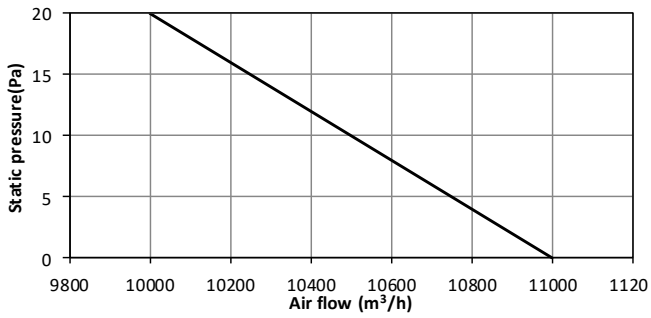

Figure 3-3.10: 14-16HP units fan performance

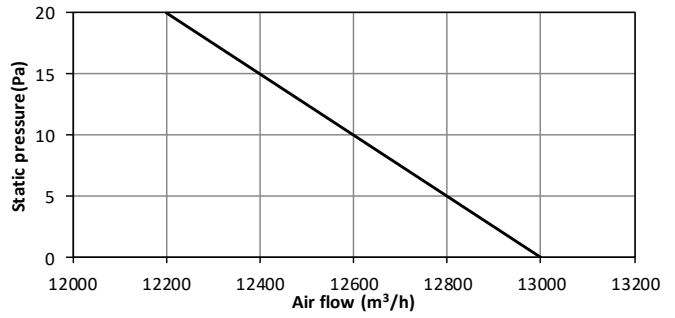

Figure 3-3.11: 18-22HP units fan performance

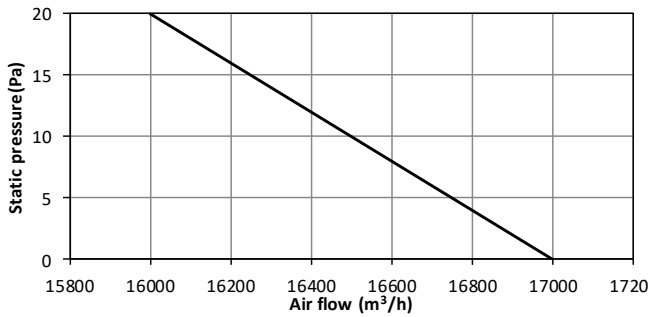

Figure 3-3.12: 24-28HP units fan performance

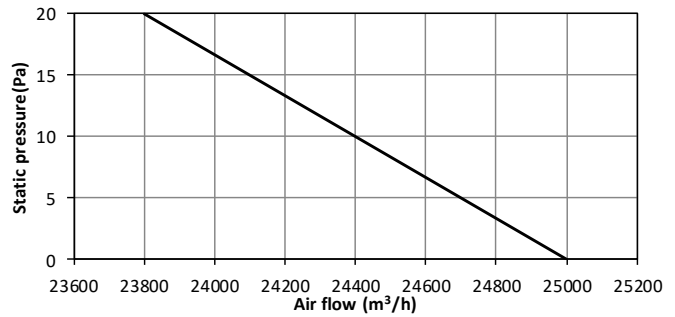
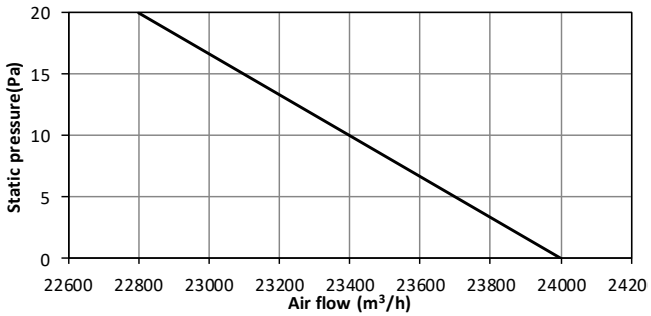

Figure 3-3.13: 30-32HP units fan performance



Notes for installers



- Before installing outdoor unit ducting, be sure to remove the unit's steel mesh cover, otherwise airflow will be adversely affected.

3.5 Snow Shielding

In areas of high snowfall, snow shields should be installed on air inlets and outlets to prevent snow from entering the units. Additionally, the height of the base structures should be increased so as to raise the units further off the ground.

Figure 3-3.14: Outdoor unit snow shielding

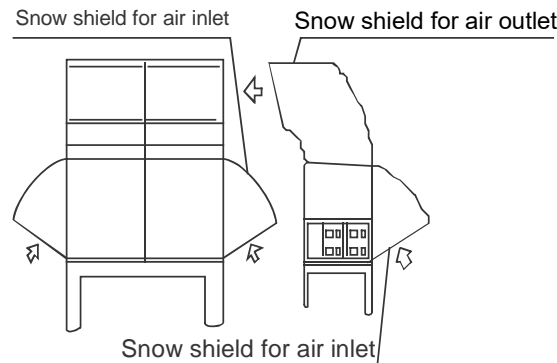

4 Refrigerant Piping Design

4.1 Design Considerations

Refrigerant piping design should take account of the following considerations:

- The amount of brazing required should be kept to a minimum.
- On the two inside sides of the first indoor branch joint (“A” in Figures 3-4.2, 3-4.3 and 3-4.4) the system should, as far as possible, be equal in terms of number of units, total capacities and total piping lengths.

4.2 Material Specification

Only seamless phosphorus-deoxidized copper piping that complies with all applicable legislation should be used. Temper grades and minimum thicknesses for different diameters of piping are specified in Table 3-4.1.

Table 3-4.1: Piping temper and thickness

Piping outer diameter (mm)	Temper ¹	Minimum thickness (mm)
Φ6.35	O (annealed)	0.8
Φ9.53		0.8
Φ12.7		0.8
Φ15.9		1.0
Φ19.1		1.0
Φ22.2	1/2H (half hard)	1.2
Φ25.4		1.2
Φ28.6		1.3
Φ31.8		1.5
Φ38.1		1.5
Φ41.3		1.5
Φ44.5		1.5
Φ54.0		1.8

Notes:

1. O: coiled piping; 1/2H: straight piping.

4.3 Permitted Piping Lengths and Level Differences

The piping length and level difference requirements that apply are summarized in Table 3-4.3 and are fully described as follows (refer to Figure 3-4.2):

1. **Requirement 1:** The total length of piping in one refrigerant system should not exceed 1000m. When calculating the total length of piping, the actual length of the indoor main pipes (the piping between the first indoor branch joint and all other indoor branch joints, L_2 to L_{16}) should be doubled.
2. **Requirement 2:** The piping between the farthest indoor unit (N_{11}) and the first outdoor branch joint (L) should not exceed 175m (actual length) and 200m (equivalent length). (The equivalent length of each branch joint is 0.5m.)
3. **Requirement 3:** The piping between the farthest indoor unit (N_{11}) and first indoor branch joint (A) should not exceed 40m in length ($\sum\{L_9 \text{ to } L_{13}\} + k \leq 40\text{m}$) unless the following conditions are met and the following measures are taken, in which case the permitted length is up to 90m:

Conditions:

- a) Each indoor auxiliary pipe (from each indoor unit to its nearest branch joint) joint does not exceed 20m in length (a to q each $\leq 20\text{m}$).
- b) The difference in length between {the piping from first indoor branch joint (A) to the farthest indoor unit (N_{11})} and {the piping from the first indoor branch joint (A) to the nearest indoor unit (N_1)} does not exceed 40m. That is: $(\sum\{L_9 \text{ to } L_{13}\} + k) - (\sum\{L_2 \text{ to } L_3\} + a) \leq 40\text{m}$.

Measures:

- a) Increase the diameter of the indoor main pipes (the piping between the first indoor branch joint and all other indoor branch joints, L_2 to L_{16}) as per Table 3-4.2, except for indoor main pipes which are already the same size as the main pipe (L_1), for which no diameter increases are required.
4. **Requirement 4:** The largest level difference between indoor unit and outdoor unit should not exceed 90m (if the outdoor unit is above) or 110m (if the outdoor unit is below). Additionally: (i) If the outdoor unit is above and the level difference is greater than 20m, it is recommended that an oil return bend with dimensions as specified in Figure 3-4.1 is set every 10m in the gas pipe of the main pipe; and (ii) if the outdoor unit is below and the level difference is more than 40m, the liquid pipe of the main pipe (L_1) should be increased as per Table 3-4.2.
5. **Requirement 5:** The largest level difference between indoor units should not exceed 30m.

Table 3-4.2: Diameter increase requirements

Original (mm)	Increased (mm)
Φ9.53	Φ12.7
Φ12.7	Φ15.9
Φ15.9	Φ19.1
Φ19.1	Φ22.2
Φ22.2	Φ25.4
Φ25.4	Φ28.6
Φ28.6	Φ31.8
Φ31.8	Φ38.1
Φ38.1	Φ41.3
Φ41.3	Φ44.5
Φ44.5	Φ54.0

Figure 3-4.1: Oil return bend (unit: mm)

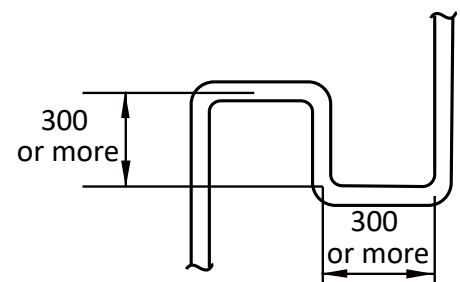
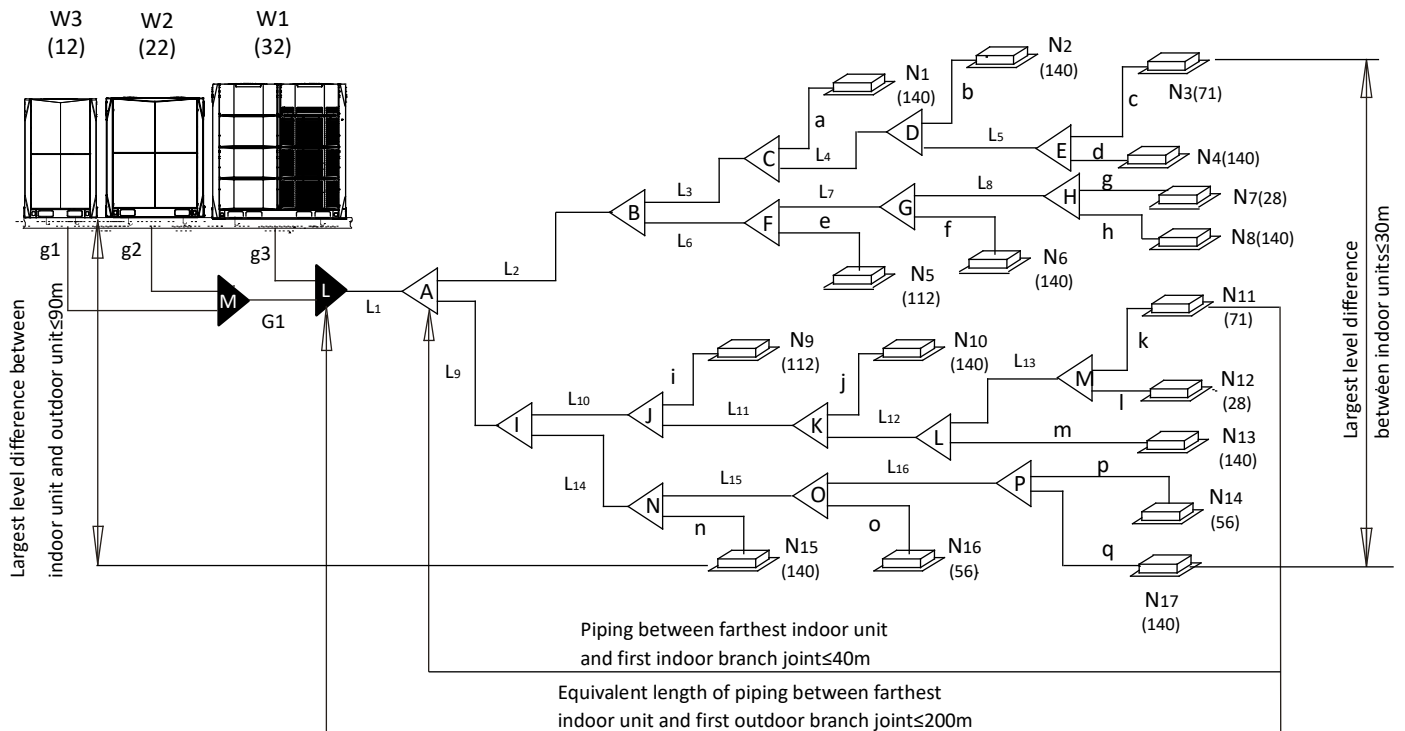

Figure 3-4.2: Permitted refrigerant piping lengths and level differences



Legend	
L ₁	Main pipe
L ₂ to L ₁₆	Indoor main pipes
a to q	Indoor auxiliary pipes
A to P	Indoor branch joints
L, M	Outdoor branch joints
g ₁ to g ₃ , G ₁	Outdoor connection

Figures in parentheses indicate indoor unit capacity indexes.

Table 3-4.3: Summary of permitted refrigerant piping lengths and level differences

		Permitted values	Piping in Figure 3-4.2
Piping lengths	Total piping length ¹	≤ 1000m	$L_1 + 2 \times \sum\{L_2 \text{ to } L_{16}\} + \sum\{a \text{ to } q\}$
	Piping between farthest indoor unit and first outdoor branch joint ²	Actual length	≤ 175m
		Equivalent length	≤ 200m
	Piping between farthest indoor unit and first indoor branch joint ³	≤ 40m / 90m	$\sum\{L_9 \text{ to } L_{13}\} + k$
Piping between outdoor unit and outdoor branch joint	≤ 10m	$g_1 + G_1 \leq 10m; g_2 + G_1 \leq 10m; g_3 \leq 10m$	
Level differences	Largest level difference between indoor unit and outdoor unit ⁴	Outdoor unit is above	≤ 90m
		Outdoor unit is below	≤ 110m
	Largest level difference between indoor units ⁵	≤ 30m	

Notes:

1. Refer to Requirement 1, above.
2. Refer to Requirement 2, above.
3. Refer to Requirement 3, above.
4. Refer to Requirement 4, above.
5. Refer to Requirement 5, above.

4.4 Selecting Piping Diameters

Tables 3-4.4 to 3-4.8, below, specify the required pipe diameters for the indoor and outdoor piping. The main pipe (L₁) and first indoor branch joint (A) should be sized according to whichever of Tables 3-4.4 and 3-4.5 indicates the larger size.

Figure 3-4.3: Selecting piping diameters

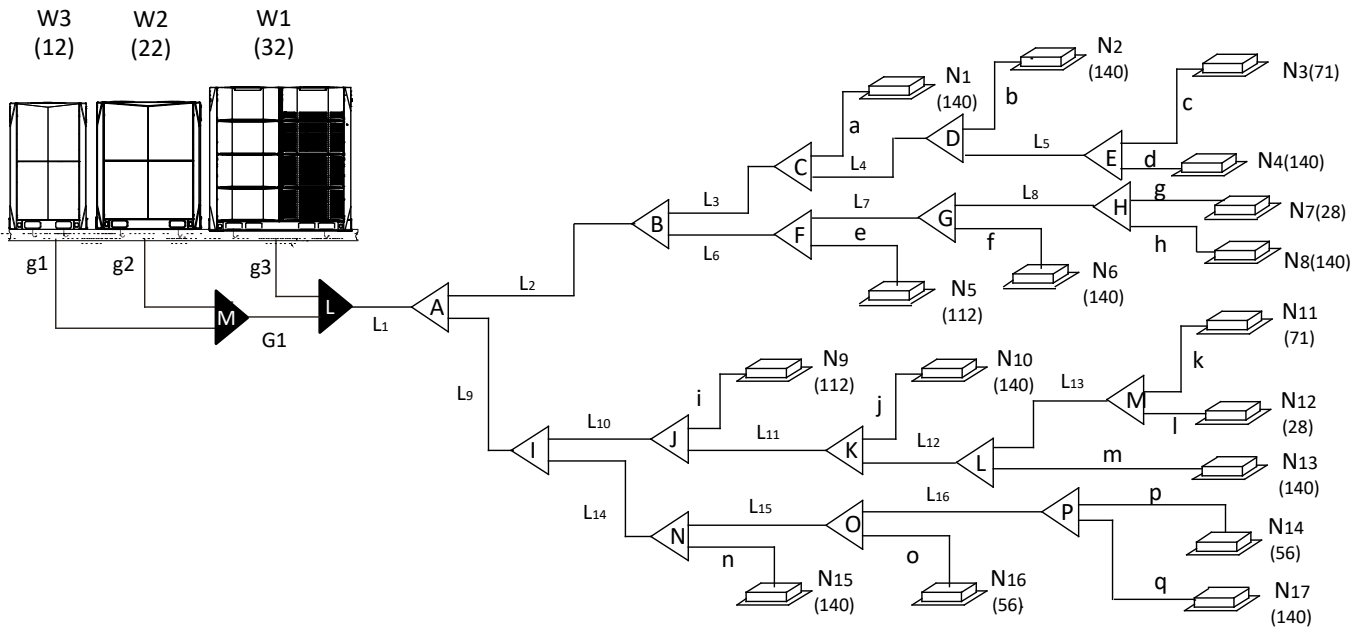

Legend		Figures in parentheses indicate indoor unit capacity indexes.
L ₁	Main pipe	
L ₂ to L ₁₆	Indoor main pipes	
a to q	Indoor auxiliary pipes	
A to P	Indoor branch joints	
L, M	Outdoor branch joints	
g ₁ to g ₃ , G ₁	Outdoor connection pipes	

Table 3-4.4: Main pipe¹ (L₁), indoor main pipes (L₂ to L₁₆) and indoor branch joint kits

Total capacity indexes of indoor units	Gas pipe (mm)	Liquid pipe (mm)	Branch joint kit
Capacity indexes < 168	Φ15.9	Φ9.53	FQZHN-01D
168 ≤ Capacity indexes < 224	Φ19.1	Φ9.53	FQZHN-01D
224 ≤ Capacity indexes < 330	Φ22.2	Φ9.53	FQZHN-02D
330 ≤ Capacity indexes < 470	Φ28.6	Φ12.7	FQZHN-03D
470 ≤ Capacity indexes < 710	Φ28.6	Φ15.9	FQZHN-03D
710 ≤ Capacity indexes < 1040	Φ31.8	Φ19.1	FQZHN-03D
1040 ≤ Capacity indexes < 1540	Φ38.1	Φ19.1	FQZHN-04D
1540 ≤ Capacity indexes < 1800	Φ41.3	Φ19.1	FQZHN-05D
1800 ≤ Capacity indexes < 2450	Φ44.5	Φ22.2	FQZHN-05D
2450 ≤ Capacity indexes < 2690	Φ54.0	Φ25.4	FQZHN-06D
2690 ≤ Capacity indexes	Φ54.0	Φ28.6	FQZHN-07D

Notes:

- The main pipe (L₁) and first indoor branch joint (A) should be sized according to whichever of Tables 3-4.4 and 3-4.5 indicates the larger size.

Table 3-4.5: Main pipe¹ (L₁) and first indoor branch joint (A)

Total capacity of outdoor units	Equivalent length of all liquid pipes < 90m			Equivalent length of all liquid pipes ≥ 90m		
	Gas pipe (mm)	Liquid pipe (mm)	Branch joint kit	Gas pipe (mm)	Liquid pipe (mm)	Branch joint kit
8HP	Φ19.1	Φ9.53	FQZHN-02D	Φ22.2	Φ12.7	FQZHN-02D
10HP	Φ22.2	Φ9.53	FQZHN-02D	Φ25.4	Φ12.7	FQZHN-02D
12-14HP	Φ25.4	Φ12.7	FQZHN-02D	Φ28.6	Φ15.9	FQZHN-03D
16HP	Φ28.6	Φ12.7	FQZHN-03D	Φ31.8	Φ15.9	FQZHN-03D
18-24HP	Φ28.6	Φ15.9	FQZHN-03D	Φ31.8	Φ19.1	FQZHN-03D
26-34HP	Φ31.8	Φ19.1	FQZHN-03D	Φ38.1	Φ22.2	FQZHN-04D
36-54HP	Φ38.1	Φ19.1	FQZHN-04D	Φ41.3	Φ22.2	FQZHN-04D
56-66HP	Φ41.3	Φ19.1	FQZHN-05D	Φ44.5	Φ22.2	FQZHN-05D
68-82HP	Φ44.5	Φ22.2	FQZHN-05D	Φ54.0	Φ25.4	FQZHN-06D
84-96HP	Φ50.8	Φ25.4	FQZHN-05D	Φ54.0	Φ28.6	FQZHN-07D

Notes:

- The main pipe (L₁) and first indoor branch joint (A) should be sized according to whichever of Tables 3-4.4 and 3-4.5 indicates the larger size.

Figure 3-4.4: Outdoor connection pipes

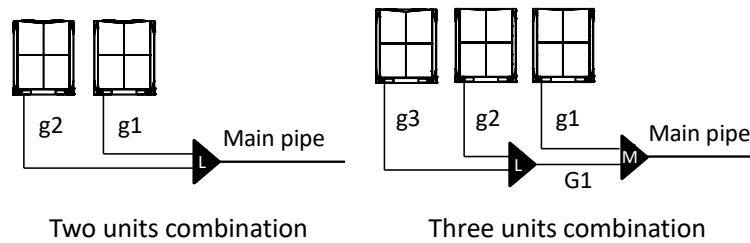
 Table 3-4.6: Outdoor connection pipes (g₁ to g₃, G₁)

Pipes	Outdoor unit capacity	Gas pipe (mm)	Liquid pipe (mm)
g ₁ to g ₃	8-12HP	Φ25.4	Φ12.7
	14-22HP	Φ31.8	Φ15.9
	24-32HP	Φ38.1	Φ19.1
G ₁		Φ41.3	Φ22.2

Table 3-4.7: Outdoor branch joint kits (L to M)

No. of outdoor units	Branch joint kit
2	FQZHW-02N1E
3	FQZHW-03N1E

Table 3-4.8: Indoor auxiliary pipes (a to q)

Capacity of indoor unit (kW)	Pipe length ≤ 10m		Pipe length > 10m ¹	
	Gas pipe (mm)	Liquid pipe (mm)	Gas pipe (mm)	Liquid pipe (mm)
≤ 4.5	Φ12.7	Φ6.35	Φ15.9	Φ9.53
≥ 5.6	Φ15.9	Φ9.53	Φ19.1	Φ12.7

Notes:

- An indoor auxiliary pipe should not be larger than the indoor main pipe immediately upstream of it. For indoor auxiliary pipes greater than 10m in length with indoor units of capacity greater than or equal to 5.6kW, the gas and liquid side pipes should each either be sized according to this table, or else be the same size as the indoor main pipe immediately upstream, whichever is smaller.

4.5 Refrigerant Piping Selection Example

The example below illustrates the piping selection procedure for a system consisting of three outdoor units (32HP + 22HP + 12HP) and 17 indoor units. The system's equivalent length of all liquid pipes is in excess of 90m; the piping between the farthest indoor unit and the first indoor branch joint is less than 40m in length; and each indoor auxiliary pipe (from each indoor unit to its nearest branch joint) is less than 10m in length.

Figure 3-4.4: Refrigerant piping selection example

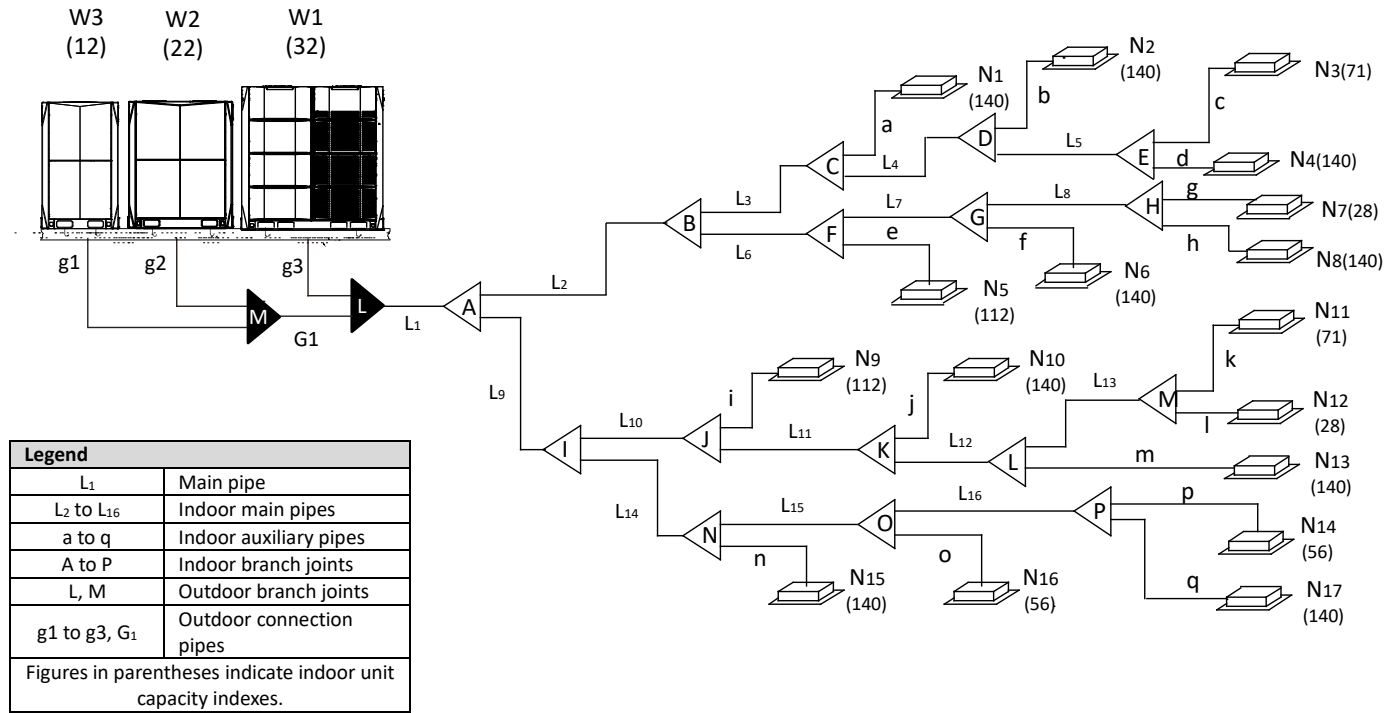

Step 1: Select indoor auxiliary pipes

- Indoor units N₁ to N₆, N₈ to N₁₁ and N₁₃ to N₁₇ are of capacity 5.6kW or greater and their indoor auxiliary pipes are less than 10m in length. Refer to Table 3-4.8. Indoor auxiliary pipes a to f, h to k, and m to q are $\Phi 15.9 / \Phi 9.53$.
- Indoor units N₇ and N₁₂ are of capacity less than 4.5kW and their indoor auxiliary pipes are less than 10m in length. Refer to Table 3-4.8. Indoor auxiliary pipes g and l are $\Phi 12.7 / \Phi 6.35$.

Step 2: Select indoor main pipes and indoor branch joints B to P

- The indoor units (N₃ and N₄) downstream of indoor branch joint E have total capacity of $14 + 7.1 = 21.1\text{kW}$. Refer to Table 3-4.4. Indoor main pipe L₅ is $\Phi 19.1 / \Phi 9.53$. Indoor branch joint E is FQZHN-01D.
- The indoor units (N₁ to N₈) downstream of indoor branch joint B have total capacity of $14 \times 5 + 11.2 + 7.1 + 2.8 = 91.1\text{kW}$. Refer to Table 3-4.4. Indoor main pipe L₂ is $\Phi 31.8 / \Phi 19.1$. Indoor branch joint B is FQZHN-03D.
- The other indoor main pipes and indoor branch joints are selected in the same fashion.

Step 3: Select main pipe and indoor branch joint A

- The indoor units (N₁ to N₁₇) downstream of indoor branch joint A have total capacity of $14 \times 9 + 11.2 \times 2 + 7.1 \times 2 + 5.6 \times 2 + 2.8 \times 2 = 179.4\text{kW}$. The system's equivalent length of all liquid pipes is in excess of 90m. The total capacity of the outdoor units is $32 + 22 + 12 = 66\text{HP}$. Refer to Tables 3-4.4 and 3-4.5. Main pipe L₁ is the larger of $\Phi 41.3 / \Phi 19.1$ and $\Phi 44.5 / \Phi 22.2$, hence $\Phi 44.5 / \Phi 22.2$. Indoor branch joint A is FQZHN-05D.

Step 4: Select outdoor connection pipes and outdoor branch joints

- The master unit is 32HP and the slave units are 22HP and 12HP. Refer to Table 3-4.6. Outdoor connection pipes g₁ is $\Phi 25.4 / \Phi 12.7$, g₂ is $\Phi 31.8 / \Phi 15.9$ and g₃ is $\Phi 38.1 / \Phi 19.1$.
- Refer to Table 3-4.6. Outdoor connection pipe G₁ is $\Phi 41.3 / \Phi 22.2$.
- There are three outdoor units in the system. Refer to Table 3-4.7. Outdoor branch joints L and M are FQZHW-03N1E.

4.6 Branch Joints

Branch joint design should take account of the following:

- U-shaped branch joints should be used – tee joints are not suitable. Branch joint dimensions are given in Tables 3-4.9 and 3-4.10.
- To avoid accumulation of oil in the outdoor units, outdoor branch joints should be installed horizontally and must not be higher than the outdoor unit refrigerant outlets. Refer to Figure 3-5.9 in Part 3, 5.6 “Branch Joints”. Indoor branch joints may be installed either horizontally or vertically.
- To ensure even distribution of refrigerant, branch joints should not be installed within 500mm of a 90° bend, another branch joint or the straight section of piping leading to an indoor unit, with the minimum 500mm being measured from the point where the branch joint is connected to the piping, as shown in Figure 3-4.5.

Figure 3-4.5: Branch joint spacing and separation from bends (unit: mm)

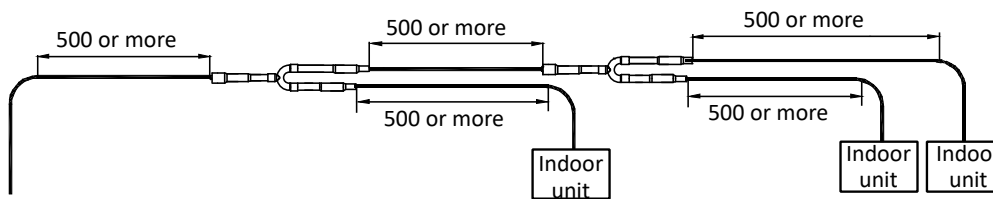

Table 3-4.9: Indoor branch joint dimensions (unit: mm)

Model	Gas side joints	Liquid side joints
FQZHN-01D		
FQZHN-02D		
FQZHN-03D		
FQZHN-04D		
FQZHN-05D		
FQZHN-06D		

Table 3-4.9: Indoor branch joint dimensions (unit: mm) (continued)

Model	Gas side joints	Liquid side joints
FQZHN-07D		

Table 3-4.10: Outdoor branch joint dimensions (unit: mm)

Model	Gas side joints	Liquid side joints
FQZHW-02N1E		
FQZHW-03N1E		

4.7 Refrigerant Leakage Precautions

R410A refrigerant is not flammable in air at temperatures up to 100°C at atmospheric pressure and is generally considered a safe substance to use in air conditioning systems. Nevertheless, precautions should be taken to avoid danger to life in the unlikely event of a major refrigerant leakage. Precautions should be taken in accordance with all applicable legislation.

Where no applicable legislation exists, the following may be used as a guide:

- Air conditioned rooms should be large enough that if leakage of all the refrigerant in the system occurs, the concentration of the refrigerant in the room does not reach a level dangerous to health.
- A critical concentration (at which point R410A becomes dangerous to human health) of 0.44 kg/m³ can be used.
- The potential concentration of refrigerant in a room following a leak can be calculated as follows:
 - Calculate the total amount in of refrigerant in the system (“A”) as the nameplate charge (the charge in the system when delivered from the factory) plus the additional charge added as per Part 3, 8.1 “Calculating Additional Refrigerant Charge”.
 - Calculate the total volume (“B”) of the smallest room into which refrigerant could potentially leak.
 - Calculate the potential refrigerant concentration as A divided by B.
 - If A/B is not less than 0.44 kg/m³, countermeasures such installing mechanical ventilators (either ventilating regularly or controlled by refrigerant leakage detectors) should be taken.
- Since R410A is heavier than air, particular consideration should be given to leak scenarios in basement rooms.

Figure 3-4.6: Potential refrigerant leak scenario

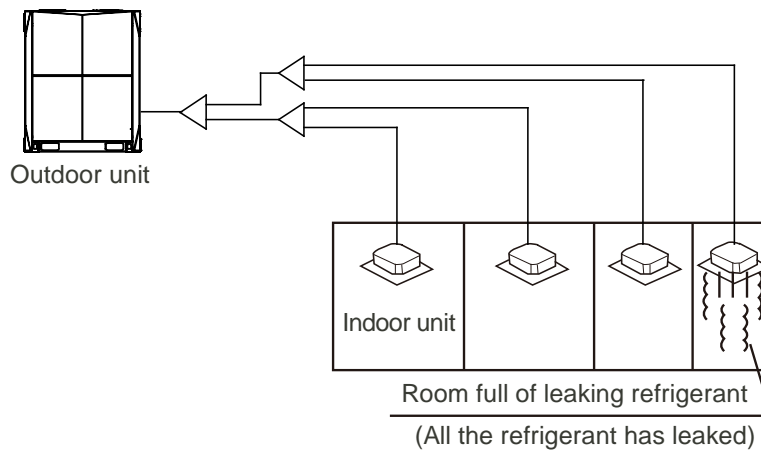
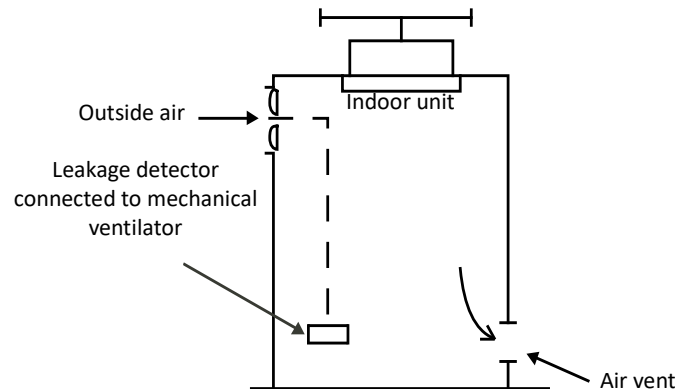

Figure 3-4.7: Mechanical ventilator controlled by refrigerant leak detector



5 Refrigerant Piping Installation

5.1 Procedure and Principles

5.1.1 Installation procedure

Notes for installers

Installation of the refrigerant piping system should proceed in the following order:

Pipe insulation

Pipe brazing and installation

Pipe flushing

Gastightness test

Joint insulation

Vacuum drying

Note: Pipe flushing should be performed once the brazed connections have been completed with the exception of the final connections to the indoor units. That is, flushing should be performed once the outdoor units have been connected but before the indoor units are connected.

5.1.2 Three principles for refrigerant piping

	Reasons	Measures
CLEAN	Particles such as oxide produced during brazing and/or building dust can lead to compressor malfunction	<ul style="list-style-type: none"> Seal piping during storage¹ Flow nitrogen during brazing² Pipe flushing³
DRY	Moisture can lead to ice formation or oxidization of internal components leading to abnormal operation or compressor damage	<ul style="list-style-type: none"> Pipe flushing³ Vacuum drying⁴
SEALED	Imperfect seals can lead to refrigerant leakage	<ul style="list-style-type: none"> Pipe manipulation⁵ and brazing² techniques Gastightness test⁶

Notes:

1. See Part 3, 5.2.1 "Pipe delivery, storage and sealing".
2. See Part 3, 5.5 "Brazing".
3. See Part 3, 5.8 "Pipe Flushing".
4. See Part 3, 5.10 "Vacuum Drying".
5. See Part 3, 5.3 "Manipulating Copper Piping".
6. See Part 3, 5.9 "Gastightness Test".

5.2 Storing Copper Piping

5.2.1 Pipe delivery, storage and sealing

Notes for installers



- Ensure that piping does not get bent or deformed during delivery or whilst stored.
- On construction sites store piping in a designated location.
- To prevent dust or moisture entering, piping should be kept sealed whilst in storage and until it is about to be connected. If piping is to be used soon, seal the openings with plugs or adhesive tape. If piping is to be stored for a long time, charge the piping with nitrogen at 0.2-0.5MPa and seal the openings by brazing.
- Storing piping directly on the ground risks dust or water ingress. Wooden supports can be used to raise piping off the ground.
- During installation, ensure that piping to be inserted through a hole in a wall is sealed to ensure dust and/or fragments of wall do not enter.
- Be sure to seal piping being installed outdoors (especially if being installed vertically) to prevent rain entering.

5.3 Manipulating Copper Piping

5.3.1 De-oiling

Notes for installers



- Lubrication oil used during some copper pipe manufacturing processes can cause deposits to form in R410A refrigerant systems, causing system errors. Oil-free copper piping should therefore be selected. If ordinary (oily) copper piping is used, it must be cleaned with gauze dipped in tetrachloroethylene solution prior to installation.

Caution

- Never use carbon tetrachloride (CCl₄) for pipe cleansing or flushing, as doing so will seriously damage the system.

5.3.2 Cutting copper piping and removing burrs

Notes for installers



- Use a pipe cutter rather than a saw or cutting machine to cut piping. Rotate the piping evenly and slowly, applying even force to ensure that the piping does not become deformed during cutting. Using a saw or cutting machine to cut piping runs the risk of copper shavings entering the piping. Copper shavings are difficult to remove and pose a serious risk to the system if they enter the compressor or block the throttling unit.
- After cutting using a pipe cutter, use a reamer/scrapper to remove any burrs that have formed at the opening, keeping the opening of the piping downwards to avoid copper shavings from entering the piping.
- Remove burrs carefully to avoid scratches, which may prevent a proper seal being formed and lead to refrigerant leakage.

5.3.3 Expanding copper piping ends

Notes for installers



- Ends of copper piping can be expanded so that another length of piping can be inserted and the joint brazed.
- Insert the expanding head of the pipe expander into the pipe. After completing pipe expansion, rotate the copper pipe a few degrees to rectify the straight line mark left by the expanding head.

Caution

- Ensure that the expanded section of piping is smooth and even. Remove any burrs that remain after cutting.

Figure 3-5.1: Expanding copper piping ends

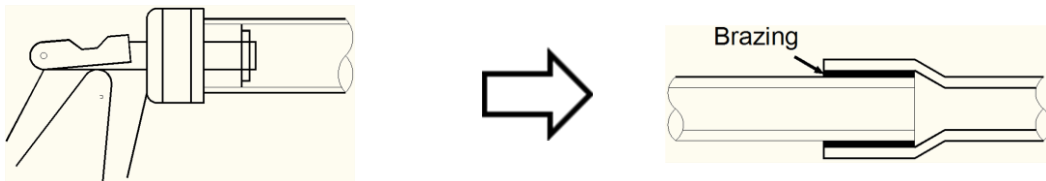

5.3.4 Flared joints

Flared joints should be used where a screw thread connection is required.

Notes for installers



- Before flaring 1/2H (half hard) piping, anneal the end of the pipe to be flared.
- Remember to place the flare nut on the piping before flaring.
- Ensure the flared opening is not cracked, deformed or scratched, otherwise it will not form a good seal and refrigerant leakage may occur.
- The diameter of the flared opening should be within the ranges specified in Table 3-5.1. Refer to Figure 3-5.2.

Table 3-5.1: Flared opening size ranges

Pipe (mm)	Flared opening diameter (A) (mm)
Φ6.35	8.7 - 9.1
Φ9.53	12.8 - 13.2
Φ12.7	16.2 - 16.6
Φ15.9	19.3 - 19.7
Φ19.1	23.6 - 24.0

Figure 3-5.2: Flared opening

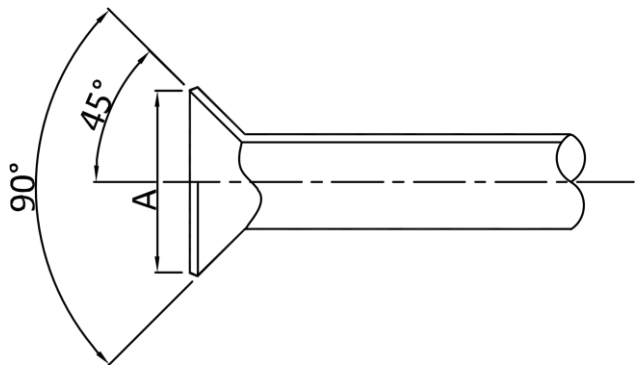

- When connecting a flared joint, apply some compressor oil to the inner and outer surfaces of the flared opening

5.3.5 Bending piping

Bending copper piping reduces the number of brazed joints required and can improve quality and save material.

Notes for installers



Piping bending methods

- Hand bending is suitable for thin copper piping ($\Phi 6.35\text{mm} - \Phi 12.7\text{mm}$).
- Mechanical bending (using a bending spring, manual bending machine or powered bending machine) is suitable for a wide range of diameters ($\Phi 6.35\text{mm} - \Phi 54.0\text{mm}$).

Caution

- When using a spring bender, ensure that the bender is clean before inserting it in the piping.
- After bending a copper pipe, ensure that there are no wrinkles or deformation on either side of the pipe.
- Ensure that bend angles do not exceed 90° , otherwise wrinkles may appear on the inner side of the pipe, and the pipe may buckle or crack. Refer to Figure 3-5.3.
- Do not use a pipe that has buckled during the bending process; ensure that the cross section at the bend is greater than $2/3$ of the original area.

Figure 3-5.3: Pipe bending in excess of 90°

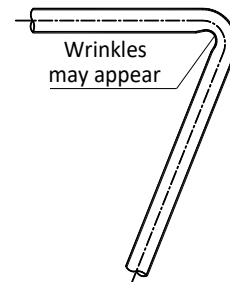

5.4 Refrigerant Piping Supports

When the air conditioning is running, the refrigerant piping will deform (shrink, expand, droop). To avoid damage to piping, hangers or supports should be spaced as per the criteria in the Table 3-5.2. In general, the gas and liquid pipes should be suspended in parallel and the interval between support points should be selected according to the diameter of the gas pipe.

Table 3-5.2: Refrigerant piping support spacings

Pipe (mm)	Interval between support points (m)	
	Horizontal Piping	Vertical Piping
$< \Phi 20$	1	1.5
$\Phi 20 - \Phi 40$	1.5	2
$> \Phi 40$	2	2.5

Suitable insulation should be provided between the piping and the supports. If wooden dowels or blocks are to be used, use wood that has undergone preservative treatment.

Changes in refrigerant flow direction and refrigerant temperature result in movement, expansion and shrinkage of the refrigerant piping. Piping should therefore not be fixed too tightly, otherwise stress concentrations may occur in the piping, with the potential for rupturing.

5.5 Brazing

Care must be taken to prevent oxide forming on the inside of copper piping during brazing. The presence of oxide in a refrigerant system adversely affects the operation of valves and compressors, potentially leading to low efficiency or even compressor failure. To prevent oxidation, during brazing nitrogen should be flowed through the refrigerant piping.

Notes for installers



Warning

- Never flow oxygen through piping as doing so aids oxidation and could easily lead to explosion and as such is extremely dangerous.
- Take appropriate safety precautions such as having a fire extinguisher to hand whilst brazing.

Flowing nitrogen during brazing

- Use a pressure reducing valve to flow nitrogen through copper piping at 0.02-0.03MPa during brazing.
- Start the flow before brazing starts and ensure that the nitrogen continuously passes through the section being brazed until the brazing is complete and the copper has cooled down completely.

Figure 3-5.4: Flowing nitrogen through piping during brazing

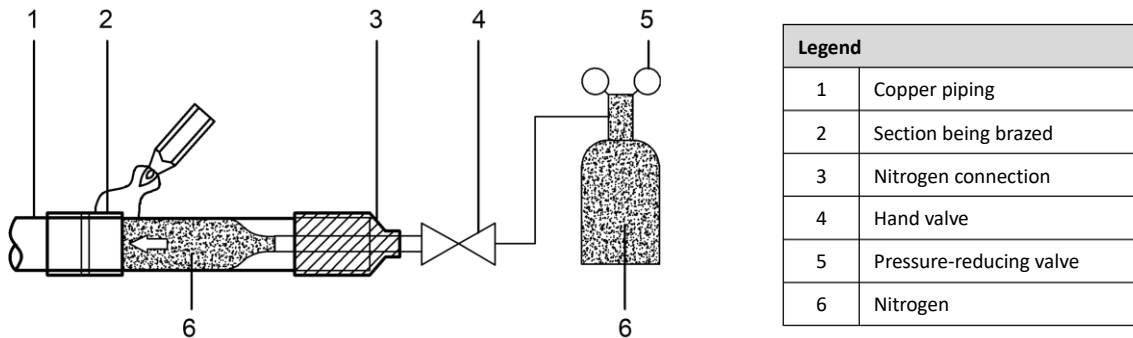

- When joining a shorter section of piping to a longer section, flow nitrogen from the shorter side to allow better displacement of air with nitrogen.
- If the distance from the point where nitrogen enters the piping to the joint to be brazed is long, ensure that the nitrogen is flowed for sufficient time to discharge all the air from the section to be brazed before commencing brazing.

Figure 3-5.5: Flowing nitrogen from shorter side during brazing

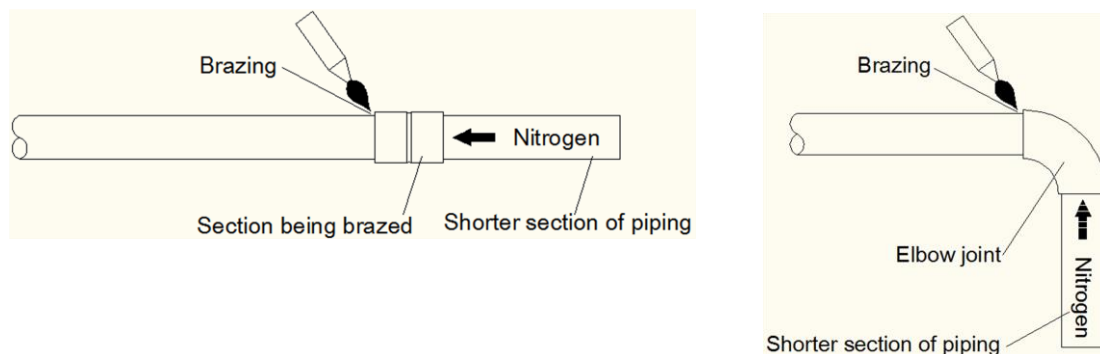

Box continued on next page ...

... box continued from previous page

Piping orientation during brazing

Brazing should be conducted downwards or horizontally to avoid filler leakage.

Figure 3-5.6: Piping orientation during brazing

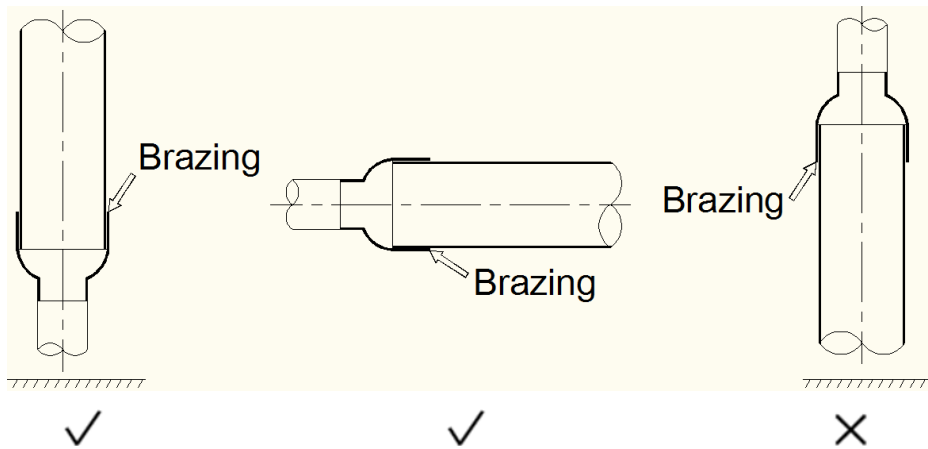

Piping overlap during brazing

Table 3-5.3 specifies the minimum permissible piping overlap and the range of permissible gap sizes for brazed joints on piping of different diameters. Refer also to Figure 3-5.7.

Figure 3-5.7: Piping overlap and gap for brazed joints

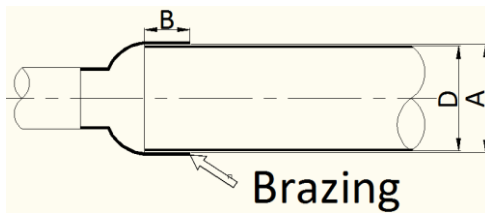

Legend	
A	Inner diameter of larger pipe
D	Outer diameter of smaller pipe
B	Inlaid depth (overlap)

Table 3-5.3: Piping overlap and gap for brazed joints¹

D (mm)	Minimum permissible B (mm)	Permissible A – D (mm)
5 < D < 8	6	0.05 - 0.21
8 < D < 12	7	
12 < D < 16	8	0.05 - 0.27
16 < D < 25	10	
25 < D < 35	12	0.05 - 0.35
35 < D < 45	14	

Notes:

1. A, B, D refer to the dimensions shown in Figure 3-5.7.

Filler

- Use a copper/phosphorus brazing alloy (BCuP) filler that does not require flux.
- Do not use flux. Flux can cause corrosion of piping and can affect the performance of compressor oil.
- Do not use anti-oxidants when brazing. Residue can clog piping and damage components.

5.6 Branch Joints

Notes for installers



- Use U-shaped branch joints as specified on the construction drawings – do not replace U-shaped branch joints with tee joints.
- To avoid accumulation of oil in the outdoor units, outdoor branch joints should be installed horizontally and must not be higher than the outdoor unit refrigerant outlets. Refer to Figure 3-5.9.
- Indoor branch joints may be installed either horizontally or vertically. Horizontal branch joints must be installed at an angle to the horizontal not exceeding 10° in order to avoid uneven distribution of refrigerant and possible malfunction. Refer to Figure 3-5.8.

Figure 3-5.8: Branch joint orientation

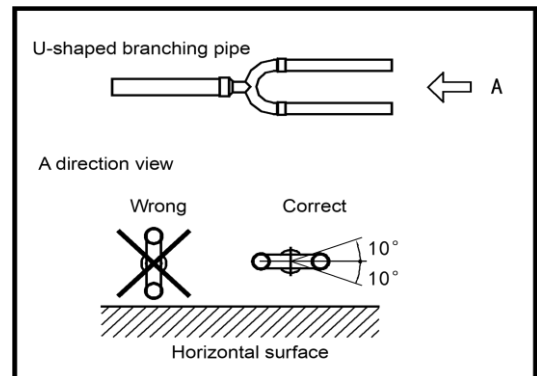
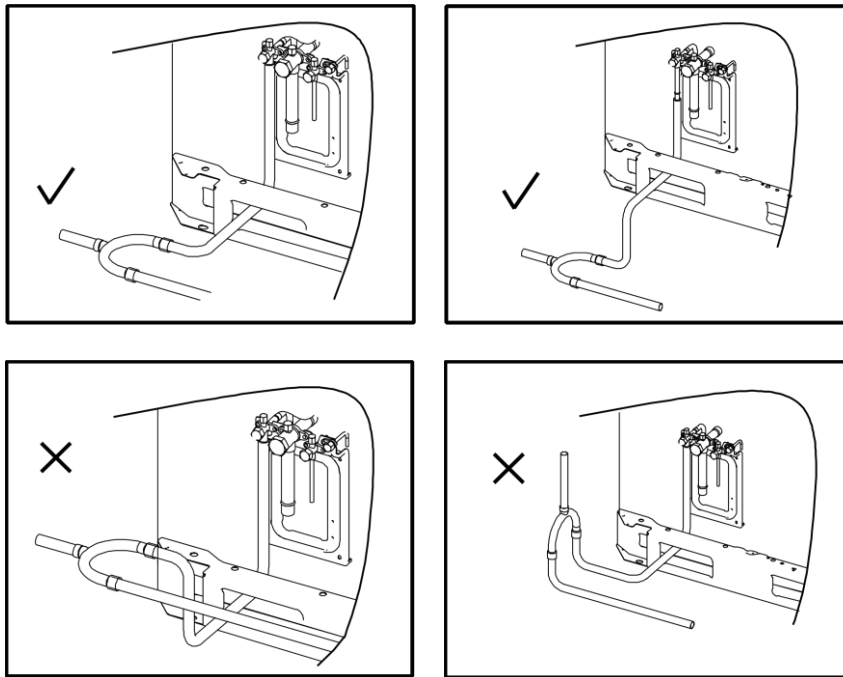

Figure 3-5.9: Installation of outdoor branch joints



- To ensure even distribution of refrigerant, a limitation is placed on how close branch joints may be installed to bends, other branch joints and the straight sections of piping leading to indoor units. Refer to Part 3, 4.6 “Branch Joints”.

5.7 Piping Connections between Outdoor Units

The piping connecting the outdoor units should be horizontal and must not be higher than the refrigerant outlets. If necessary, to avoid obstacles the piping may be vertically offset below the outlets. When inserting a vertical offset to avoid an obstacle, the whole outdoor piping should be offset, rather than just the section adjacent to the obstacle. Refer to Figure 3-5.10.

Figure 3-5.10: Piping connections between outdoor units

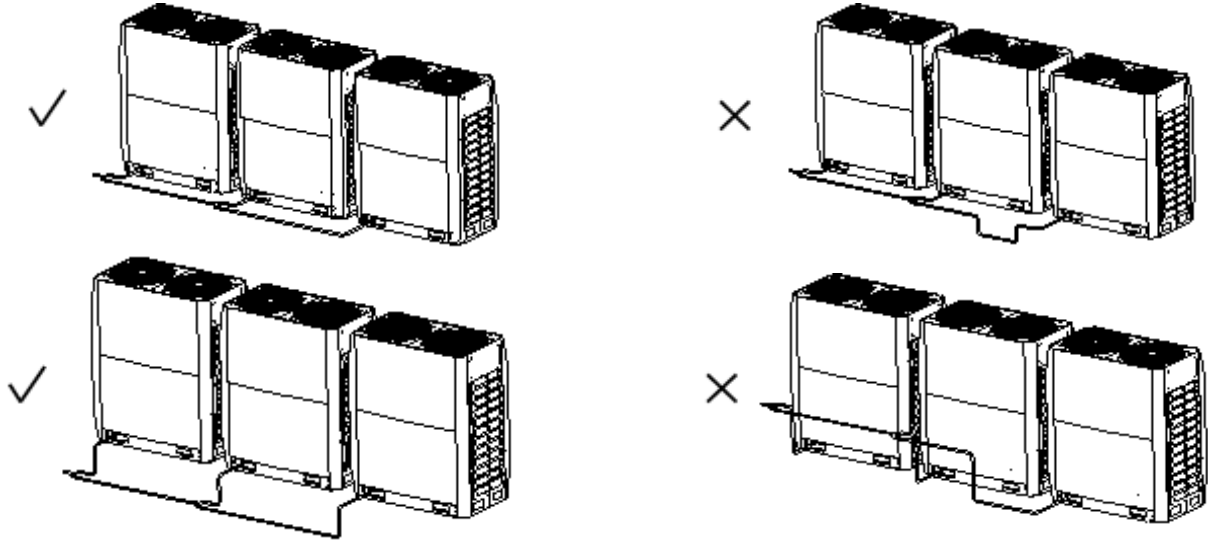

Outdoor piping should be installed in a metal casing to protect against exposure to sunlight, rain, wind and other potential causes of damage.

5.8 Pipe Flushing

5.8.1 Purpose

To remove dust, other particles and moisture, which could cause compressor malfunction if not flushed out before the system is run, the refrigerant piping should be flushed using nitrogen. As described in Part 3, 5.1.1 "Installation procedure", pipe flushing should be performed once the piping connections have been completed with the exception of the final connections to the indoor units. That is, flushing should be performed once the outdoor units have been connected but before the indoor units are connected.

5.8.2 Procedure

Notes for installers



Warning

Only use nitrogen for flushing. Using carbon dioxide risks leaving condensation in the piping. Oxygen, air, refrigerant, flammable gases and toxic gases must not be used for flushing. Use of such gases may result in fire or explosion.

Procedure

The liquid and gas sides can be flushed simultaneously; alternatively, one side can be flushed first and then Steps 1 to 8 repeated, for the other side. The flushing procedure is as follows:

1. Cover the inlets and outlets of the indoor units to prevent dirt getting blown in during pipe flushing. (Pipe flushing should be carried out before connecting the indoor units to the piping system.)
2. Attach a pressure reducing valve to a nitrogen cylinder.
3. Connect the pressure reducing valve outlet to the inlet on the liquid (or gas) side of the outdoor unit.
4. Use blind plugs to block all liquid (gas) side openings, except for the opening at the indoor unit which is furthest from the outdoor units ("Indoor unit A" in Figure 3-5.11).
5. Start to open the nitrogen cylinder valve and gradually increase the pressure to 0.5MPa.
6. Allow time for nitrogen to flow as far as the opening at indoor unit A.
7. Flush the first opening:
 - a) Using suitable material, such as a bag or cloth, press firmly against the opening at indoor unit A.
 - b) When the pressure becomes too high to block with your hand, suddenly remove your hand allowing gas to rush out.
 - c) Repeatedly flush in this manner until no further dirt or moisture is emitted from the piping. Use a clean cloth to check for dirt or moisture being emitted. Seal the opening once it has been flushed.
8. Flush the other openings in the same manner, working in sequence from indoor unit A towards the outdoor units. Refer to Figure 3-5.12.
9. Once flushing is complete, seal all openings to prevent dust and moisture from entering.

Figure 3-5.11: Pipe flushing using nitrogen

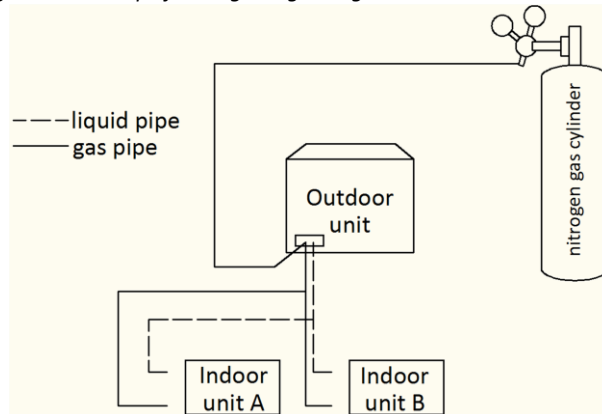
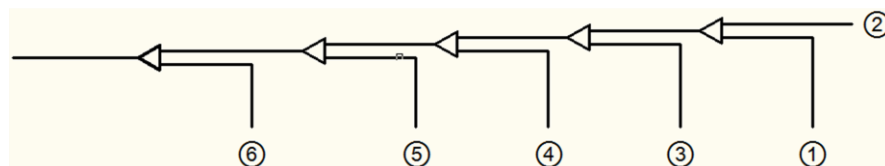

Figure 3-5.12: Pipe flushing sequence¹



Notes:

1. 1-2-3-4-5-6 working towards the outdoor units.

5.9 Gastightness Test

5.9.1 Purpose

To prevent faults caused by refrigerant leakage, a gastightness test should be performed before system commissioning..

5.9.2 Procedure

Notes for installers



Warning

Only dry nitrogen should be used for gastightness testing. Oxygen, air, flammable gases and toxic gases must not be used for gastightness testing. Use of such gases may result in fire or explosion.

Procedure

The gastightness test procedure is as follows:

Step 1

- Once the piping system is complete and the indoor and outdoor units have been connected, vacuum the piping to -0.1MPa.

Step 2

- Charge the indoor piping with nitrogen at 0.3MPa through the needle valves on the liquid and gas stop valves and leave for at least 3 minutes (do not open the liquid or gas stop valves). Observe the pressure gauge to check for large leakages. If there is a large leakage, the pressure gauge will drop quickly.
- If there are no large leakages, charge the piping with nitrogen at 1.5MPa and leave for at least 3 minutes. Observe the pressure gauge to check for small leakages. If there is a small leakage, the pressure gauge will drop distinctly.
- If there are no small leakages, charge the piping with nitrogen at 4MPa and leave for at least 24 hours to check for micro leakages. Micro leakages are difficult to detect. To check for micro leakages, allow for any change in ambient temperature over the test period by adjusting the reference pressure by 0.01MPa per 1°C of temperature difference. Adjusted reference pressure = Pressure at pressurization + (temperature at observation – temperature at pressurization) x 0.01MPa. Compare the observed pressure with the adjusted reference pressure. If they are the same, the piping has passed the gastightness test. If the observed pressure is lower than the adjusted reference pressure, the piping has a micro leakage.
- If the leakage is detected, refer to Part 3, 5.9.3 “Leak detection”. Once the leak has been found and fixed, the gastightness test should be repeated.

Step 3

- If not continuing straight to vacuum drying (see Part 3, 5.10 “Vacuum Drying”) once the gastightness test is complete, reduce the system pressure to 0.5-0.8MPa and leave the system pressurized until ready to carry out the vacuum drying procedure.

Figure 3-5.13: Gastightness test

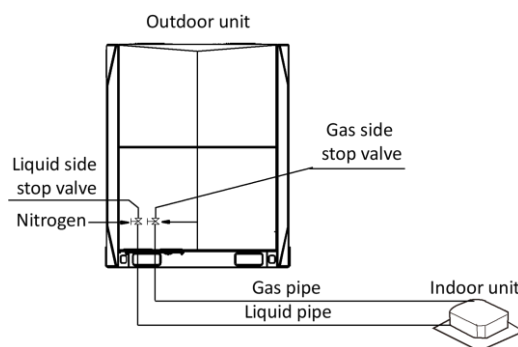

5.9.3 Leak detection

Notes for installers



The general methods for identifying the source of a leak are as follows:

1. Audio detection: relatively large leaks are audible.
2. Touch detection: place your hand at joints to feel for escaping gas.
3. Soapy water detection: small leaks can be detected by the formation of bubbles when soapy water is applied to a joint.
4. Refrigerant leak detection: for leaks that are difficult to detect, refrigerant leak detection may be used as follows:
 - a) Pressurize the piping with nitrogen at 0.3MPa.
 - b) Add refrigerant into the piping until the pressure reaches 0.5MPa.
 - c) Use a halogen refrigerant detector to find the leak.
 - d) If the leak source cannot be found, continuing charging with refrigerant to a pressure of 4MPa and then search again.

5.10 Vacuum Drying

5.10.1 Purpose

Vacuum drying should be performed in order to remove moisture and non-condensable gases from the system. Removing moisture prevents ice formation and oxidization of copper piping or other internal components. The presence of ice particles in the system would cause abnormal operation, whilst particles of oxidized copper can cause compressor damage. The presence of non-condensable gases in the system would lead to pressure fluctuations and poor heat exchange performance.

Vacuum drying also provides additional leak detection (in addition to the gastightness test).

5.10.2 Procedure

Notes for installers



During vacuum drying, a vacuum pump is used to lower the pressure in the piping to the extent that any moisture present evaporates. At 5mmHg (755mmHg below typical atmospheric pressure) the boiling point of water is 0°C. Therefore a vacuum pump capable of maintaining a pressure of -756mmHg or lower should be used. Using a vacuum pump with a discharge in excess of 4L/s and a precision level of 0.02mmHg is recommended.

Caution

- Before performing vacuum drying, make sure that all the outdoor unit stop valves are firmly closed.
- Once the vacuum drying is complete and the vacuum pump is stopped, the low pressure in the piping could suck vacuum pump lubricant into the air conditioning system. The same could happen if the vacuum pump stops unexpectedly during the vacuum drying procedure. Mixing of pump lubricant with compressor oil could cause compressor malfunction and a one-way valve should therefore be used to prevent vacuum pump lubricant seeping into the piping system.

Procedure

The vacuum drying procedure is as follows:

Step 1

- Connect the blue (low pressure side) hose of a pressure gauge to the master unit gas pipe stop valve, the red (high pressure side) hose to the master unit liquid pipe stop valve and the yellow hose to the vacuum pump.

Step 2

- Start the vacuum pump and then open the pressure gauge valves to start vacuum the system.
- After 30 minutes, close the pressure gauge valves.
- After a further 5 to 10 minutes check the pressure gauge. If the gauge has returned to zero, check for leakages in the refrigerant piping.

Step 3

- Re-open the pressure gauge valves and continue vacuum drying for at least 2 hours and until a pressure difference of 756mmHg or more has been achieved. Once the pressure difference of at least 756mmHg has been achieved, continue vacuum drying for 2 hours.

Step 4

- Close the pressure gauge valves and then stop the vacuum pump.
- After 1 hour, check the pressure gauge. If the pressure in the piping has not increased, the procedure is finished. If the pressure has increased, check for leakages.
- After vacuum drying, **keep the blue and red hoses connected to the pressure gauge and to the master unit stop valves**, in preparation for refrigerant charging (see Part 3, 8 “Charging Refrigerant”).

Figure 3-5.14: Vacuum drying

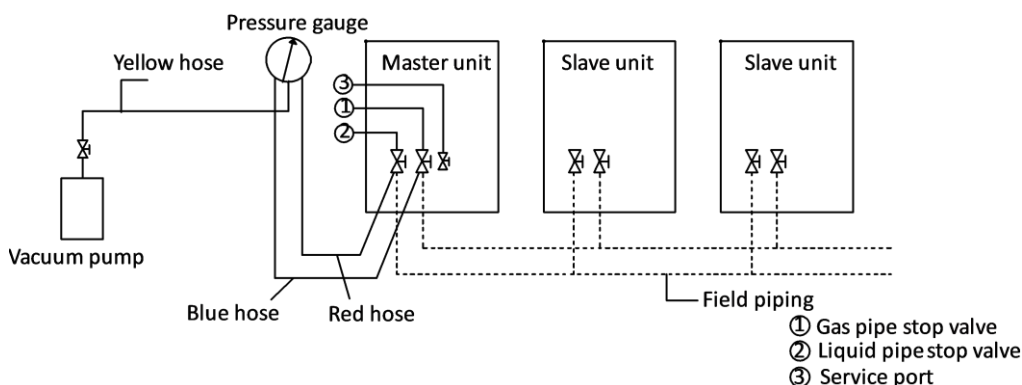

Pressure gauge

6 Drain Piping

6.1 Design Considerations

Drain piping design should take account of the following considerations:

- Indoor unit condensate drain piping needs to be of sufficient diameter to carry the volume of condensate produced at the indoor units and installed at a slope sufficient to allow drainage. Discharge as close as possible to the indoor units is usually preferable.
- To prevent the drain piping becoming excessively long, consideration should be given to installing multiple drain piping systems, with each system having its own drainage point and providing drainage for a subset of the overall set of indoor units.
- The routing of drain piping should take into consideration the need to maintain sufficient slope for drainage whilst avoiding obstacles such as beams and ducting. The drain piping slope should be at least 1:100 away from indoor units. Refer to Figure 3-6.1.

Figure 3-6.1: Drain piping minimum slope requirement

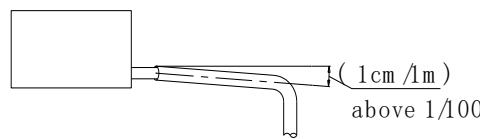

- To avoid backflow and other potential complications, two horizontal drain pipes should not meet at the same level. Refer to the Figure 3-6.2 for suitable connection arrangements. Such arrangements also allow the slope of the two horizontal pipes to be selected independently.

Figure 3-6.2: Drain piping joints – correct and incorrect configurations

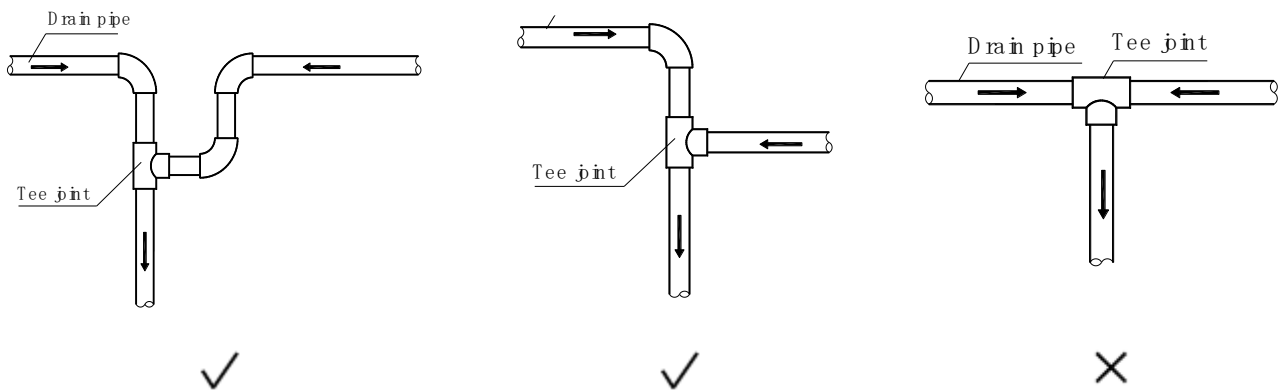

- Branch drain piping should join main drain piping from the top, as shown in Figure 3-6.3.
- Recommended support/hanger spacing is 0.8 – 1.0m for horizontal piping and 1.5 – 2.0m for vertical piping. Each vertical section should be fitted with at least two supports. For horizontal piping, spacing greater than those recommended leads to sagging and deformation of the pipe profile at the supports which impedes water flow and should therefore be avoided.
- Air vents should be fitted at the highest point of each drain piping system to ensure that condensation is discharged smoothly. U-bends or elbow joints should be used such that the vents face downwards, to prevent dust entering the piping. Refer to Figure 3-6.5. Air vents should not be installed too close to indoor unit lift pumps.

Figure 3-6.3: Branch drain piping joining main drain piping

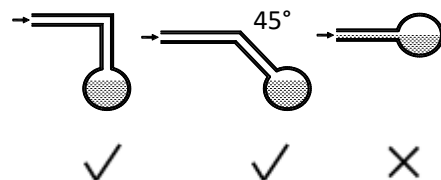

Figure 3-6.4: Effect of insufficient drain piping support

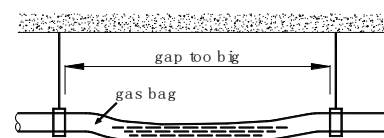
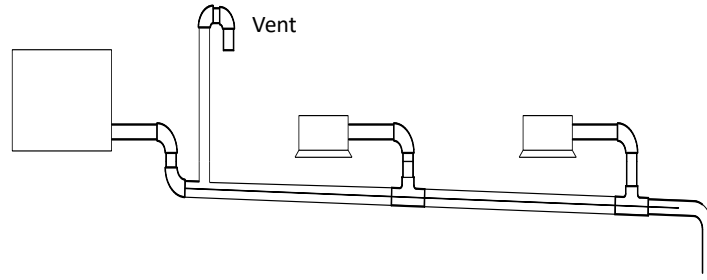

Figure 3-6.5: Drain piping air vents



- Air conditioner drain piping should be installed separately from waste, rainwater and other drain piping and should not come into direct contact with the ground.
- Drain piping diameter should be not less than the indoor units' drain piping connection.
- To allow inspection and maintenance, the piping clamps shipped with units should be used to attach drain piping to indoor units – adhesive should not be used.
- Thermal insulation should be added to drain piping to prevent condensation forming. Thermal insulation should extend all the way to the connection with the indoor unit.
- Units with drain pumps should have separate drain piping systems from systems that use natural drainage.

6.2 Water Traps

For indoor units with a high negative pressure differential at the outlet of the drainage pan, a trap should be fitted to the drain piping to prevent poor drainage and/or water being blown back into the drainage pan. Traps should be arranged as in Figure 3-6.6. The vertical separation H should be in excess of 50mm. A plug may be fitted to allow cleaning or inspection.

Figure 3-6.6: Drain piping water traps

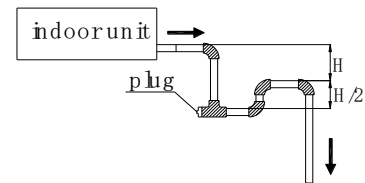

6.3 Selecting Piping Diameters

Select branch drainage piping (the drain piping connection to each unit) diameters according to indoor unit flow volume and select main drainage piping diameters according to the combined flow volume of the upstream indoor units. Use a design assumption of 2 liters of condensate per horsepower per hour. For example, the combined flow volume of three 2HP units and two 1.5HP units would be calculated as follows:

$$\begin{aligned} \text{Combined flow volume} &= 3 \times 2 \text{ L/HP/h} \times 2\text{HP} + 2 \times 2 \text{ L/HP/h} \times 1.5\text{HP} \\ &= 18 \text{ L/h} \end{aligned}$$

Tables 3-6.1 and 3-6.2 specify the required piping diameters for horizontal and vertical branch piping and for main piping. Note that main piping should use PVC40 or larger.

Table 3-6.1: Horizontal drain piping diameters

PVC piping	Nominal diameter (mm)	Capacity (L/h)		Remarks
		Slope 1:50	Slope 1:100	
PVC25	25	39	27	Branch piping only
PVC32	32	70	50	
PVC40	40	125	88	Branch or main piping
PVC50	50	247	175	
PVC63	63	473	334	

Table 3-6.2: Vertical drain piping diameters

PVC piping	Nominal diameter (mm)	Capacity (L/h)	Remarks
PVC25	25	220	Branch piping only
PVC32	32	410	
PVC40	40	730	
PVC50	50	1440	Branch or main piping
PVC63	63	2760	
PVC75	75	5710	
PVC90	90	8280	

6.4 Drain Piping for Units with Lift Pumps

Drain piping for units with lift pumps should take account of the following additional considerations:

- A downward sloping section should immediately follow the vertically rising section adjacent to the unit, otherwise a water pump error will occur. Refer to Figure 3-6.7.
- Air vents should not be installed on vertically rising sections of drain piping, otherwise water may be discharged through the air vent or water flow may be impeded.

Figure 3-6.7: Downward sloping section of drain piping

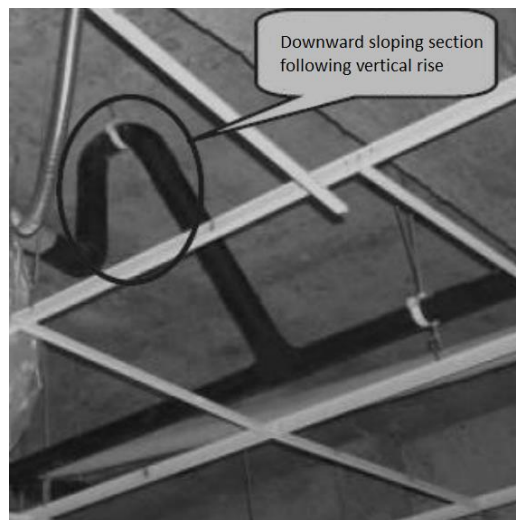

6.5 Drain Piping Installation

Notes for installers



Installation of the drain piping should proceed in the following order:



Caution

- Ensure that all joints are firm and once the drain piping is all connected conduct a watertightness test and water flow test.
- Do not connect air conditioner drain piping to waste, rainwater or other drain piping and do not let air conditioner drain piping come into direct contact with the ground.
- For units with drain pumps, test that the drain pump functions properly by adding water to the unit’s drainage pan and running the unit. To allow inspection and maintenance, the pipe clamps shipped with units should be used to attach drain piping to indoor units – adhesive should not be used.

6.6 Watertightness Test and Water Flow Test

Once installation of a drainage piping system is complete, watertightness and water flow tests should be performed.

Notes for installers



Watertightness test

- Fill the piping with water and test for leakages over a 24-hour period.

Water flow test (natural drainage test)

- Slowly fill the drainage pan of each indoor unit with at least 600ml of water through the inspection port and check that the water is discharged through the outlet of the drain piping.

Caution

- The drain plug in the drainage pan is for removing accumulated water prior to performing indoor unit maintenance. During normal operation, the drain should be plugged to prevent leakage.

7 Insulation

7.1 Refrigerant Piping Insulation

7.1.1 Purpose

During operation, the temperature of the refrigerant piping varies. Insulation is required to ensure unit performance and compressor lifespan. During cooling, the gas pipe temperature can be very low. Insulation prevents condensation forming on the piping. During heating, the gas pipe temperature can rise to as high as 100°C. Insulation serves as necessary protection from burns.

7.1.2 Selecting insulation materials

Refrigerant piping insulation should be closed-cell foam of B1 fire resistance rating that can withstand a constant temperature of over 120°C and that complies with all applicable legislation.

7.1.3 Thickness of insulation

Minimum thicknesses for refrigerant piping insulation are specified in Table 3-7.1. In hot, humid environments, the thickness of insulation should be increased over and above the specifications in Table 3-7.1.

Table 3-7.1: Refrigerant piping insulation thickness

Pipe outer diameter (mm)	Minimum insulation thickness (mm) Humidity < 80%RH	Minimum insulation thickness (mm) Humidity ≥ 80%RH
Φ6.35	15	20
Φ9.53		
Φ12.7		
Φ15.9		
Φ19.1		
Φ22.2		
Φ25.4		
Φ28.6		
Φ31.8		
Φ38.1		
Φ41.3	20	25
Φ44.5		
Φ54.0		

7.1.4 Installation of piping insulation

With the exception of joint insulation, insulation should be applied to piping before fixing the piping in place. Insulation at joints in refrigerant piping should be applied after the gastightness test has been completed.

Notes for installers



- Installation of insulation should be carried out in a manner suited to the type of insulation material being used.
- Ensure there are no gaps at the joints between sections of insulation.
- Do not apply tape too tightly as doing so may shrink insulation, reducing its insulating properties leading to condensation and loss of efficiency.
- Insulate gas and liquid pipes separately, otherwise heat exchange between the two sides will greatly impact efficiency.
- Do not bind the separately insulated gas and liquid pipes together too tightly as doing so can damage the joints between sections of insulation.

7.1.5 Installation of joint insulation

Insulation at joints in the refrigerant piping should be installed after the gastightness test has been successfully completed.

The procedure at each joint is as follows:

1. Cut a section of insulation 50 to 100mm longer than the gap to be filled. Ensure that the cross-sectional and longitudinal openings are all cut evenly.
2. Embed the section into the gap ensuring that the ends abut tightly to the sections of insulation either side of the gap.
3. Glue the longitudinal cut and the joints with the sections of insulation either side of the gap.
4. Seal the seams with tape.

Figure 3-7.1: Installation of joint insulation (unit: mm)

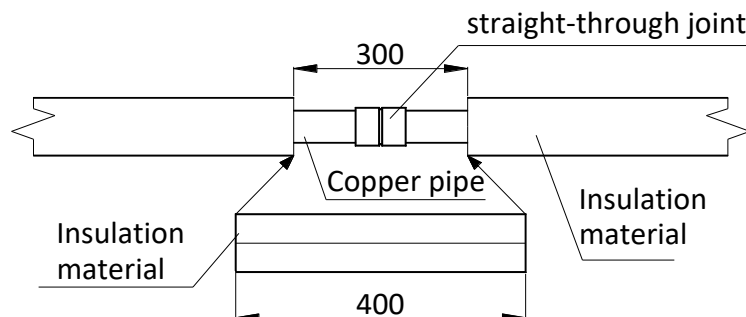

7.2 Drain Piping Insulation

- Use rubber/plastic insulating tube with a B1 fire resistance rating.
- The insulation should typically be in excess of 10mm thick.
- For drain piping installed inside a wall, insulation is not required.
- Use suitable adhesive to seal seams and joints in the insulation and then bind with cloth reinforced tape of width not less than 50mm. Ensure tape is fixed firmly to avoid condensation.
- Ensure the drain piping insulation adjacent to the indoor unit drainage water outlet is fixed to the unit itself using adhesive, to prevent condensation and dripping.

7.3 Ducting Insulation

- Suitable insulation should be added to ducting in according with all applicable legislation.

8 Charging Refrigerant

8.1 Calculating Additional Refrigerant Charge

The additional refrigerant charge required depends on the lengths and diameters of the outdoor and indoor liquid pipes. Table 3-8.1 shows the additional refrigerant charge required per meter of equivalent pipe length for different diameters of pipe. The total additional refrigerant charge is obtained by summing the additional charge requirements for each of the outdoor and indoor liquid pipes, as in the following formula, where L_1 to L_8 represent the equivalent lengths of the pipes of different diameters. Assume 0.5m for the equivalent pipe length of each branch joint.

$$\begin{aligned}
 \text{Additional refrigerant charge R (kg)} &= L_1 (\Phi 6.35) \times 0.022 \\
 &+ L_2 (\Phi 9.53) \times 0.057 \\
 &+ L_3 (\Phi 12.7) \times 0.110 \\
 &+ L_4 (\Phi 15.9) \times 0.170 \\
 &+ L_5 (\Phi 19.1) \times 0.260 \\
 &+ L_6 (\Phi 22.2) \times 0.360 \\
 &+ L_7 (\Phi 25.4) \times 0.520 \\
 &+ L_8 (\Phi 28.6) \times 0.680
 \end{aligned}$$

Table 3-8.1: Additional refrigerant charge

Liquid side piping (mm)	Additional refrigerant charge per meter of equivalent length of piping (kg)
Φ6.35	0.022
Φ9.53	0.057
Φ12.7	0.110
Φ15.9	0.170
Φ19.1	0.260
Φ22.2	0.360
Φ25.4	0.520
Φ28.6	0.680

8.2 Adding Refrigerant

Notes for installers



Caution

- Only charge refrigerant after performing a gastightness test and vacuum drying.
- Never charge more refrigerant than required as doing so can lead to liquid hammering.
- Only use refrigerant R410A - charging with an unsuitable substance may cause explosions or accidents.
- Use tools and equipment designed for use with R410A to ensure required pressure resistance and to prevent foreign materials from entering the system.
- Refrigerant must be treated in accordance with applicable legislation.
- Always use protective gloves and protect your eyes when charging refrigerant.
- Open refrigerant containers slowly.

Procedure

The procedure for adding refrigerant is as follows:

Step 1

- Calculate additional refrigerant charge R (kg) (see Part 3, 8.1 "Calculating Additional Refrigerant Charge")

Step 2

- Place a tank of R410A refrigerant on a weighing scale. Turn the tank upside down to ensure refrigerant is charged in a liquid state. (R410A is a blend of two different chemicals compounds. Charging gaseous R410A into the system could mean that the refrigerant charged is not of the correct composition).
- After vacuum drying (see Part 3, 5.10 "Vacuum Drying"), the blue and red pressure gauge hoses should still be connected to the pressure gauge and to the master unit stop valves.
- Connect the yellow hose from the pressure gauge to the R410A refrigerant tank.

Box continued on next page ...

... box continued from previous page

Step 3

- Open the valve where the yellow hose meets the pressure gauge, and open the refrigerant tank slightly to let the refrigerant eliminate the air. Caution: open the tank slowly to avoid freezing your hand.
- Set the weighing scale to zero.

Step 4

- Open the three valves on the pressure gauge to begin charging refrigerant.
- When the amount charged reaches R (kg), close the three valves. If the amount charged has not reached R (kg) but no additional refrigerant can be charged, close the three valves on the pressure gauge, run the outdoor units in cooling mode, and then open the yellow and blue valves. Continue charging until the full R (kg) of refrigerant has been charged, then close the yellow and blue valves. Note: Before running the system, be sure to complete all the pre-commissioning checks as listed in Part 3, 11.3 “Pre-commissioning Checks” and be sure to open all stop valves as running the system with the stop valves closed would damage the compressor.

Figure 3-8.1: Charging refrigerant

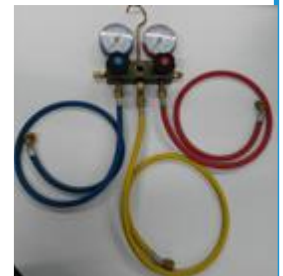
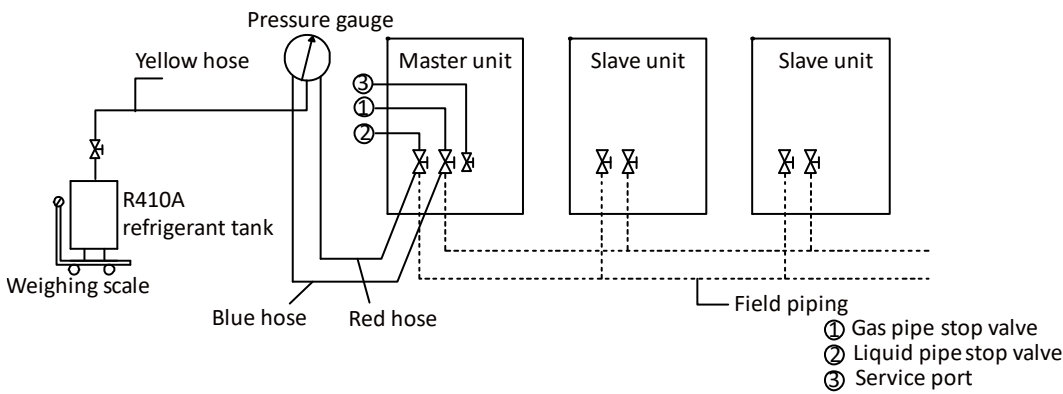

Pressure gauge

9 Electrical Wiring

9.1 General

Notes for installers



Caution

- All installation and wiring must be carried out by competent and suitably qualified, certified and accredited professionals and in accordance with all applicable legislation.
- Electrical systems should be grounded in accordance with all applicable legislation.
- Overcurrent circuit breakers and residual-current circuit breakers (ground fault circuit interrupters) should be used in accordance with all applicable legislation.
- Wiring patterns shown in this data book are general connection guides only and are not intended for, or to include all details for, any specific installation.
- The refrigerant piping, power wiring and communication wiring are typically run in parallel. However the communication wiring should not be bound together with the refrigerant piping or power wiring. To prevent signal interference, the power wiring and communication wiring should not be run in the same conduit. If the power supply is less than 10A, a separation of at least 300mm between power wiring and communication wiring conduits should be maintained; if the power supply is in the range 10A to 50A then a separation of at least 500mm should be maintained.

9.2 Power Supply Wiring

Power supply wiring design and installation should adhere to the following requirements:

- Separate power supplies should be provided for the indoor units and outdoor units.
- Where five or more outdoor units are installed, additional residual current protection (leakage protection) should be installed as shown in Figure 3-9.1.
- All the indoor units in a system (i.e. all the indoor units connected to the same set of outdoor units) should be tied into the same power circuit with the same power supply, overcurrent and residual current protection (leakage protection) and manual switch, as shown in Figure 3-9.2. Do not install separate protectors or manual switches for each indoor unit. Powering on and shutting down all indoor units in a system should be done simultaneously. The reason for this is that if an indoor unit that is running were to suddenly power off whilst the other indoor units continued running, the evaporator of the powered-off unit would freeze since refrigerant would continue flowing to that unit (its expansion valve would still be open) but its fan would have stopped. The indoor units that remain running would not get sufficient refrigerant so their performance would suffer. Additionally, liquid refrigerant returning directly to the compressor from the powered-off unit would cause liquid hammering, potentially damaging the compressor.
- For outdoor unit power wire sizing and circuit breaker sizing, refer to Table 2-6.1 in Part 2, 6 "Electrical Characteristics".

Figure 3-9.1: Outdoor unit power supply wiring

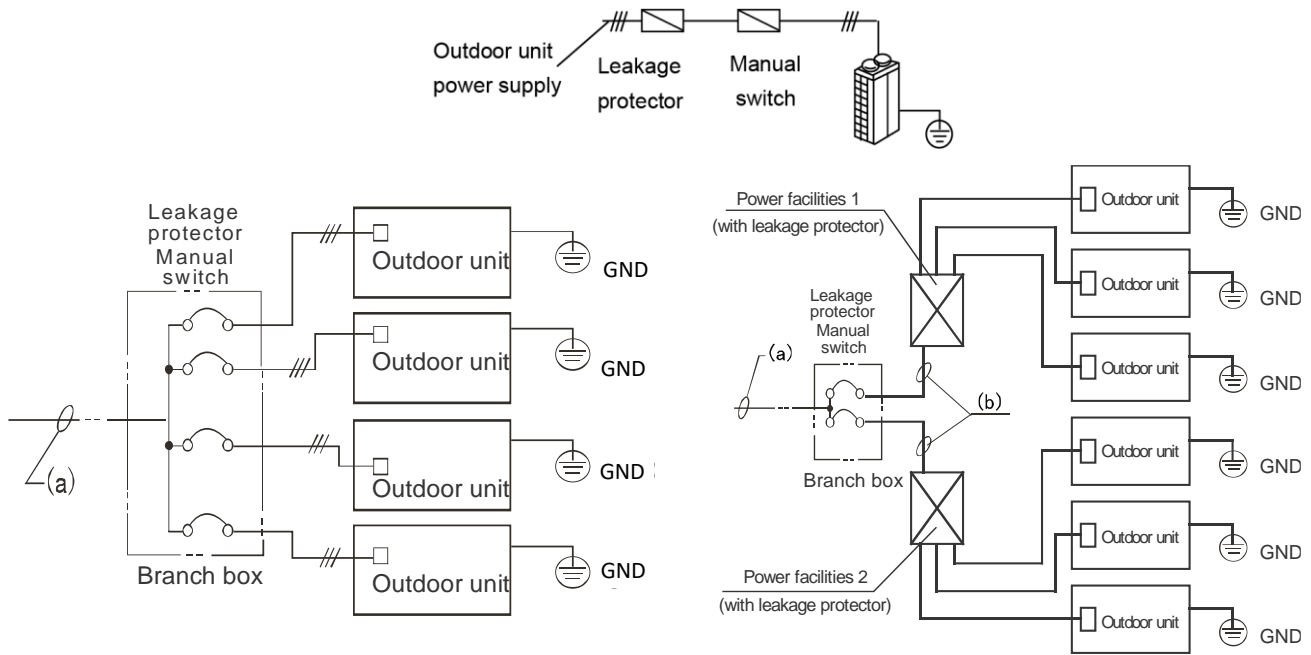
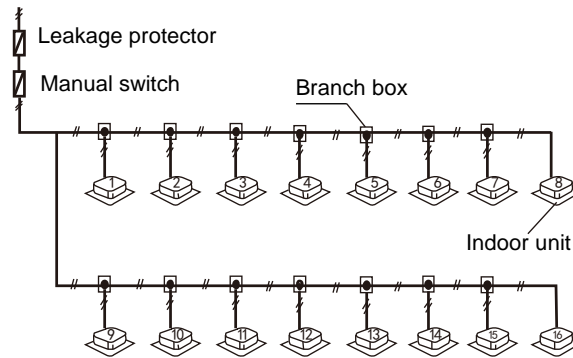

Figure 3-9.2: Indoor unit power supply wiring



Notes for installers



The 3-phase, 380-415V, 50 or 60Hz power supply should be connected to the outdoor unit power supply terminals as shown in Figure 3-9.3.

Figure 3-9.3: Outdoor unit 3-phase power supply terminals

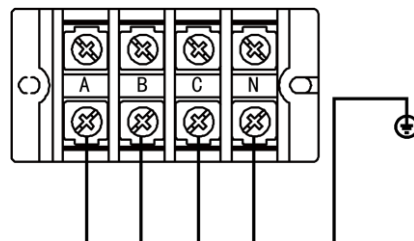

9.3 Communication Wiring

Communication wiring design and installation should adhere to the following requirements:

- 0.75mm² three-core shielded cable should be used for communication wiring. Using other types of cable can lead to interference and malfunction.

Indoor communication wiring:

- The P Q E communication wires should be connected one unit after another in a daisy chain from the outdoor unit to the final indoor unit as shown in Figure 3-9.4. At the final indoor unit, a 120Ω resistor should be connected between the P and Q terminals. After the final indoor unit, the communication wiring should NOT be continued back to the outdoor unit – that is, do not attempt to form a closed loop.
- The P and Q communication wires should NOT be grounded.
- The shielding nets of the communication wires should be connected together and grounded. Grounding can be achieved by connecting to the metal casing adjacent to the P Q E terminals of the outdoor unit electrical control box.

Outdoor communication wiring:

- The H1 H2 E communication wires should be connected one unit after another in a daisy chain from the master outdoor unit to the final slave outdoor unit as shown in Figure 3-9.4.

Figure 3-9.4: Communication wiring configurations – correct and incorrect examples

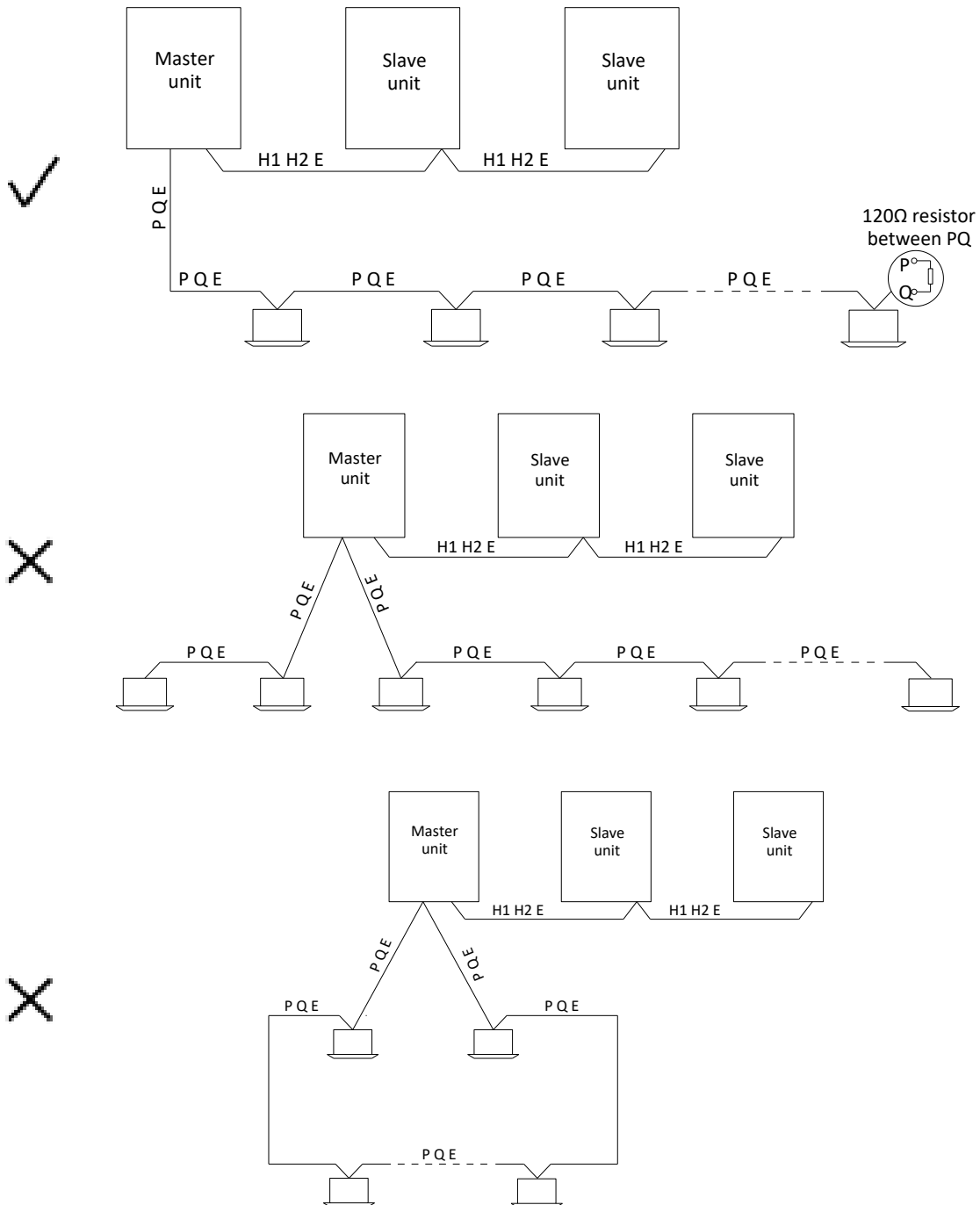

Notes for installers



The communication wires should be connected to the master outdoor unit terminals indicated in Figure 3-9.5 and Table 3-9.1.

Caution

- Communication wiring has polarity. Care should be taken to connect the poles correctly.

Figure 3-9.5: Master outdoor unit communication terminals

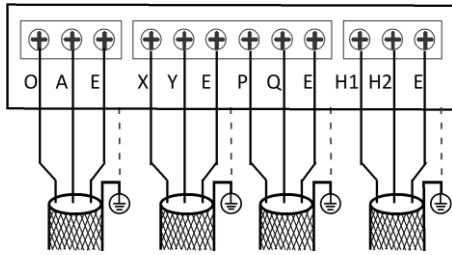
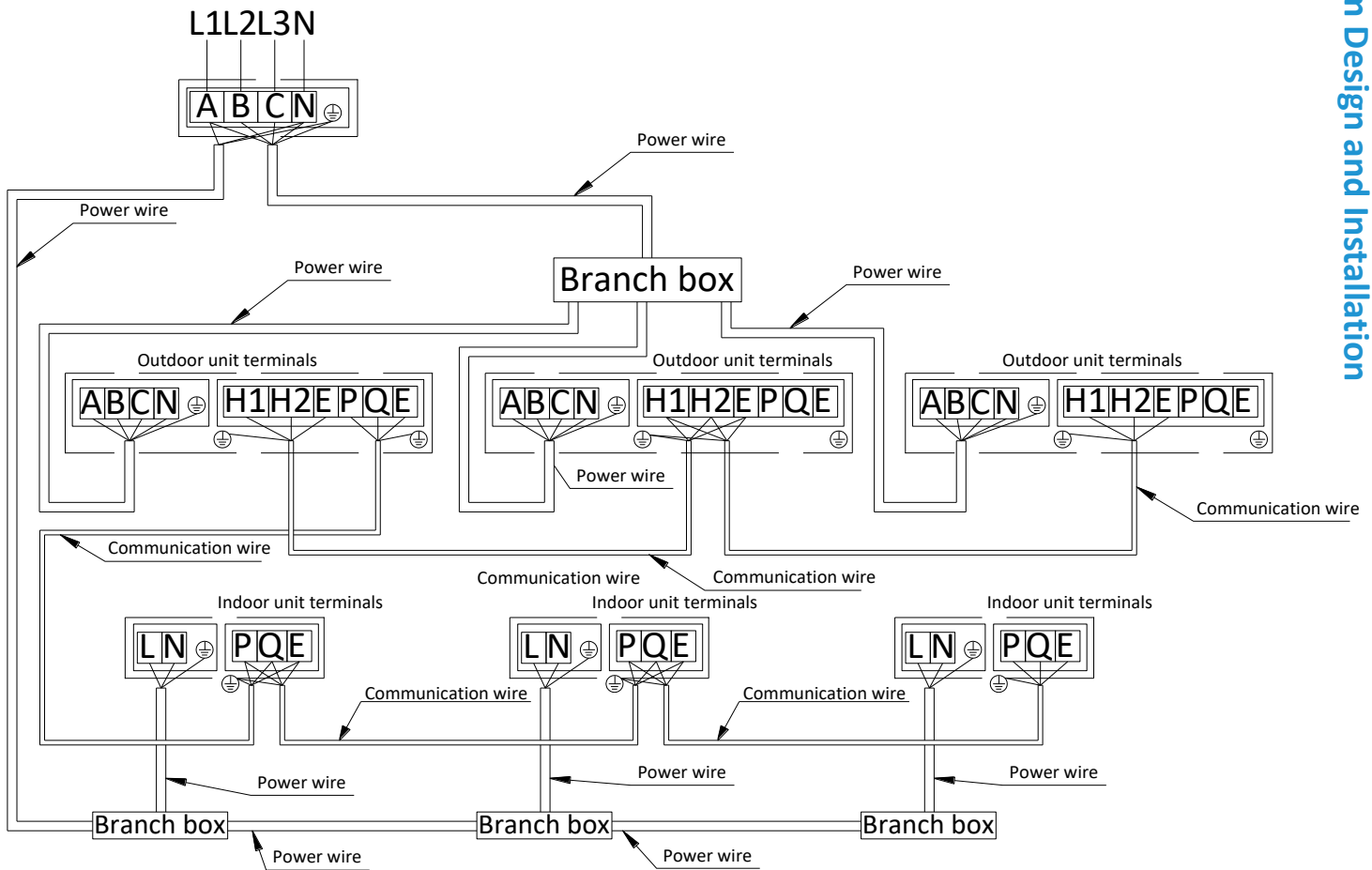

Table 3-9.1: Communication connections

Terminals	Connection
O A E	Connect to digital energy meter
X Y E	Connect to centralized controller
P Q E	Connect between indoor units and master outdoor unit
H1 H2 E	Connect between outdoor units

9.4 Wiring example

Figure 3-9.6: System power and communication wiring example



10 Installation in Areas of High Salinity

10.1 Caution

Do not install outdoor units where they could be directly exposed to sea air. Corrosion, particularly on the condenser and evaporator fins, could cause product malfunction or inefficient performance.

Outdoor units installed in seaside locations should be placed such as to avoid direct exposure to the sea air and additional anticorrosion treatment options should be selected, otherwise the service life of the outdoor units will be seriously affected.

Air conditioning installed in seaside locations should be run regularly as the running of the outdoor unit fans helps prevent build-up of salt on the outdoor unit heat exchangers.

10.2 Placement and Installation

Outdoor units should be installed 300m or more from the sea. If possible, well-ventilated indoor locations should be chosen. (When installing outdoor units indoors, outdoor unit discharge ducts should be added. See Part 3, 3 “Outdoor Unit Ducting and Shielding”.) Refer to Figure 3-10.1. If it is necessary to install outdoor units outside, direct exposure to the sea air should be avoided. A canopy should be added to shield the units from sea air and rain, as shown in Figure 3-10.2.

Ensure that base structures drain well so that outdoor unit footings do not become waterlogged. Check that outdoor unit casing drainage holes are not blocked.

Figure 3-10.1: Installation in a well-ventilated indoor area

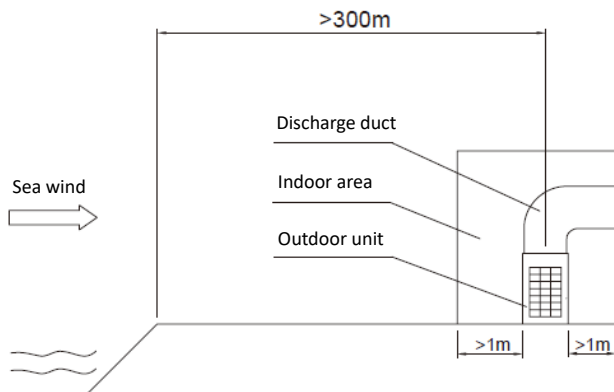
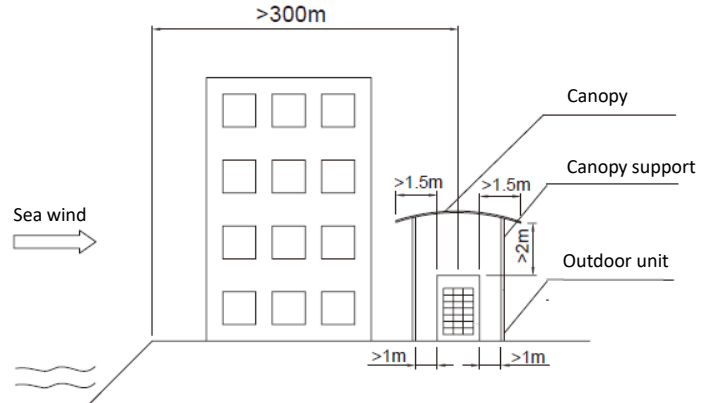

Figure 3-10.2: Installation outdoors under a canopy



10.3 Inspection and maintenance

In addition to standard outdoor unit servicing and maintenance, the following additional inspections and maintenance should be undertaken for outdoor units installed in seaside locations:

- A comprehensive post-installation inspection should check for any scratches or other damage to painted surfaces and any damaged areas should be repainted/repaired immediately.
- The units should be regularly cleaned using (non-salty) water to remove any salt that has accumulated. Areas cleaned should include the condenser, the refrigerant piping system, the outside surface of the unit casing and the outside surface of the electric control box.
- Regular inspections should check for corrosion and if necessary corroded components should be replaced and/or anti-corrosion treatments should be added.

11 Commissioning

11.1 Outdoor Unit Address and Capacity Settings

Before running a system for the first time, set each outdoor unit's address on switch ENC1 on each outdoor unit's main PCB. Refer to Table 3-11.1. The capacity of each outdoor unit (on switch ENC2 on each outdoor unit's main PCB) is factory-set and should not need changing. Check that the capacity settings are correct. Refer to Table 3-11.1.

Table 3-11.1: Outdoor unit address and capacity settings

Address settings		Capacity settings				
0	Master unit	0	8HP		7	22HP
1	Slave unit 1	1	10HP		8	24HP
2	Slave unit 2	2	12HP		9	26HP
3	Slave unit 3	3	14HP		A	28HP
≥4	Invalid	4	16HP		B	30HP
		5	18HP		C	32HP
		6	20HP			

11.2 Multi-system Projects

For projects with multiple refrigerant systems, each independent refrigeration system (i.e. each system of up to three outdoor units and their connected indoor units) should be given a test run independently, before the multiple systems that make up a project are run simultaneously.

11.3 Pre-commissioning Checks

Before turning on the power to the indoor and outdoor units, ensure the following:

1. All indoor and outdoor refrigeration piping and communication wiring has been connected to the correct refrigeration system and the system to which each indoor and outdoor unit belongs is clearly marked on each unit or recorded in some other suitable place.
2. Pipe flushing, gastightness testing and vacuum drying have been satisfactorily completed as per instructions.
3. All condensate drain piping is complete and a watertightness test has been satisfactorily completed.
4. All power and communication wiring is connected to the correct terminals on units and controllers. (Check that the different phases of the 3-phase power supplies have been connected to the correct terminals).
5. No wiring has been connected in a short-circuit.
6. The power supplies to indoor and outdoor units have been checked and the power supply voltages are within ±10% of the rated voltages for each product.
7. All control wiring is 0.75mm² three-core shielded cable and the shielding has been grounded.
8. The outdoor units' address and capacity switches are set correctly (see Part 3, 11.1 "Outdoor Unit Address and Capacity Settings") and all other indoor and outdoor unit field settings have been set as required.
9. The additional refrigerant charge has been added as per Part 3, 8 "Charging Refrigerant". Note: In some circumstances it may be necessary to run the system in cooling mode during the refrigerant charging procedure. In such circumstances, points 1 to 8 above should be checked before running the system for the purpose of charging refrigerant and the outdoor unit liquid, gas and oil balance valves should be opened.

During commissioning, it is important that you:

- Keep a supply of R410A refrigerant at hand.
- Keep the system layout, system piping and control wiring diagrams at hand.

11.4 Commissioning Trial Runs

11.4.1 Commissioning test run of single refrigerant system

Once all the pre-commissioning checks in Part 3, 11.3 “Pre-commissioning Checks” have been completed, a test run should be performed as described below and a V6 Series System Commissioning Report (see Part 3, 12 “Appendix to Part 3 – System Commissioning Report”) should be completed as a record of the operating status of the system during commissioning.

Note: When running the system for commissioning test runs, if the combination ratio is 100% or less, run all the indoor units and if the combination ratio is more than 100%, run indoor units with total capacity equal to the total capacity of the outdoor units.

The test run procedure is as follows:

1. Open the outdoor unit liquid and gas stop valves.
2. Turn on the power to the outdoor units.
3. If manual addressing is being used, set the addresses of each indoor unit.
4. Leave the power on for a minimum of 12 hours prior to running the system to ensure that the crankcase heaters have heated the compressor oil sufficiently.
5. Run the system:
 - a) Run the system in cooling mode with the following settings: temperature 17°C; fan speed high.
 - b) After one hour, complete Sheet A of the system commissioning report then check the system parameters using the UP/DOWN button on each outdoor unit’s main PCB and complete the cooling mode columns of one Sheet D and one Sheet E of the system commissioning report for each outdoor unit.
 - c) Run the system in heating mode with the following settings: temperature 30°C; fan speed high.
 - d) After one hour, complete Sheet B of the system commissioning report then check the system parameters using the UP/DOWN button on each outdoor unit’s main PCB and complete the heating mode columns of one Sheet D and one Sheet E of the system commissioning report for each outdoor unit.
6. Finally, complete Sheet C of the system commissioning report.

11.4.2 Commissioning test run of multiple refrigerant systems

Once the commissioning test run of each refrigerant system has been satisfactorily completed as per Part 3, 11.4.1 “Commissioning test run of single refrigerant system”, run the multiple systems that make up a project simultaneously and check for any abnormalities.

12 Appendix to Part 3 – System Commissioning Report

A total of up to 11 report sheets should be completed for each system:

- One Sheet A, one Sheet B and one Sheet C per system.
- One Sheet D and one Sheet E per outdoor unit.

V6 Series System Commissioning Report – Sheet C

Project name and location	System name
---------------------------	-------------

RECORD OF ISSUES SEEN DURING COMMISSIONING				
No.	Description of observed issue	Suspected cause	Troubleshooting undertaken	Serial no. of relevant unit
1				
2				
3				

OUTDOOR UNIT FINAL CHECKLIST				
	Master unit	Slave unit 1	Slave unit 2	Slave unit 3
SW2 system check performed?				
Any abnormal noise?				
Any abnormal vibration?				
Fan rotation normal?				

	Commissioning engineer	Dealer	Midea representative
Name:			
Signature:			
Date:			

V6 Series System Commissioning Report – Sheet D

Project name and location		System name		
DSP1 content	Parameters displayed on DSP2	Remarks	Observed values	
			Cooling mode	Heating mode
0.--	Unit address	Master unit: 0; slave units: 1, 2		
1.--	Unit capacity	Refer to Note 1		
2.--	Number of outdoor units	Displayed on master unit PCB only		
3.--	Number of indoor units as set on PCB	Displayed on master unit PCB only		
4.--	Total capacity of outdoor unit	Only available for master unit, displayed on slave units has no sense		
5.--	Total capacity requirement of indoor units	Displayed on master unit PCB only		
6.--	Total corrected capacity requirement of indoor units	Displayed on master unit PCB only		
7.--	Operating mode	Refer to Note 2		
8.--	Outdoor unit actual operating capacity			
9.--	Fan A speed index	Refer to Note 3		
10.--	Fan B speed index	Refer to Note 3		
11.--	Indoor heat exchanger pipe (T2/T2B) temperature (°C)	Actual value = value displayed		
12.--	Main heat exchanger pipe (T3) temperature (°C)	Actual value = value displayed		
13.--	Outdoor ambient (T4) temperature (°C)	Actual value = value displayed		
14.--	Plate heat exchanger cooling refrigerant inlet (T6A) temperature (°C)	Actual value = value displayed		
15.--	Plate heat exchanger cooling refrigerant outlet (T6B) temperature (°C)	Actual value = value displayed		
16.--	Inverter compressor A discharge temperature (°C)	Actual value = value displayed		
17.--	Inverter compressor B discharge temperature (°C)	Actual value = value displayed		
18.--	Inverter module A heatsink temperature (°C)	Actual value = value displayed		
19.--	Inverter module B heatsink temperature (°C)	Actual value = value displayed		
20.--	Plate heat exchanger cooling refrigerant outlet temperature minus inlet temperature (°C)	Actual value = value displayed		
21.--	Discharge superheat degree (°C)	Actual value = value displayed		
22.--	Inverter compressor A current (A)	Actual value = value displayed		
23.--	Inverter compressor B current (A)	Actual value = value displayed		
24.--	EXVA position	Refer to Note 4		
25.--	EXVB position	Refer to Note 4		
26.--	EXVC position	Refer to Note 4		
27.--	Compressor discharge pressure (MPa)	Actual value = value displayed × 0.1		
28.--	Reserved			
29.--	Number of indoor units currently in communication with master unit	Actual value = value displayed		
30.--	Number of indoor units currently operating	Displayed on master unit PCB only		
31.--	Priority mode	Refer to Note 5		
32.--	Silent mode	Refer to Note 6		
33.--	Static pressure mode	Refer to Note 7		
34.--	Reserved			

Part 3 - System Design and Installation
Table continued on next page ...

V6 Series System Commissioning Report – Sheet E

Project name and location	System name
----------------------------------	--------------------

... table continued from previous page

DSP1 content	Parameters displayed on DSP2	Remarks	Observed values	
			Cooling mode	Heating mode
35.--	Reserved			
36.--	DC voltage A	Actual value = value displayed × 10		
37.--	DC voltage B	Actual value = value displayed × 10		
38.--	Reserved			
39.--	Address of VIP indoor unit			
40.--	Reserved			
41.--	Reserved			
42.--	Refrigerant quantity	Refer to Note 8		
43.--	Reserved			
44.--	Power mode	Refer to Note 9		
45.--	Most recent error or protection code	"--" is displayed if no error or protection events have occurred since start-up		
-- --	--	End		

- Notes:
- Outdoor unit capacity setting:
 - 0: 8HP; 1: 10HP; 2: 12HP; 3: 14HP; 4: 16HP; 5: 18HP; 6: 20HP; 7: 22HP; 8: 24HP; 9: 26HP; A: 28HP; B: 30HP; C: 32HP.
 - Operating mode:
 - 0: off; 2: cooling; 3: heating; 4: forced cooling.
 - The fan speed index is related to the fan speed in rpm and can take any integer value in the range 1 (slowest) to 35 (fastest).
 - 480P: steps = value displayed × 4; 3000P: steps = value displayed × 24.
 - Priority mode:
 - 0: auto priority; 1: cooling priority; 2: VIP priority or voting priority; 3: heating only; 4: cooling only.
 - Silent mode:
 - 0: night silent time 6h/10h; 1: night silent time 6h/12h; 2: night silent time 8h/10h; 3: night silent time 8h/12h; 4: no silent mode; 5: silent mode 1; 6: silent mode 2; 7: silent mode 3; 8: super silent mode 1; 9: super silent mode 2; 10: super silent mode 3; 11: super silent mode 4.
 - Static pressure mode:
 - 0: standard static pressure; 1: low static pressure; 2: medium static pressure; 3: high static pressure; 4: super high static pressure.
 - Refrigerant quantity:
 - 0: normal; 1: slightly excessive; 2: significantly excessive; 3: slightly insufficient; 4: significantly insufficient; 5: critically insufficient.
 - Power mode:
 - 0: 100% capacity output; 1: 90% capacity output; 2: 80% capacity output; 3: 70% capacity output; 4: 60% capacity output; 5: 50% capacity output; 6: 40% capacity output; 10: auto power save mode, 100% capacity output; 11: auto power save mode, 90% capacity output; 12: auto power save mode, 80% capacity output; 13: auto power save mode, 70% capacity output; 14: auto power save mode, 60% capacity output; 15: auto power save mode, 50% capacity output; 16: auto power save mode, 40% capacity output;

HVAC & Building Technologies Division
Midea Group

Add.: Midea Headquarters Building, 6 Midea Avenue, Shunde, Foshan, Guangdong, China

Postal code: 528311

cac.midea.com / global.midea.com

Note: Product specifications change from time to time as product improvements and developments are released and may vary from those in this document.

